

**STANDARD DRAWINGS**

**FOR**

**PUBLIC IMPROVEMENTS**

---

*County of San Mateo  
Department Of Public Works*

*555 County Center, 5th Floor  
Redwood City, California 94063-1665  
TEL: (650) 363-4100  
FAX: (650) 361-8220*

*<http://publicworks.smcgov.org>*

# SAN MATEO COUNTY STANDARD DRAWINGS INDEX

---

## COUNTY ROAD STANDARDS

## DRAWING NO.

### -GENERAL ROAD STANDARDS

GENERAL NOTES.....	A
URBAN RESIDENTIAL ONE-WAY LOOP STREET.....	A-1
URBAN CUL DE SAC (R-1 ZONING) URBAN RESIDENTIAL STREET (R-1 ZONING) (MINOR).....	A-2
URBAN RESIDENTIAL COLLECTOR OR MINOR COMMERCIAL STREET (R-2, R-3, P, H-1, O & C-1 ZONING).....	A-3
ARTERIAL, COMMERCIAL & INDUSTRIAL STREET (C-2, M-1 & M-2 ZONING).....	A-4
TWO LEVEL URBAN RESIDENTIAL STREET.....	A-5
RURAL ONE WAY ROAD & LOOP STREET SECTION.....	A-7
CUL DE SAC OR MINOR ROAD - 5 TO 10 PARCELS EACH 5 TO 40 ACRES.....	A-8
CUL DE SAC OR MINOR ROAD - 5 TO 10 PARCELS EACH 20,000 SQ FT TO 5 ACRES.....	A-8
CUL DE SAC OR MINOR ROAD - 5 TO 10 PARCELS EACH 20,000 SQ FT TO 40 ACRES.....	A-9
RURAL COLLECTOR ROAD.....	A-9
RURAL MAJOR COLLECTOR ROAD.....	A-10
PRIVATE ROAD WITHIN MINOR LAND DIVISION (SERVES 2 THRU 4 PARCELS).....	A-11
PRIVATE ROAD WITHIN MINOR LAND DIVISION (SERVES 4 THRU 10 PARCELS AND WITH ALL PARCELS 40 ACRES OR LARGER).....	A-11
RURAL PRIVATE ACCESS ROAD SERVING MINOR DIVISION.... WITHIN 500 FEET OF PUBLIC ROAD.....	A-12
RURAL PRIVATE ACCESS ROAD SERVING MINOR DIVISION MORE THAN 500 FEET FROM A PUBLIC ROAD.....	A-12
URBAN PRIVATE STREET.....	A-13

**COUNTY ROAD STANDARDS**

**DRAWING NO.**

**-ADOPTED ROAD STANDARDS FOR SPECIFIC COMMUNITIES**

**- MIDCOAST AREA -**

MONTARA/MOSS BEACH/SEAL COVE/PRINCETON/MIRAMAR ROAD STANDARDS..... A-6B  
EL GRANADA ROAD STANDARD..... A-6C  
CLIPPER RIDGE ROAD STANDARD..... A-6D

**- SEQUOIA TRACT AREA -**

MAP OF SEQUOIA TRACT ROAD IMPROVEMENT AREA..... A-6E  
SEQUOIA TRACT ROAD STANDARD..... A-6F

**- WEST MENLO PARK AREA -**

MAP OF WEST MENLO PARK ROAD IMPROVEMENT AREA..... A-6G  
WEST MENLO PARK ROAD STANDARD; CONCRETE VALLEY GUTTER..... A-6H

**- MENLO OAKS AREA -**

MAP OF MENLO OAKS ROAD IMPROVEMENT AREA..... A-6J  
MENLO OAKS ROAD STANDARD..... A-6K

**- DEVONSHIRE AREA -**

MAP OF DEVONSHIRE ROAD IMPROVEMENT AREA..... A-6L  
DEVONSHIRE ROAD STANDARD..... A-6M

**STORM DRAINAGE STANDARDS**

**DRAWING NO.**

TYPE GO INLET..... B-1

TYPE GO INLET; APRON DETAILS..... B-1A

TYPE GOL INLET..... B-2

TYPE GOL INLET; APRON DETAILS..... B-2A

STORM DRAINAGE INLETS GENERAL NOTES..... B-3

TYPE 24-10X GRATE..... B-4

TRAFFIC INLET..... B-5

DROP INLET..... B-6

DROP INLET DETAIL (END OPENING: SIDE OPENING)..... B-7

DROP INLET DETAIL (COVER PLATE: ANCHOR BOLT DETAILS)..... B-8

STANDARD STORM DRAIN MANHOLE..... B-10

STANDARD STORM DRAIN MANHOLE (SHALLOW COVER)..... B-11

STORM DRAIN MANHOLE-SHALLOW COVER  
(H≤42", FOR PIPES 42" I.D. OR LESS)..... B-12

STANDARD FLAT TOP STORM DRAIN MANHOLE  
(H≤42", FOR PIPES 42" I.D. OR LESS)..... B-13

STANDARD STORM DRAIN MANHOLE (FOR PIPES I.D. 45" TO 60")..... B-14

STANDARD TRENCH BACKFILL & BEDDING DETAIL FOR STORM DRAIN PIPES... B-15

PIPE CAP DETAIL..... B-16



**SANITARY SEWER STANDARDS**

**DRAWING NO.**

SANITARY SEWER MANHOLE DETAIL..... C-1

SANITARY SEWER MANHOLE COVER, FRAME & STRAP DETAIL;  
SANITARY SEWER FLUSHING INLET COVER..... C-2

TYPICAL CLEANOUT DETAIL; TYPICAL SEWER CLEANOUT BOX..... C-3A

ALTERNATE CLEANOUT DETAIL..... C-3B

SANITARY SEWER FLUSHING INLET DETAIL..... C-4

SEWER LATERAL DETAIL..... C-5

STANDARD TRENCH BACKFILL & BEDDING DETAIL FOR VITRIFIED CLAY &  
DUCTILE IRON SEWER PIPE..... C-6

STANDARD TRENCH BACKFILL & BEDDING FOR PVC SEWER PIPE..... C-7

STANDARD TRENCH BACKFILL & BEDDING DETAILS FOR WEST BAY  
SANITARY SEWER INSTALLATIONS..... C-7.WB

VITRIFIED CLAY, DUCTILE IRON PIPES, & POLYVINYL CHLORIDE PIPE  
LATERAL CONNECTION INSTALLATION DETAIL ON EXISTING PIPE..... C-8

OVERFLOW & BACKFLOW DEVICE DETAIL..... C-9

VITRIFIED CLAY & DUCTILE IRON SEWER PIPE CROSSING REPAIR DETAIL..... C-10

POLYVINYL CHLORIDE (PVC) SEWER PIPE CROSSING REPAIR DETAIL..... C-11

REINFORCED CONCRETE CAP; CONCRETE ENCASEMENT..... C-12

**SAN MATEO COUNTY SEWER AND SANITATION DISTRICTS STANDARD SPECIFICATIONS**

GENERAL NOTES..... C-13

PIPE AND FITTINGS

    -POLYVINYL CHLORIDE PIPE (PVC)..... C-14

    -DUCTILE IRON PIPE (DIP)..... C-14

    -VITRIFIED CLAY PIPE (VCP)..... C-14

TESTING REQUIREMENTS..... C-15

TESTING REQUIREMENTS..... C-16

**STANDARD STRUCTURES**

**DRAWING NO.**

DRIVEWAY WIDTHS & CURB OPENINGS FOR SINGLE FAMILY  
RESIDENTIAL DWELLINGS..... D-1

DRIVEWAY WIDTHS & CURB OPENINGS FOR SINGLE FAMILY  
RESIDENTIAL DWELLINGS..... D-1A

DRIVEWAY WIDTHS & CURB OPENINGS FOR COMMERCIAL AND INDUSTRIAL  
HIGHWAY FRONTAGE..... D-2

DRIVEWAY WIDTHS & CURB OPENINGS FOR COMMERCIAL AND INDUSTRIAL  
HIGHWAY FRONTAGE..... D-2A

CONCRETE CURB, GUTTER & SIDEWALK DETAILS..... D-3

A.C. DIKE AND PATH DETAIL..... D-3A

2' CONCRETE ROLLED CURB & GUTTER..... D-3B

SIDEWALK ACCESS RAMP FOR SIDEWALKS LESS THAN 6' WIDE

    SHEET 1 OF 3..... D-4A

    SHEET 2 OF 3..... D-4B

    SHEET 3 OF 3..... D-4C

VALLEY GUTTER DETAILS..... D-5

DRAINAGE UNDER SIDEWALK..... D-6

DRIVEWAY PLAN AND PROFILE VIEWS..... D-7

STREET NAME SIGN..... D-8

MAILBOX LOCATION & CONSTRUCTION DETAILS..... D-9

MONUMENT, FRAME & COVER..... D-10

**EL GRANADA COMMUNITY PLAN**

    TYPICAL PARKING BAY (P-1)..... D-11

    TYPICAL PARKING BAY (P-1)..... D-12

STANDARD TRENCH BACKFILL AND BEDDING DETAIL FOR GAS, CABLE,  
FIBER OPTICS INSTALLATIONS..... D-13

AC WATER BAR DETAIL..... D-14

**COUNTY LIGHTING STANDARDS**

**DRAWING NO.**

**COUNTY LIGHTING STANDARD**

SHEET 1 OF 4..... E-1A  
SHEET 2 OF 4..... E-1B  
SHEET 3 OF 4..... E-2  
SHEET 4 OF 4..... E-3

**COUNTY WATER STANDARDS**

GENERAL NOTES..... W  
STANDARD SERVICE CONNECTION..... W-1  
STANDARD SERVICE SADDLE REQUIREMENT..... W-2  
STANDARD GATE VALVE ASSEMBLY..... W-3  
STANDARD TAPPING SLEEVE AND VALVE ASSEMBLY..... W-4  
STANDARD FIRE HYDRANT ASSEMBLY..... W-5  
TAPPING SLEEVE, VALVE AND FIRE HYDRANT ASSEMBLY..... W-6  
STANDARD 2” BLOW-OFF ASSEMBLY..... W-7  
DEAD ENDING WATER MAINS..... W-8  
STANDARD FIRE DETECTOR CHECK ASSEMBLY DETAIL..... W-9  
STANDARD TRENCH BACKFILL AND BEDDING DETAIL FOR WATER LINE  
INSTALLATIONS..... W-10  
STANDARD TRENCH BACKFILL AND BEDDING DETAIL FOR REDWOOD CITY  
WATER LINE INSTALLATIONS..... W-10R  
STANDARD WATER MAIN THRUST BLOCK..... W-11  
STANDARD PIPE INSTALLATION DETAILS..... W-12  
STANDARD FABRICATED DOUBLE OFFSET DETAIL..... W-13

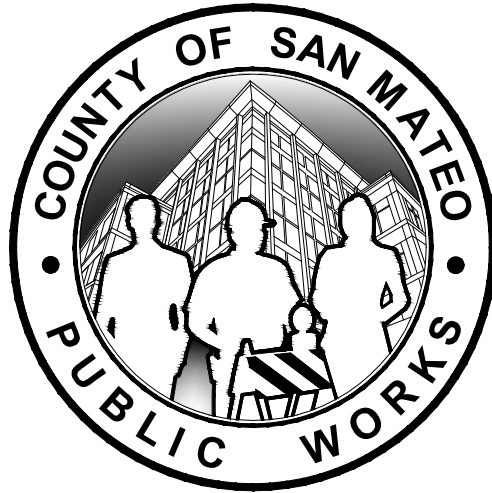

STANDARD DRAWINGS

FOR

PUBLIC IMPROVEMENT

---

**COUNTY  
ROAD  
STANDARDS**

**COUNTY OF SAN MATEO DEPARTMENT  
OF**

DRAWN BY: A.Z.  
CHECKED BY: K.L.  
APPROVED BY: A.M.S.

**PUBLIC WORKS**



REDWOOD CITY  
CALIFORNIA

SCALE: NONE  
DATE: 2-2022  
REVISED: 2-2022

GENERAL NOTES:

1. GENERAL ROAD STANDARDS ARE STANDARDS FOR USE IN AREAS WHERE COMMUNITY ROAD STANDARDS HAVE NOT BEEN ADOPTED. THE PROPOSED USERS OF THESE GENERAL STANDARDS SHOULD CONTACT THE DEPARTMENT OF PUBLIC WORKS PRIOR TO APPLYING THESE STANDARDS.
  
2. GENERAL PURPOSE: THESE STANDARD DRAWINGS ARE INTENDED TO BE USED AS DEPICTED IN THE DESIGN OF CONSTRUCTION PROJECTS LOCATED WITHIN COUNTY OF SAN MATEO RIGHT-OF-WAY AND/OR PROPERTY. THE STANDARD DRAWINGS HAVE BEEN REVIEWED AND STAMPED BY THE DIRECTOR OF PUBLIC WORKS AND HAVE BEEN BACKED BY ENGINEERING ANALYSIS, BUT IT IS THE RESPONSIBILITY OF THE PROJECT'S ENGINEER OF RECORD TO VERIFY THAT THE STANDARD DRAWINGS ARE BEING USED AS ORIGINALLY INTENDED.
  
3. THESE STANDARD DRAWINGS DO NOT INCLUDE DETAILS, SPECIFICATIONS OR GUIDANCE RELATED TO GREEN INFRASTRUCTURE FACILITIES WITHIN THE RIGHT-OF-WAY SUCH AS PERVIOUS PAVEMENT SYSTEMS OR STORMWATER CURB EXTENSIONS. TYPICAL DETAILS FOR GREEN INFRASTRUCTURE FACILITIES AND RELATED COMPONENTS ARE PROVIDED IN A SEPARATE SET OF DETAILS THAT ARE AVAILABLE FROM THE WHERE PUBLIC WORKS STANDARD DRAWINGS MAY REQUIRE MODIFICATION IF THE RIGHT-OF-WAY PROJECT INCLUDES GREEN INFRASTRUCTURE, REFERENCES TO THE TYPICAL GREEN INFRASTRUCTURE DETAILS HAVE BEEN ADDED. IF ADDITIONAL MODIFICATIONS TO STANDARD DRAWINGS ARE NECESSARY TO ACCOMMODATE GREEN INFRASTRUCTURE, APPROVALS OF THESE PROPOSED MODIFICATIONS SHOULD BE REVIEWED BY THE COUNTY ON A PROJECT TO PROJECT BASIS.

COUNTY OF SAN MATEO DEPARTMENT  
OF

PUBLIC WORKS

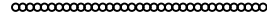

REDWOOD CITY  
CALIFORNIA

DRAWN BY: A.Z.  
CHECKED BY: K.L.  
APPROVED BY: A.M.S.

SCALE: NONE  
DATE: 2-2022  
REVISED: 2-2022

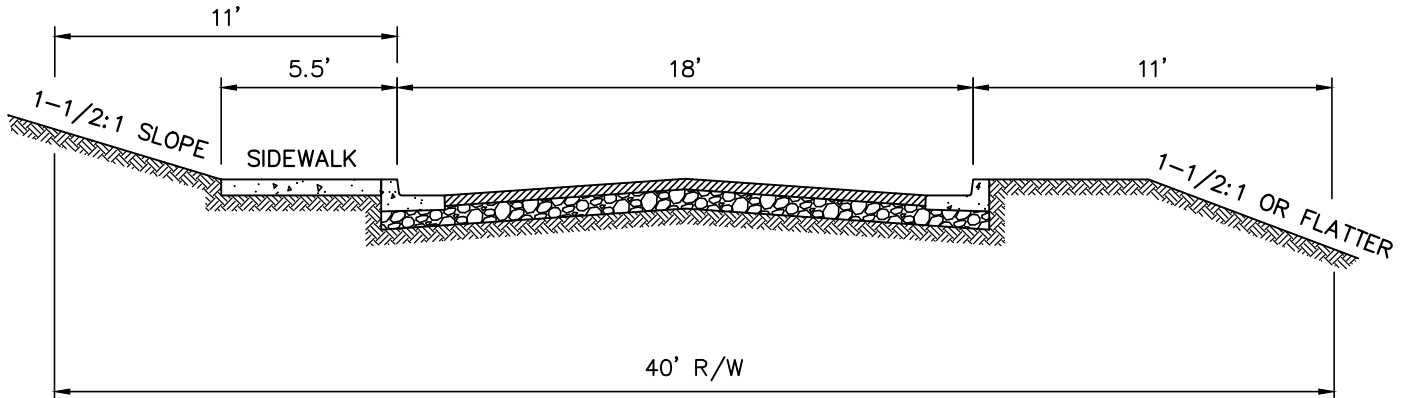

**URBAN RESIDENTIAL ONE-WAY LOOP STREET**  
**(CURBS AND GUTTER-BOTH SIDES, SIDEWALK-ONE SIDE)**

NOTES:

1. CROSS SLOPE SHALL BE 2% CROWNED FROM CENTERLINE, UNLESS DIRECTED OTHERWISE BY DEPARTMENT OF PUBLIC WORKS.
  2. ADD 5' BIKE LANES WHERE REQUIRED BY DEPARTMENT OF PUBLIC WORKS.
  - \* 3. ROADWAY CUT AND FILL SLOPE TO BE DETERMINED BY GEOTECHNICAL ENGINEER.
  4. STRUCTURAL SECTION AS DETERMINED BY THE GEOTECHNICAL ENGINEER AND APPROVED BY THE DEPARTMENT OF PUBLIC WORKS WITH MINIMUM ALLOWABLE SECTION 0.5' CLASS 2 AGGREGATE BASE AND 0.2' ASPHALT CONCRETE.
- \* SEE A-4, NOTE 3.

COUNTY OF SAN MATEO DEPARTMENT  
OF

PUBLIC WORKS

.....  
REDWOOD CITY  
CALIFORNIA

DRAWN BY: A.Z.  
CHECKED BY: K.L.  
APPROVED BY: A.M.S.

SCALE: NONE  
DATE: 2-2022  
REVISED: 2-2022

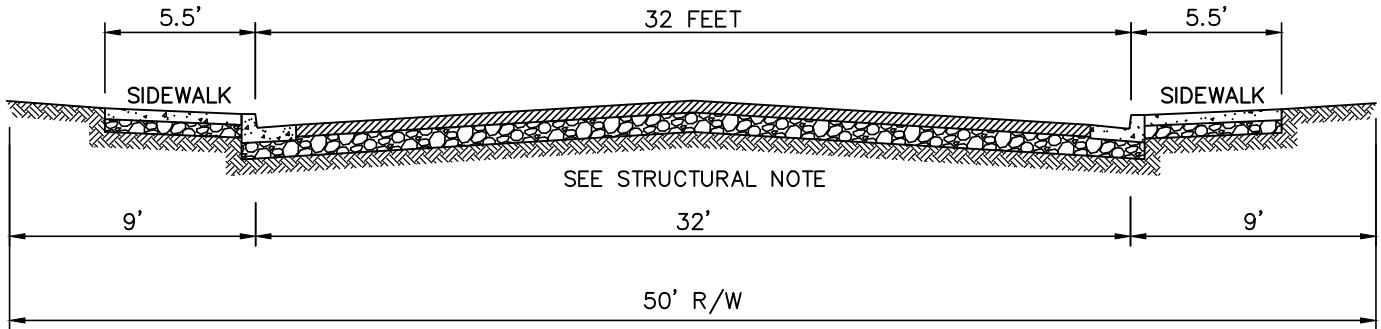

URBAN CUL DE SAC  
(R-1 ZONING)

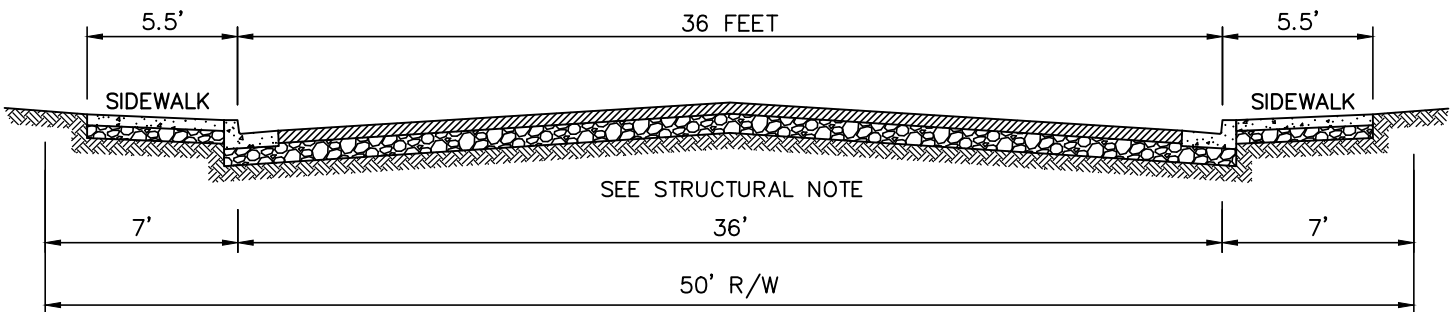

URBAN RESIDENTIAL STREET  
(R-1 ZONING)  
(MINOR)

NOTES:

1. CROSS SLOPE SHALL BE 2% CROWNED FROM CENTERLINE, UNLESS DIRECTED OTHERWISE BY DEPARTMENT OF PUBLIC WORKS.
2. ROADWAY CUT AND FILL SLOPE TO BE DETERMINED BY THE GEOTECHNICAL ENGINEER.
- \* 3. STRUCTURAL SECTION AS DETERMINED BY THE GEOTECHNICAL ENGINEER AND APPROVED BY THE DEPARTMENT OF PUBLIC WORKS WITH MINIMUM ALLOWABLE SECTION 0.5' CLASS 2 AGGREGATE BASE AND 0.2' ASPHALT CONCRETE.

\* SEE A-4, NOTE 3.

COUNTY OF SAN MATEO DEPARTMENT  
OF

PUBLIC WORKS

DRAWN BY: A.Z.  
CHECKED BY: K.L.  
APPROVED BY: A.M.S.

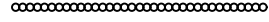

REDWOOD CITY  
CALIFORNIA

SCALE: NONE  
DATE: 2-2022  
REVISED: 2-2022

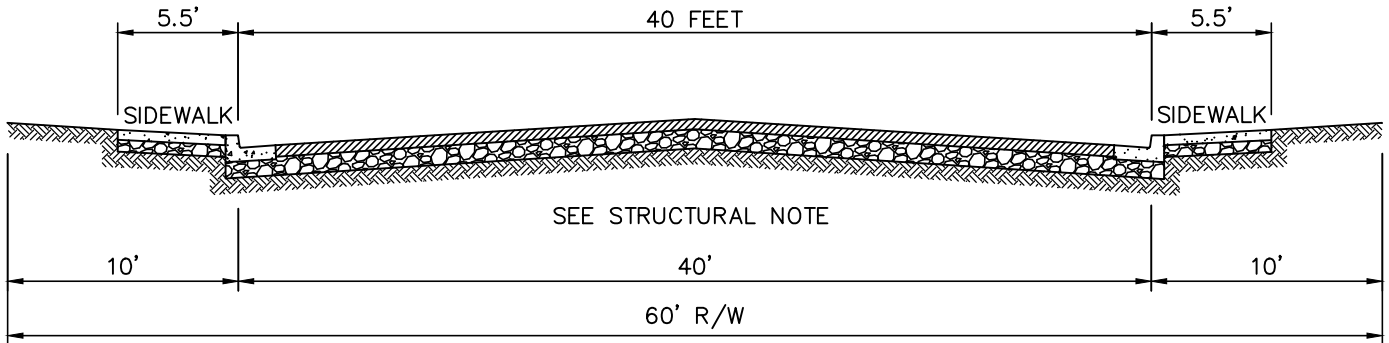

URBAN RESIDENTIAL COLLECTOR  
OR  
MINOR COMMERCIAL STREET

(R-2, R-3, P, H-1, O, & C-1 ZONING)

NOTES:

1. CROSS SLOPE SHALL BE 2% CROWNED FROM CENTERLINE, UNLESS DIRECTED OTHERWISE BY DEPARTMENT OF PUBLIC WORKS.
2. ADD 5' BIKE LANES WHERE REQUIRED BY DEPARTMENT OF PUBLIC WORKS.
- \* 3. ROADWAY CUT AND FILL SLOPE TO BE DETERMINED BY THE GEOTECHNICAL ENGINEER.
4. STRUCTURAL SECTION AS DETERMINED BY THE GEOTECHNICAL ENGINEER AND APPROVED BY THE DEPARTMENT OF PUBLIC WORKS WITH MINIMUM ALLOWABLE SECTION 0.5' CLASS 2 AGGREGATE BASE AND 0.2' ASPHALT CONCRETE.
5. FOR MINOR COMMERCIAL, COMMERCIAL & INDUSTRIAL STREETS – STRUCTURAL SECTION AS DETERMINED BY SOILS ENGINEER AND APPROVED BY DEPARTMENT OF PUBLIC WORKS WITH MINIMUM ALLOWABLE SECTION 0.65' CLASS 2 AGGREGATE BASE & 0.25' ASPHALT CONCRETE.

\* SEE A-4, NOTE 3.



COUNTY OF SAN MATEO DEPARTMENT  
OF

PUBLIC WORKS

REDFORD CITY  
CALIFORNIA

DRAWN BY: A.Z.  
CHECKED BY: K.L.  
APPROVED BY: A.M.S.

SCALE: NONE  
DATE: 2-2022  
REVISED: 2-2022

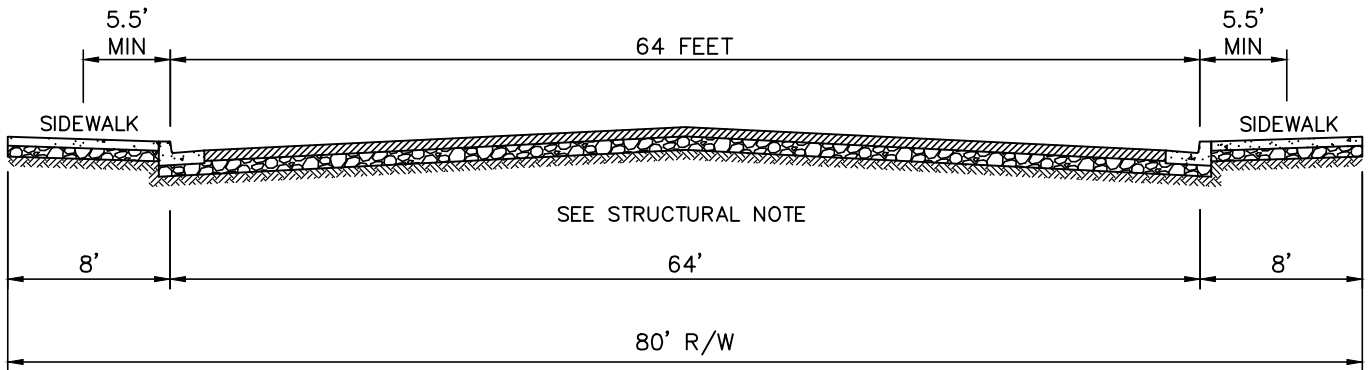

**ARTERIAL, COMMERCIAL AND INDUSTRIAL STREET**

(C-2, M-1, & M-2 ZONING)

NOTES:

1. CROSS SLOPE SHALL BE 2% CROWNED FROM CENTERLINE, UNLESS DIRECTED OTHERWISE BY DEPARTMENT OF PUBLIC WORKS.
2. ADD 5' BIKE LANES WHERE REQUIRED BY DEPARTMENT OF PUBLIC WORKS.
3. ROADWAY CUT AND FILL SLOPE TO BE NO STEEPER THAN 1.5 (HORIZONTAL) TO 1 (VERTICAL) UNLESS OTHERWISE DETERMINED BY GEOTECHNICAL ENGINEER AND APPROVED BY DEPARTMENT OF PUBLIC WORKS.
4. FOR MINOR COMMERCIAL, COMMERCIAL & INDUSTRIAL STREETS – STRUCTURAL SECTION AS DETERMINED BY GEOTECHNICAL ENGINEER AND APPROVED BY DEPARTMENT OF PUBLIC WORKS WITH MINIMUM ALLOWABLE SECTION 0.65' CLASS 2 AGGREGATE BASE & 0.25' ASPHALT CONCRETE.
5. ADD MEDIAN AND OR TURNING LANES (4'-14') WHERE REQUIRED BY DEPARTMENT OF PUBLIC WORKS.

COUNTY OF SAN MATEO DEPARTMENT  
OF

PUBLIC WORKS

.....  
REDWOOD CITY  
CALIFORNIA

DRAWN BY: A.Z.  
CHECKED BY: K.L.  
APPROVED BY: A.M.S.

SCALE: NONE  
DATE: 2-2022  
REVISED: 2-2022

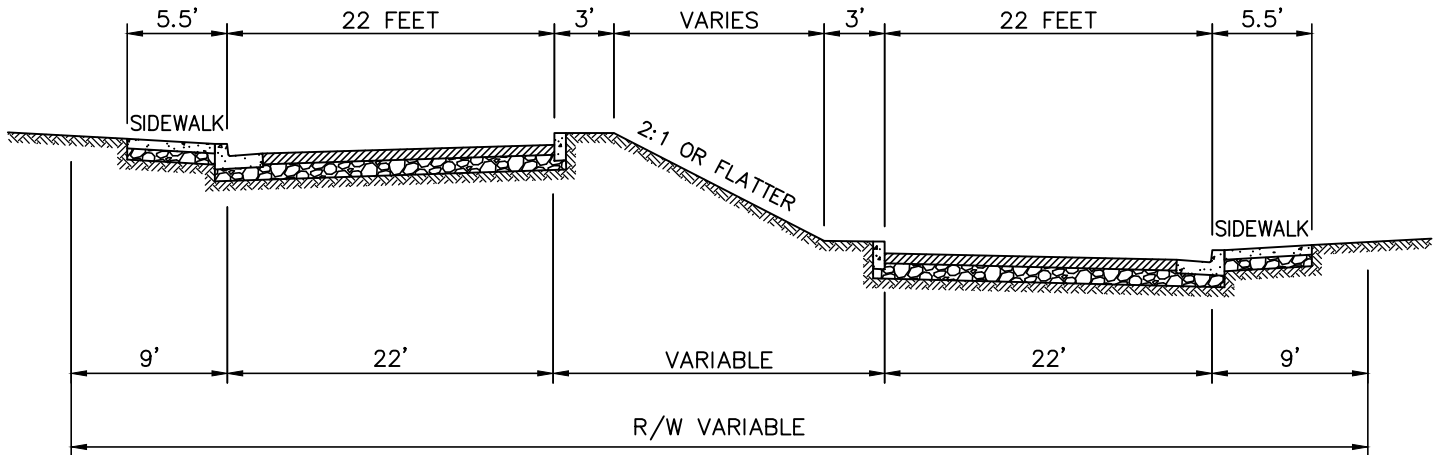

TWO LEVEL URBAN RESIDENTIAL STREET

NOTES:

1. CROSS SLOPE SHALL BE 2% FROM CURB, UNLESS DIRECTED OTHERWISE BY DEPARTMENT OF PUBLIC WORKS.
2. ADD 5' BIKE LANE WHERE REQUIRED BY THE DEPARTMENT OF PUBLIC WORKS.
- \* 3. ROADWAY CUT AND FILL SLOPE TO BE DETERMINED BY GEOTECHNICAL ENGINEER.
4. STRUCTURAL SECTION AS DETERMINED BY GEOTECHNICAL ENGINEER AND APPROVED BY THE DEPARTMENT OF PUBLIC WORKS WITH MINIMUM ALLOWABLE SECTION 0.5' CLASS 2 AGGREGATE BASE AND 0.2' ASPHALT CONCRETE.

\* SEE A-4, NOTE 3.

**COUNTY OF SAN MATEO DEPARTMENT  
OF  
PUBLIC WORKS**

DRAWN BY: A.Z.  
 CHECKED BY: K.L.  
 APPROVED BY: A.M.S.

SCALE: NONE  
 DATE: 2-2022  
 REVISED: 2-2022

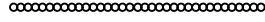

REDWOOD CITY  
CALIFORNIA

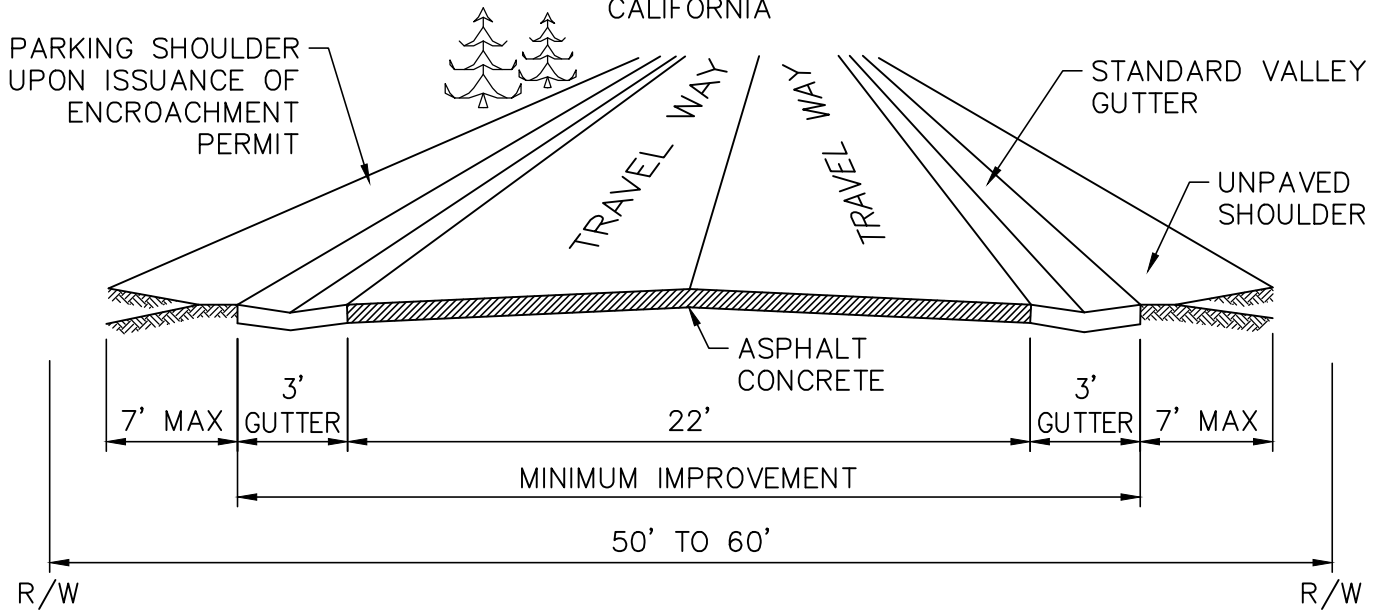

\* PROPERTY OWNERS WILL ONLY BE ISSUED ENCROACHMENT PERMITS FOR PARKING WITHIN THE R/W IN FRONT OF THEIR OWN LOT.

NOTE: OTHER IMPROVEMENTS MAY EXIST THAT WERE CONSTRUCTED PRIOR TO ADOPTION OF SPECIFIC STANDARDS.

**ACCEPTABLE PARKING SURFACE FOR PARKING SHOULDER  
UPON ISSUANCE OF ENCHROACHMENT PERMIT**

MATERIAL \ SLOPE	0-2%	2-7%	7-14%	14%+
UNDISTURBED GROUND	YES*	NO	NO	NO
COMPACTED EARTH	YES*	NO	NO	NO
CEMENTED EARTH	YES	NO	NO	NO
COMPACTED GRAVEL SURFACE	YES	YES	NO	NO
COMPACTED GRAVEL & OIL	YES	YES	YES	NO
ASPHALT	YES	YES	YES	YES

**MONTARA / MOSS BEACH/SEAL COVE/  
PRINCETON/MIRAMAR ROAD STANDARDS**

**COUNTY OF SAN MATEO DEPARTMENT  
OF**

**PUBLIC WORKS**

DRAWN BY: A.Z.  
 CHECKED BY: K.L.  
 APPROVED BY: A.M.S.

SCALE: NONE  
 DATE: 2-2022  
 REVISED: 2-2022

REDWOOD CITY  
 CALIFORNIA

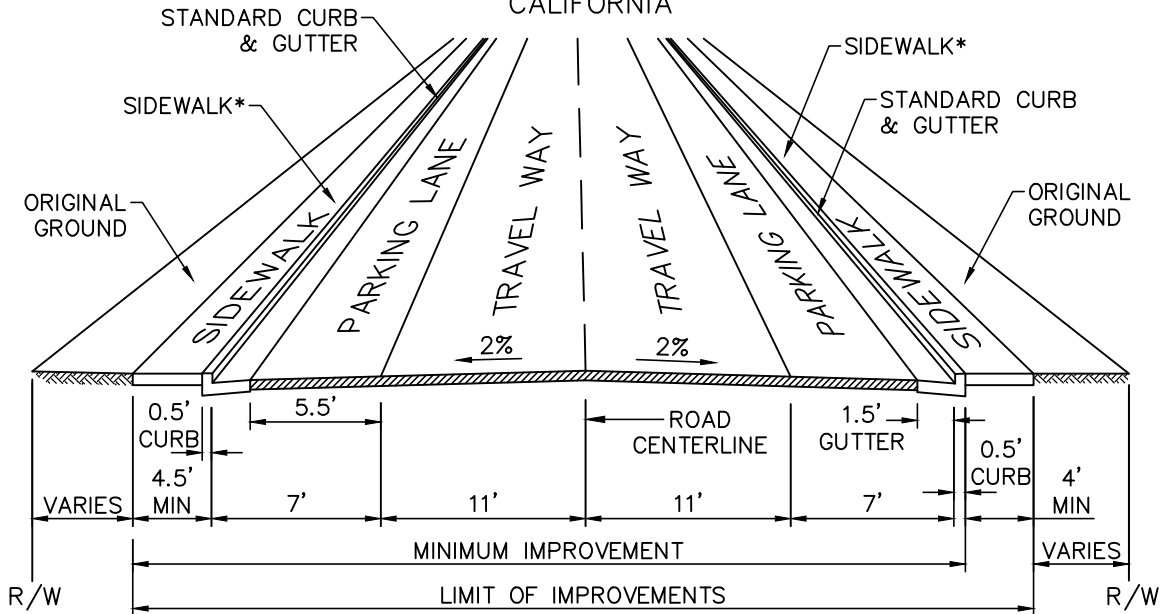

\* SIDEWALKS ON ONE OR BOTH SIDES OF THE STREET,  
 AS DETERMINED BY PROPERTY OWNERS.

**NOTE:** EL GRANADA RESIDENTS CAN ALSO CHOOSE TO USE MONTARA/MOSS BEACH/SEAL COVE/  
 PRINCETON/MIRAMAR STANDARDS ON A PROJECT-BY-PROJECT BASIS.

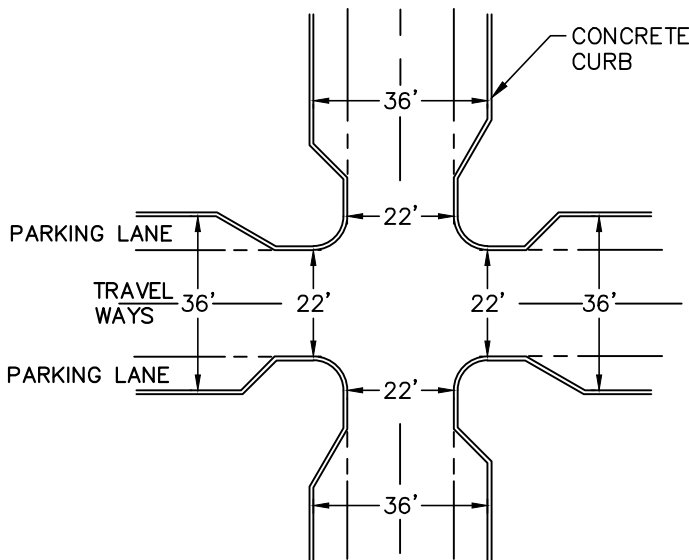

**INTERSECTION DETAIL**

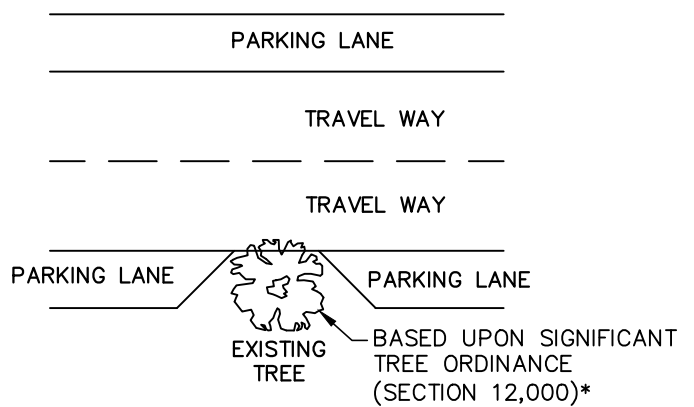

**OBSTRUCTION DETAIL**

\* TREE HAVING MINIMUM 38" CIRCUMFERENCE (12" DIAMETER)  
 MEASURED 4-1/2 FEET ABOVE GROUND

**NOTE:** OTHER IMPROVEMENTS MAY EXIST THAT WERE CONSTRUCTED PRIOR  
 TO ADOPTION OF SPECIFIC STANDARDS.

**EL GRANADA ROAD STANDARD**

COUNTY OF SAN MATEO DEPARTMENT  
OF

PUBLIC WORKS

.....  
REDWOOD CITY  
CALIFORNIA

DRAWN BY: A.Z.  
CHECKED BY: K.L.  
APPROVED BY: A.M.S.

SCALE: NONE  
DATE: 2-2022  
REVISED: 2-2022

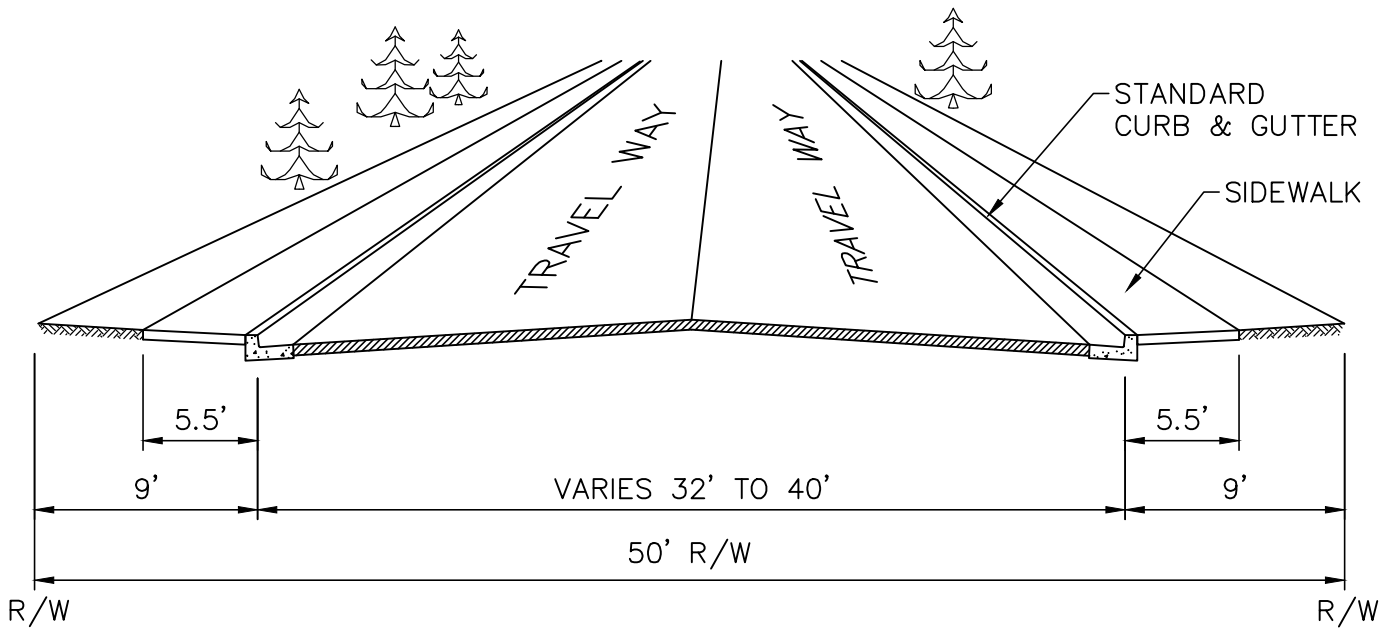

NOTE:

OTHER IMPROVEMENTS MAY EXIST THAT WERE CONSTRUCTED  
PRIOR TO ADOPTION OF SPECIFIC STANDARDS.

CLIPPER RIDGE ROAD STANDARD

COUNTY OF SAN MATEO DEPARTMENT  
OF

PUBLIC WORKS

DRAWN BY: A.Z.  
CHECKED BY: K.L.  
APPROVED BY: A.M.S.

SCALE: NONE  
DATE: 2-2022  
REVISED: 2-2022

REDFORD CITY  
CALIFORNIA

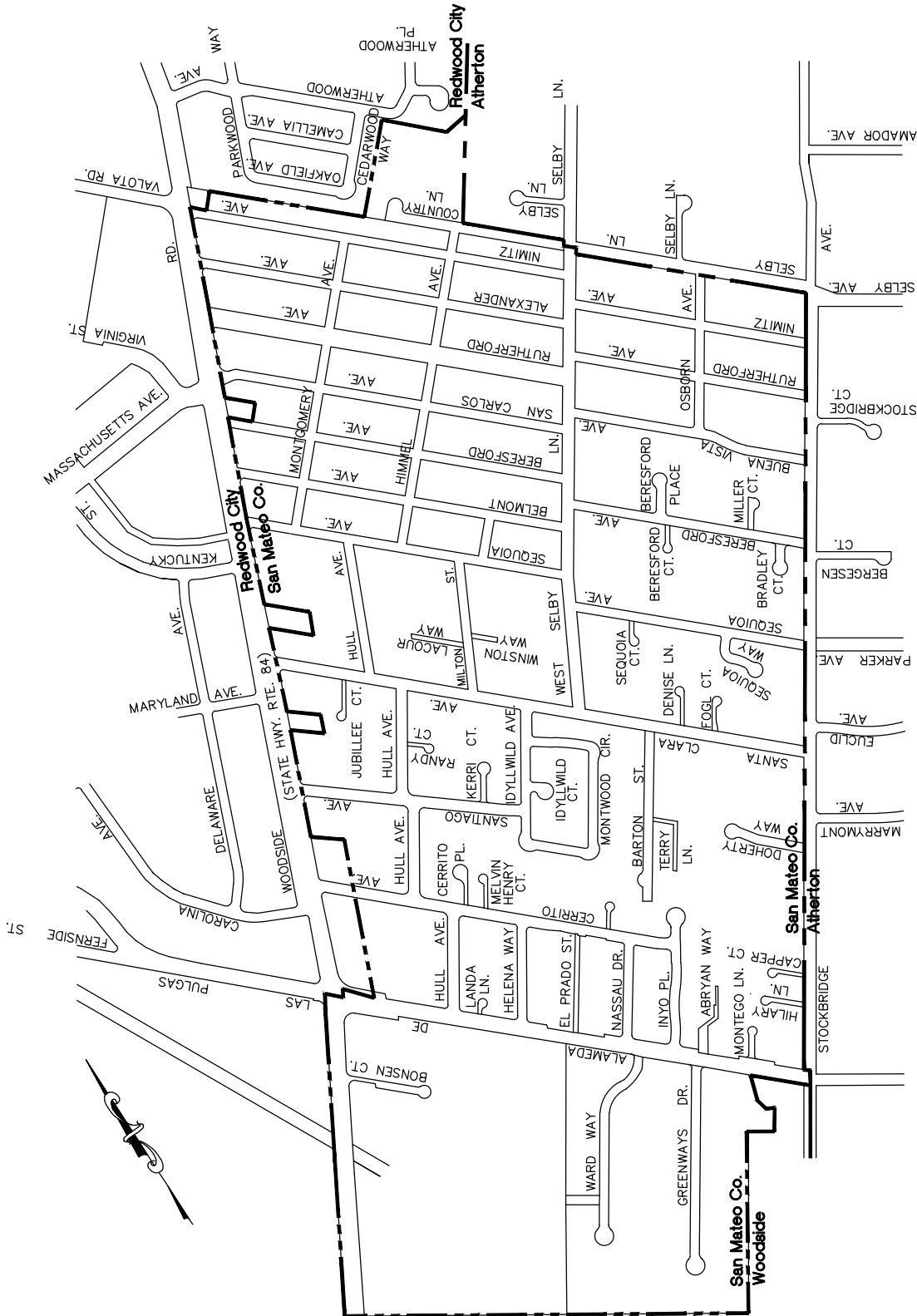

SEQUOIA TRACT ROAD IMPROVEMENT AREA

**COUNTY OF SAN MATEO DEPARTMENT  
OF**

DRAWN BY: A.Z.  
 CHECKED BY: K.L.  
 APPROVED BY: A.M.S.

**PUBLIC WORKS**

.....  
 REDWOOD CITY  
 CALIFORNIA

SCALE: NONE  
 DATE: 2-2022  
 REVISED: 2-2022

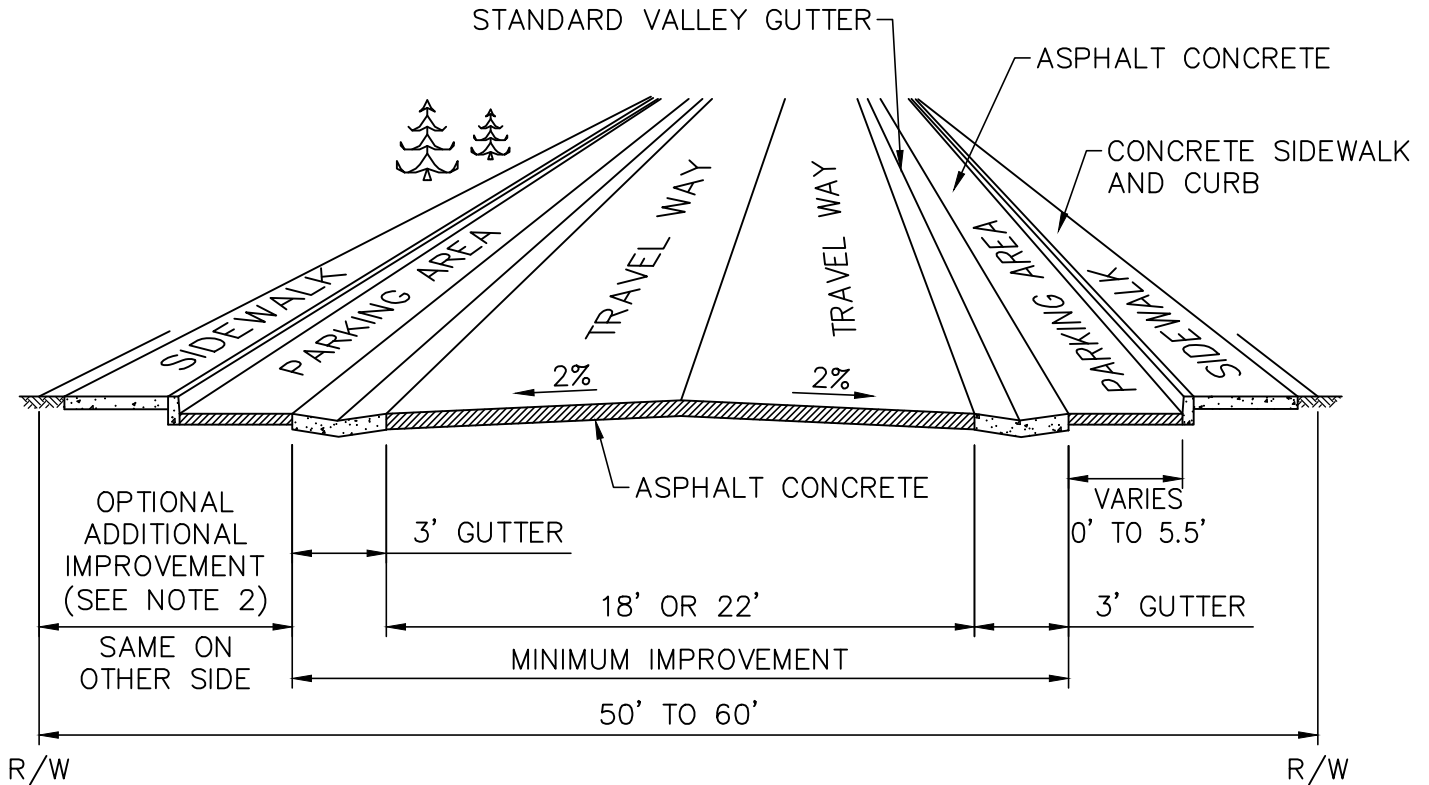

**NOTES:**

1. OTHER IMPROVEMENTS MAY EXIST THAT WERE CONSTRUCTED PRIOR TO ADOPTION OF SPECIFIC STANDARDS.
2. OPTIONAL ADDITIONAL IMPROVEMENTS MAY BE INSTALLED AFTER OBTAINING AN ENCROACHMENT PERMIT. THE COST OF OPTIONAL IMPROVEMENTS WILL BE AT THE SOLE EXPENSE OF APPLICANT.
3. AN 18' OR 22' ROADWAY IMPROVEMENT MAY BE BUILT, DEPENDING ON RESULTS OF A SURVEY OF THE PROPERTY OWNERS CONDUCTED BY THE PUBLIC WORKS DEPARTMENT.

**SEQUOIA TRACT ROAD STANDARD**

# COUNTY OF SAN MATEO DEPARTMENT OF PUBLIC WORKS

DRAWN BY: A.Z.  
CHECKED BY: K.L.  
APPROVED BY: A.M.S.

SCALE: NONE  
DATE: 2-2022  
REVISED: 2-2022

REDWOOD CITY  
CALIFORNIA

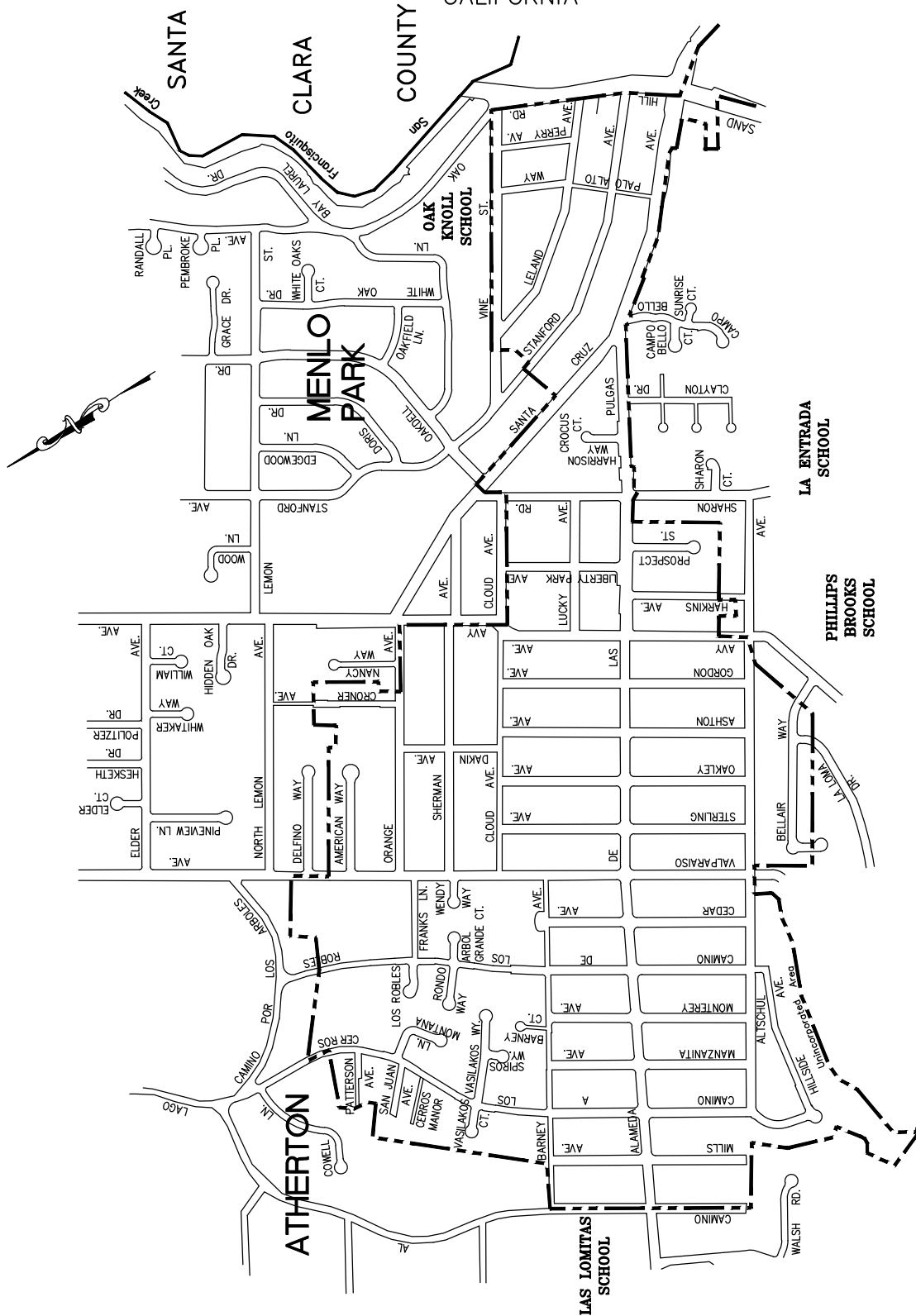

**WEST MENLO PARK ROAD IMPROVEMENT AREA**



**COUNTY OF SAN MATEO DEPARTMENT  
OF**

DRAWN BY: A.Z.  
 CHECKED BY: K.L.  
 APPROVED BY: A.M.S.

**PUBLIC WORKS**



REDWOOD CITY  
CALIFORNIA

SCALE: NONE  
 DATE: 2-2022  
 REVISED: 2-2022

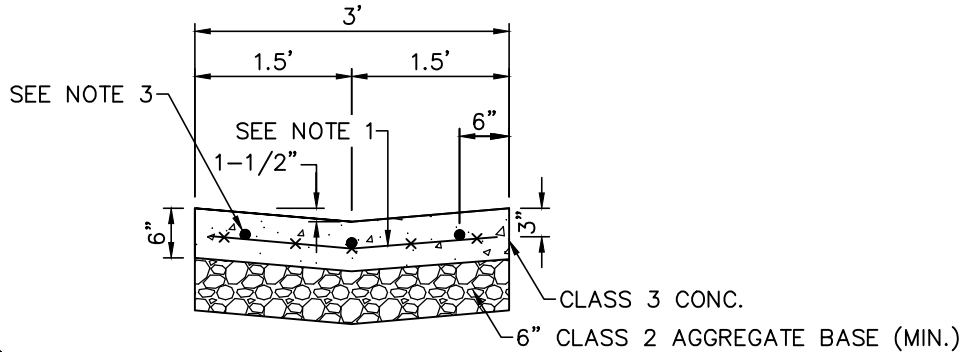

**NOTES:**

1. REINFORCEMENT SHALL CONSIST OF 6" x 6" - #10/#10 WELDED WIRE FABRIC.
2. CONCRETE VALLEY GUTTER SHALL BE INSTALLED PRIOR TO PAVING, UNLESS ENGINEER APPROVES OTHERWISE.
3. PLACE 1/2" DIAMETER x 18" LONG DOWELS, AT EXPANSION JOINTS, AS SHOWN.
4. PLACE 1/4" THICK EXPANSION JOINTS FULL WIDTH 20' ON CENTER.
5. SUB-BASE MATERIALS WITHIN 30" OF SUBGRADE SHALL BE COMPACTED TO 95% R.C.
6. PLACE 1/4" DEEP SCORE FULL WIDTH 20' ON CENTER, BETWEEN EXPANSION JOINTS.

**CONCRETE VALLEY GUTTER**

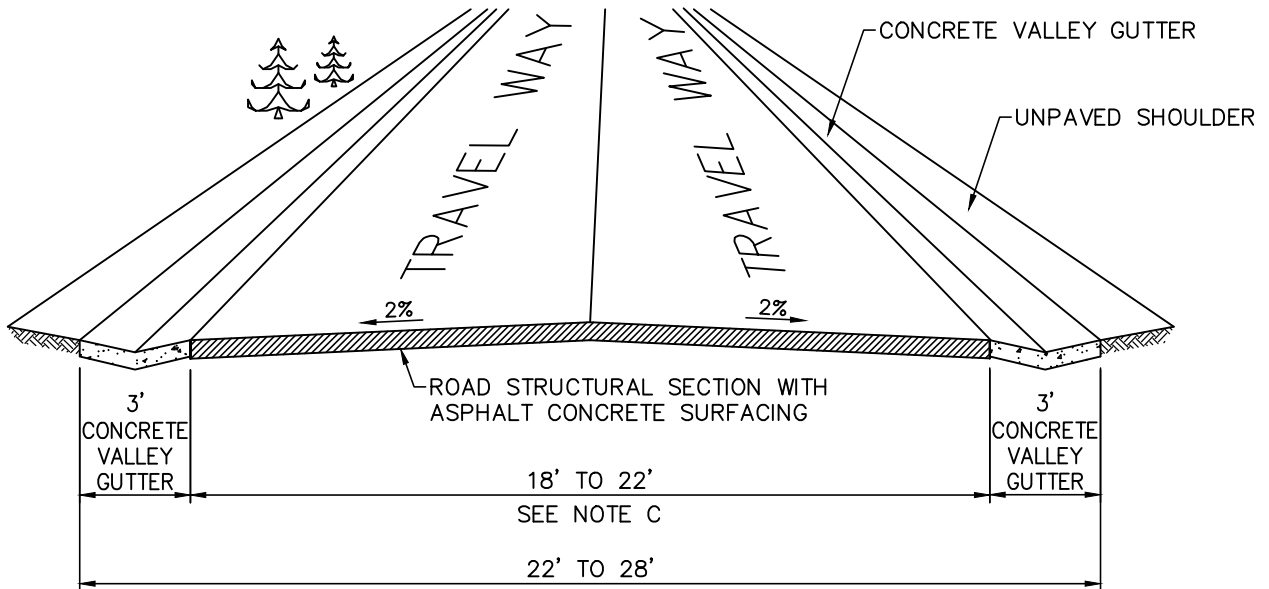

**NOTES:**

- A. OTHER IMPROVEMENTS MAY EXIST THAT WERE CONSTRUCTED PRIOR TO ADOPTION OF SPECIFIC STANDARDS.
- B. OPTIONAL ADDITIONAL IMPROVEMENTS MAY BE INSTALLED AFTER OBTAINING AN ENCROACHMENT PERMIT. THE COST OF OPTIONAL IMPROVEMENTS WILL BE AT THE SOLE EXPENSE OF APPLICANT.
- C. AN 18' OR 22' ROADWAY IMPROVEMENT MAY BE BUILT, DEPENDING ON RESULTS OF A SURVEY OF THE PROPERTY OWNERS CONDUCTED BY THE PUBLIC WORKS DEPARTMENT.

**WEST MENLO PARK ROAD STANDARD**

A-6H

ADOPTED: JAN. 2003

COUNTY OF SAN MATEO DEPARTMENT  
OF  
PUBLIC WORKS

DRAWN BY: A.Z.  
CHECKED BY: K.L.  
APPROVED BY: A.M.S.

SCALE: NONE  
DATE: 2-2022  
REVISED: 2-2022

.....  
REDWOOD CITY  
CALIFORNIA

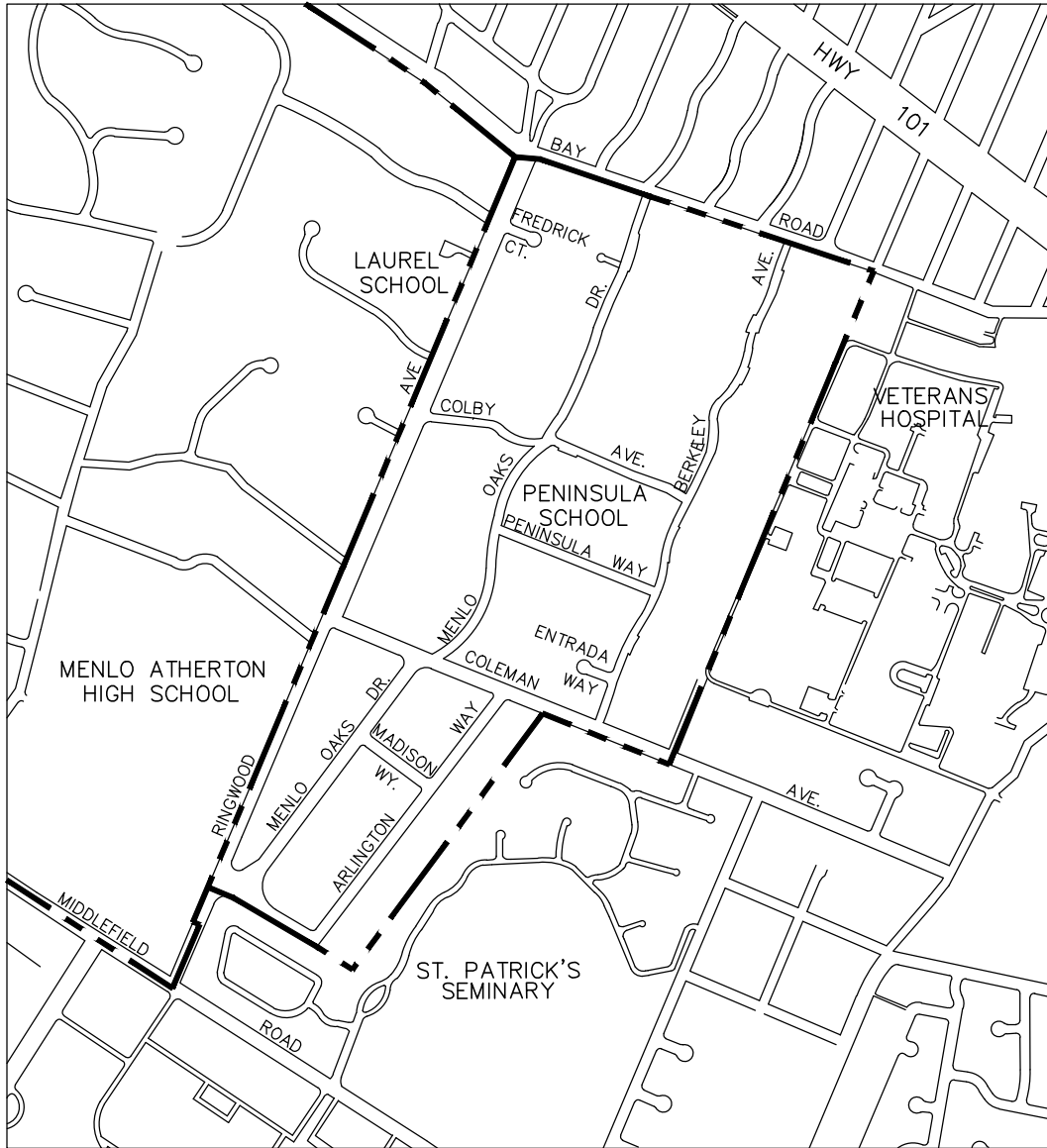

**MENLO OAKS ROAD IMPROVEMENT AREA**

COUNTY OF SAN MATEO DEPARTMENT  
OF

PUBLIC WORKS

.....  
REDWOOD CITY  
CALIFORNIA

DRAWN BY: A.Z.  
CHECKED BY: K.L.  
APPROVED BY: A.M.S.

SCALE: NONE  
DATE: 2-2022  
REVISED: 2-2022

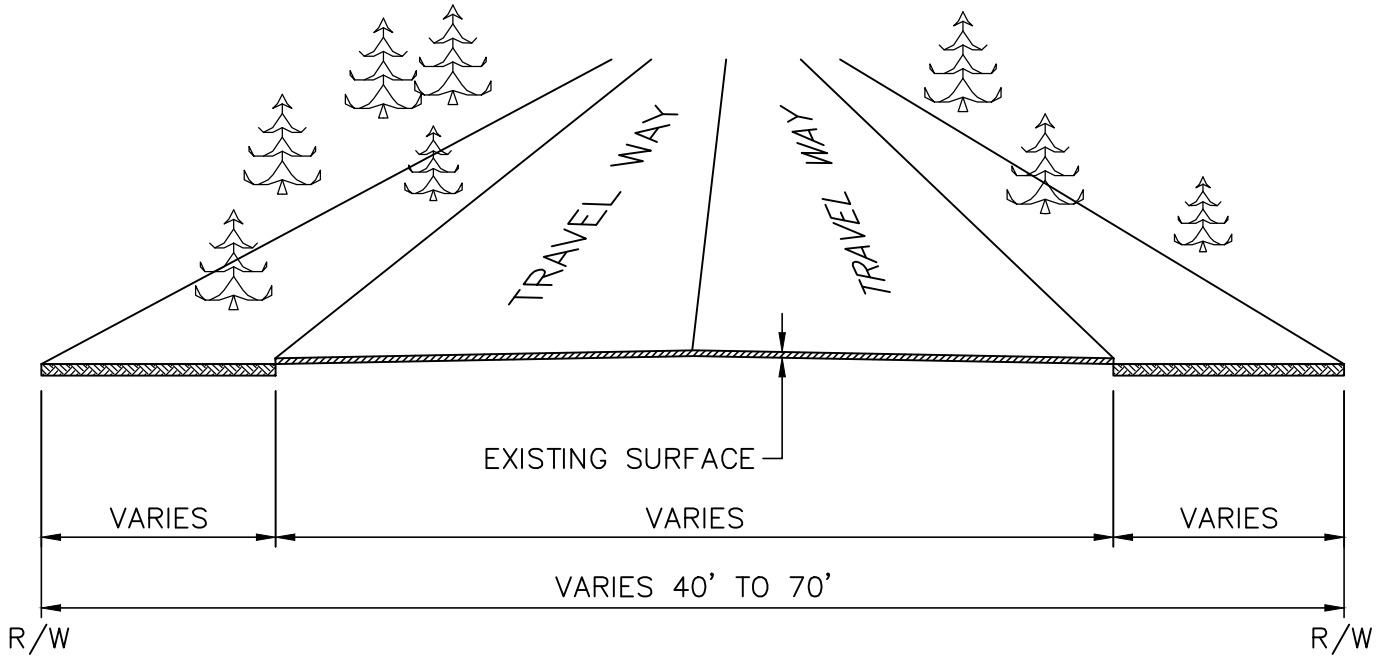

1. ON APRIL 28, 1998, THE BOARD OF SUPERVISORS ADOPTED RESOLUTION NUMBER 61884 ADOPTING THE CURRENT WIDTH OF THE EXISTING ROADS AS THE STANDARD FOR THE MENLO OAKS AREA AND DETERMINING THAT FUTURE IMPROVEMENTS WILL CONSIST SOLELY OF MAINTAINING THE EXISTING ROADS.
2. A FEW ROADS HAVE OTHER IMPROVEMENTS, SUCH AS CURB & GUTTER, THAT WERE CONSTRUCTED PRIOR TO ADOPTION OF THIS STANDARD.

MENLO OAKS ROAD STANDARD

COUNTY OF SAN MATEO DEPARTMENT  
OF  
PUBLIC WORKS

DRAWN BY: A.Z.  
CHECKED BY: K.L.  
APPROVED BY: A.M.S.

SCALE: NONE  
DATE: 2-2022  
REVISED: 2-2022

REDFORD CITY  
CALIFORNIA

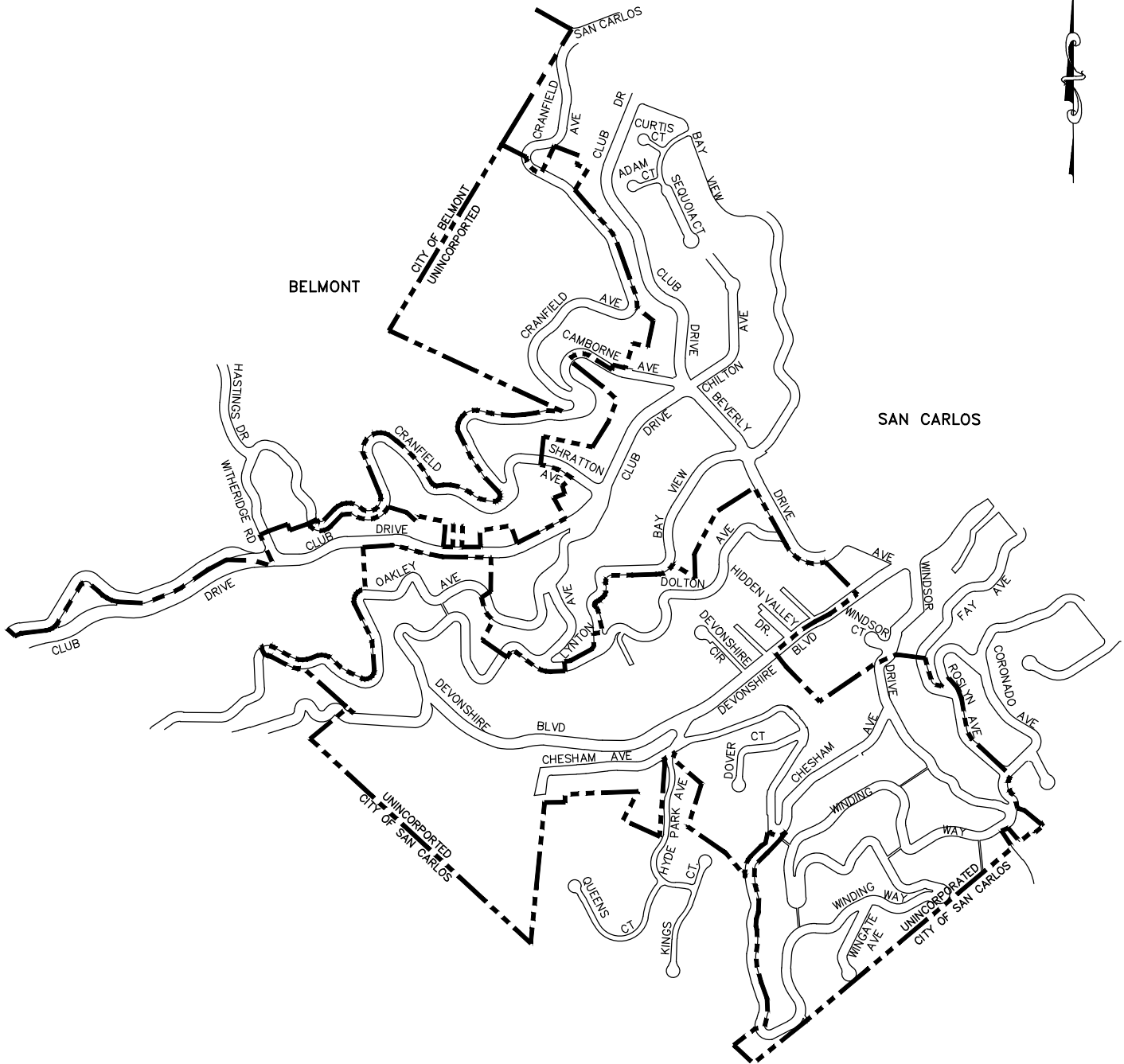

DEVONSHIRE ROAD IMPROVEMENT AREA

COUNTY OF SAN MATEO DEPARTMENT  
OF

PUBLIC WORKS

.....  
REDWOOD CITY  
CALIFORNIA

DRAWN BY: A.Z.  
CHECKED BY: K.L.  
APPROVED BY: A.M.S.

SCALE: NONE  
DATE: 2-2022  
REVISED: 2-2022

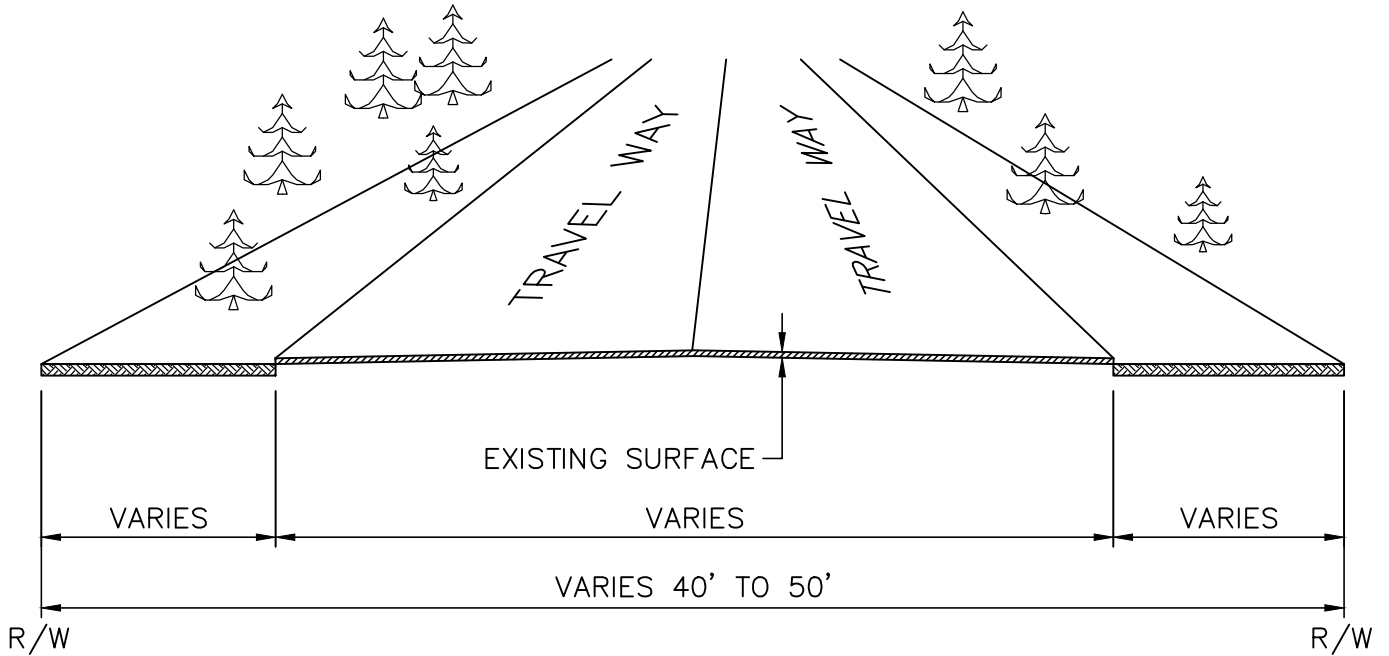

NOTES:

1. ON FEBRUARY 8, 2000, THE BOARD OF SUPERVISORS ADOPTED RESOLUTION NUMBER 63403 ADOPTING THE CURRENT WIDTH OF THE EXISTING ROADS AS THE STANDARD FOR THE DEVONSHIRE AREA AND DETERMINING THAT FUTURE IMPROVEMENTS WILL CONSIST SOLELY OF MAINTAINING THE EXISTING ROADS.
2. A FEW ROADS HAVE OTHER IMPROVEMENTS, SUCH AS CURB & GUTTER, THAT WERE CONSTRUCTED PRIOR TO ADOPTION OF THIS STANDARD.

DEVONSHIRE ROAD STANDARD

COUNTY OF SAN MATEO DEPARTMENT  
OF

PUBLIC WORKS

REDFORD CITY  
CALIFORNIA

DRAWN BY: A.Z.  
CHECKED BY: K.L.  
APPROVED BY: A.M.S.

SCALE: NONE  
DATE: 2-2022  
REVISED: 2-2022

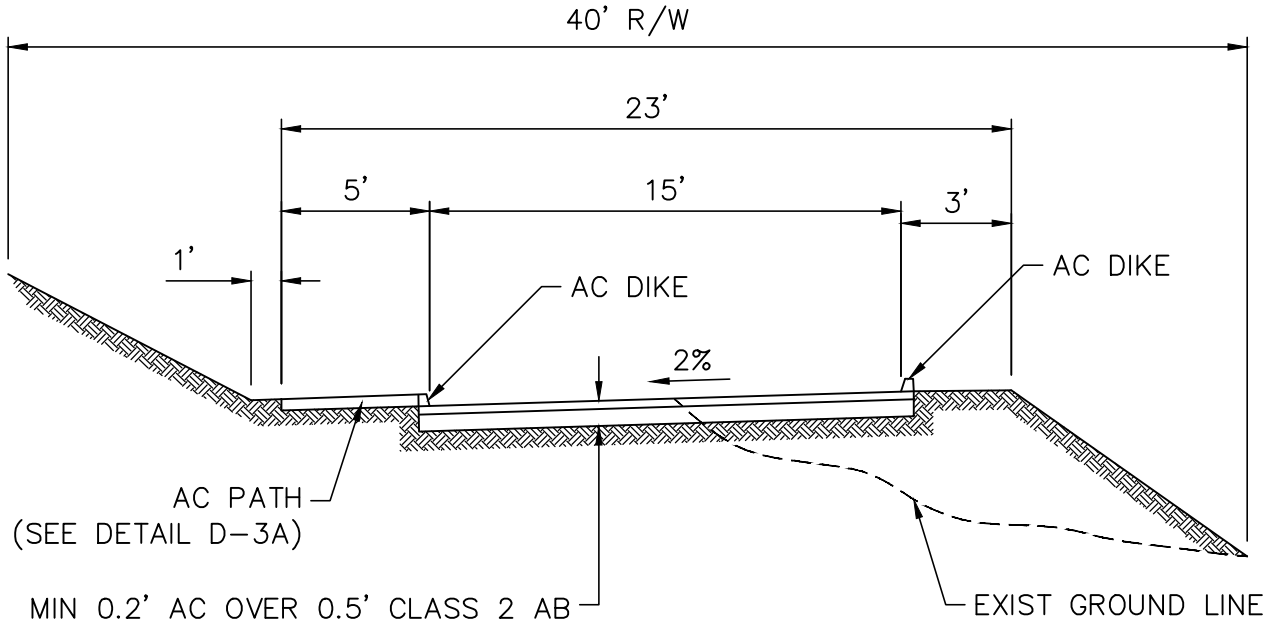

RURAL ONE WAY ROAD  
AND LOOP STREET SECTION

NOTES:

1. CROSS SLOPE SHALL BE 2% FROM FACE OF BERM UNLESS DIRECTED OTHERWISE BY DIRECTOR OF PUBLIC WORKS.
- \* 2. ROADWAY CUT AND FILL SLOPE TO BE DETERMINED BY SOILS ENGINEER.
3. STRUCTURAL SECTION AS DETERMINED BY THE SOILS ENGINEER AND APPROVED BY THE DIRECTOR OF PUBLIC WORKS WITH MINIMUM ALLOWABLE SECTION 0.5' CLASS 2 AGGREGATE BASE & 0.2' ASPHALT CONCRETE.
- \* SEE A-4, NOTE 3.

**COUNTY OF SAN MATEO DEPARTMENT  
OF**

DRAWN BY: A.Z.  
 CHECKED BY: K.L.  
 APPROVED BY: A.M.S.

**PUBLIC WORKS**

.....  
 REDWOOD CITY  
 CALIFORNIA

SCALE: NONE  
 DATE: 2-2022  
 REVISED: 2-2022

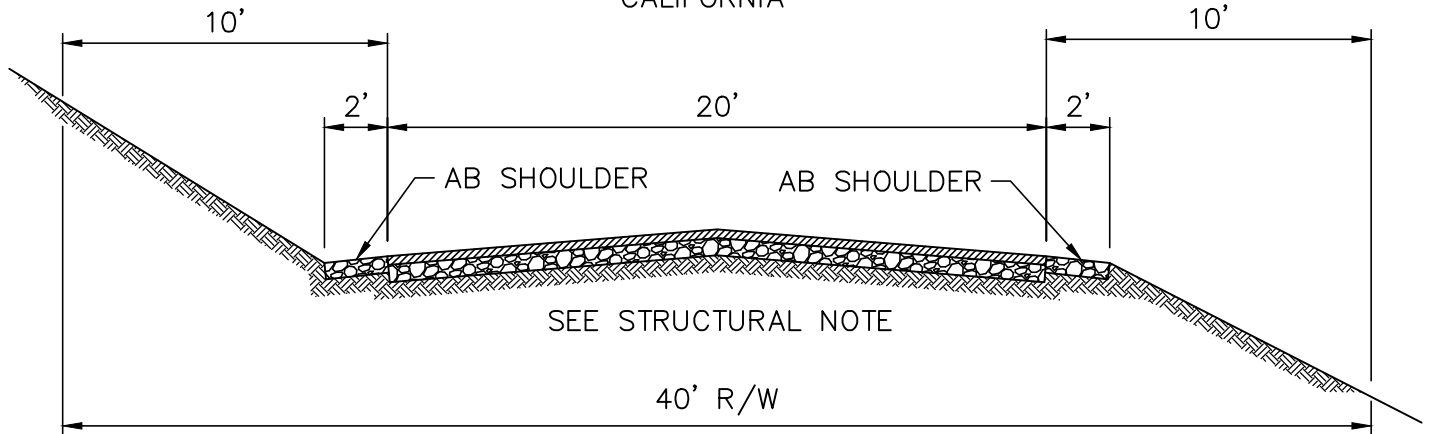

**CUL-DE-SAC OR MINOR ROAD - 5 TO 10 PARCELS**  
**EACH 5 TO 40 ACRES**

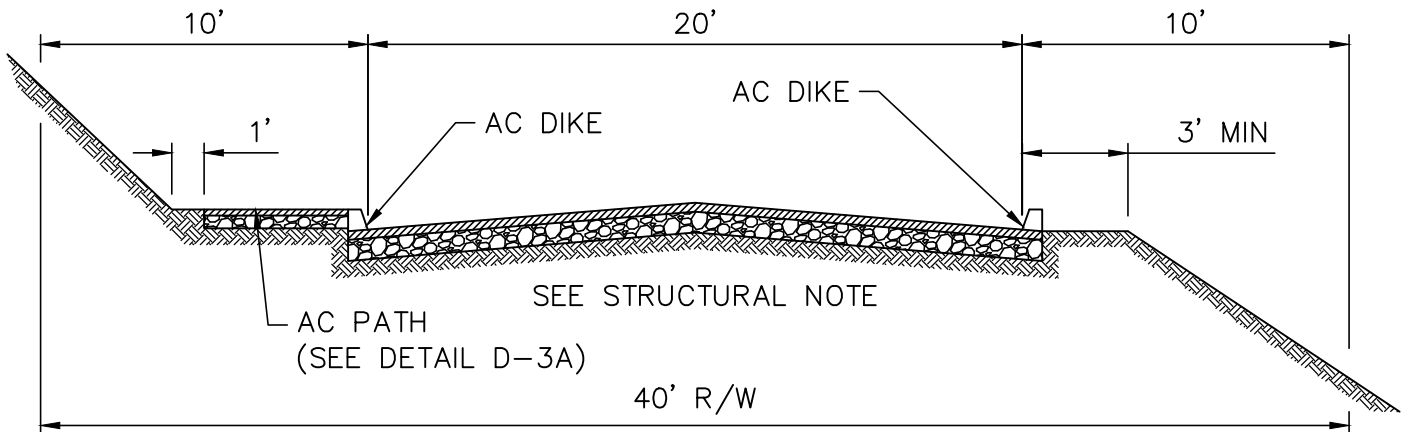

**CUL-DE-SAC OR MINOR ROAD - 5 TO 10 PARCELS**  
**EACH 20,000 SQ. FT. TO 5 ACRES**

**NOTES:**

1. CROSS SLOPE SHALL BE 2% CROWNED FROM CENTERLINE, UNLESS DIRECTED OTHERWISE BY DEPARTMENT OF PUBLIC WORKS.
  - \* 2. ROADWAY CUT AND FILL SLOPE TO BE DETERMINED BY GEOTECHNICAL ENGINEER.
  3. ADD 5' BIKE LANE WHERE REQUIRED BY THE DEPARTMENT OF PUBLIC WORKS.
  4. STRUCTURAL SECTION AS DETERMINED BY GEOTECHNICAL ENGINEER AND APPROVED BY THE DEPARTMENT OF PUBLIC WORKS WITH MINIMUM REQUIRED SECTION 0.5' CLASS 2 AGGREGATE BASE AND 0.2' ASPHALT CONCRETE.
- \* SEE A-4, NOTE 3.

**COUNTY OF SAN MATEO DEPARTMENT  
OF**

DRAWN BY: A.Z.  
 CHECKED BY: K.L.  
 APPROVED BY: A.M.S.

**PUBLIC WORKS**

.....  
 REDWOOD CITY  
 CALIFORNIA

SCALE: NONE  
 DATE: 2-2022  
 REVISED: 2-2022

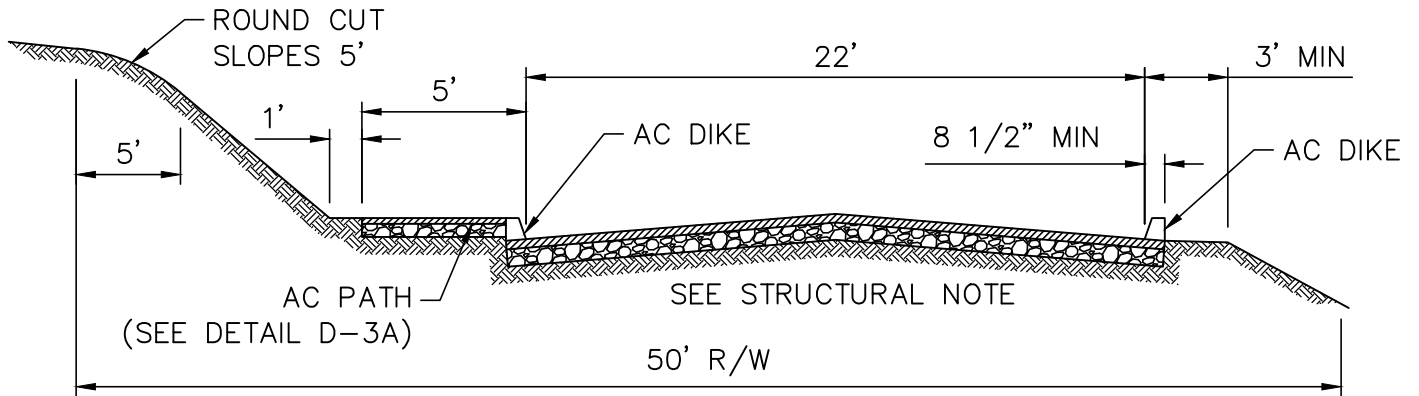

**RURAL CUL-DE-SAC OR MINOR ROAD MORE THAN  
10 PARCELS EACH 20,000 SQ. FT. TO 40 ACRES**

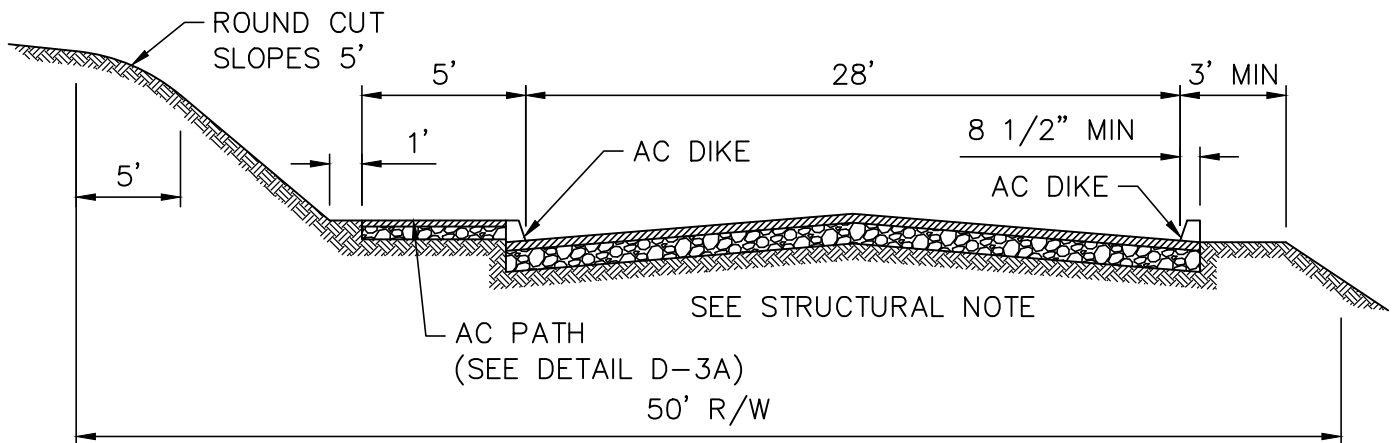

**RURAL COLLECTOR ROAD**

**NOTES:**

1. CROSS SLOPE SHALL BE 2% CROWNED FROM CENTERLINE, UNLESS DIRECTED OTHERWISE BY DEPARTMENT OF PUBLIC WORKS.
  - \* 2. ROADWAY CUT AND FILL SLOPE TO BE DETERMINED BY GEOTECHNICAL ENGINEER.
  3. ADD 5' BIKE LANE WHERE REQUIRED BY THE DEPARTMENT OF PUBLIC WORKS.
  4. STRUCTURAL SECTION AS DETERMINED BY GEOTECHNICAL ENGINEER AND APPROVED BY THE DEPARTMENT OF PUBLIC WORKS WITH MINIMUM REQUIRED SECTION 0.5' CLASS 2 AGGREGATE BASE AND 0.2' ASPHALT CONCRETE.
- \* SEE A-4, NOTE 3.



COUNTY OF SAN MATEO DEPARTMENT  
OF

PUBLIC WORKS

.....  
REDWOOD CITY  
CALIFORNIA

DRAWN BY: A.Z.  
CHECKED BY: K.L.  
APPROVED BY: A.M.S.

SCALE: NONE  
DATE: 2-2022  
REVISED: 2-2022

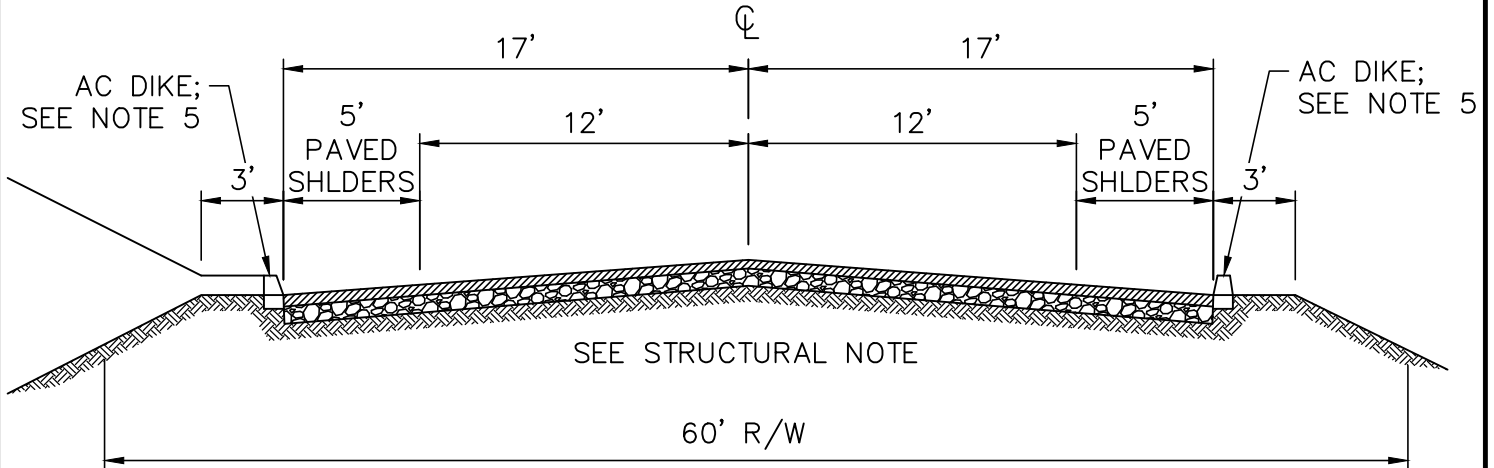

RURAL MAJOR COLLECTOR ROAD

NOTES:

1. CROSS SLOPE SHALL BE 2% CROWNED FROM CENTERLINE, UNLESS DIRECTED OTHERWISE BY DEPARTMENT OF PUBLIC WORKS.
  2. ADD 5' BIKE LANE WHERE REQUIRED BY THE DEPARTMENT OF PUBLIC WORKS.
  - \* 3. ROADWAY CUT AND FILL SLOPE TO BE DETERMINED BY GEOTECHNICAL ENGINEER.
  4. STRUCTURAL SECTION AS DETERMINED BY GEOTECHNICAL ENGINEER AND APPROVED BY THE DEPARTMENT OF PUBLIC WORKS WITH MINIMUM REQUIRED SECTION 0.5' CLASS 2 AGGREGATE BASE AND 0.2' ASPHALT CONCRETE.
  5. CONSTRUCT AC DIKE WHERE SHOWN ON PLANS OR AS DIRECTED BY THE ENGINEER.
- \* SEE A-4, NOTE 3.

COUNTY OF SAN MATEO DEPARTMENT  
OF

PUBLIC WORKS

REDFORD CITY  
CALIFORNIA

DRAWN BY: A.Z.  
CHECKED BY: K.L.  
APPROVED BY: A.M.S.

SCALE: NONE  
DATE: 2-2022  
REVISED: 2-2022

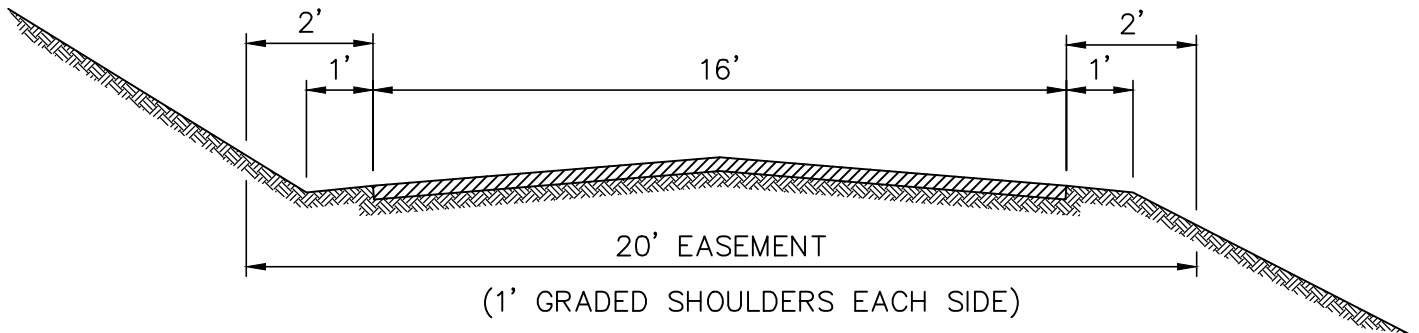

PRIVATE ROAD WITHIN MINOR LAND DIVISION  
SERVES 2 THRU 4 PARCELS

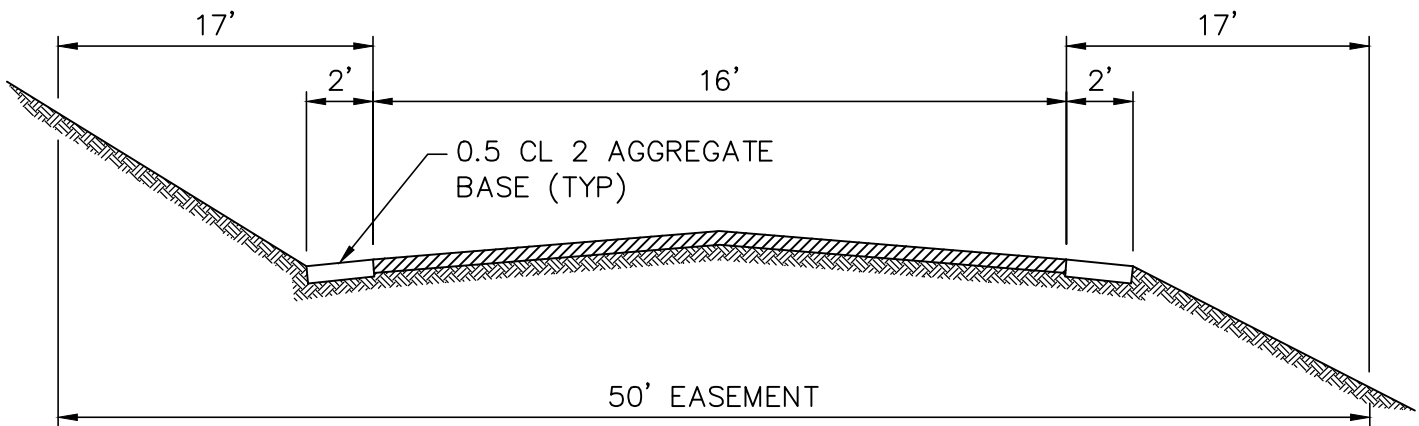

PRIVATE ROAD WITHIN MINOR LAND DIVISION  
SERVES 4 THRU 10 PARCELS AND WITH ALL  
PARCELS 40 ACRES OR LARGER

NOTES:

1. PRIVATE ROAD TO BE USED ON MINOR SUBDIVISIONS ONLY AND SHALL BE SURFACED WITH 0.5' CLASS 2 AGGREGATE BASE ROCK OR EQUIVALENT, COMPACTED TO 95% WITH A PENETRATION COAT OF LIQUID ASPHALT.
  2. PRIVATE ROAD STANDARDS MAY BE UTILIZED ON RURAL MINOR SUBDIVISION CONTAINING 10 OR LESS PARCELS.
  3. CROSS SLOPE SHALL BE 2% CROWNED FROM CENTERLINE, UNLESS DIRECTED OTHERWISE BY DEPARTMENT OF PUBLIC WORKS.
  - \* 4. ROADWAY CUT AND FILL SLOPE TO BE DETERMINED BY GEOTECHNICAL ENGINEER.
- \* SEE A-4, NOTE 3.

COUNTY OF SAN MATEO DEPARTMENT  
OF

PUBLIC WORKS

REDFORD CITY  
CALIFORNIA

DRAWN BY: A.Z.  
CHECKED BY: K.L.  
APPROVED BY: A.M.S.

SCALE: NONE  
DATE: 2-2022  
REVISED: 2-2022

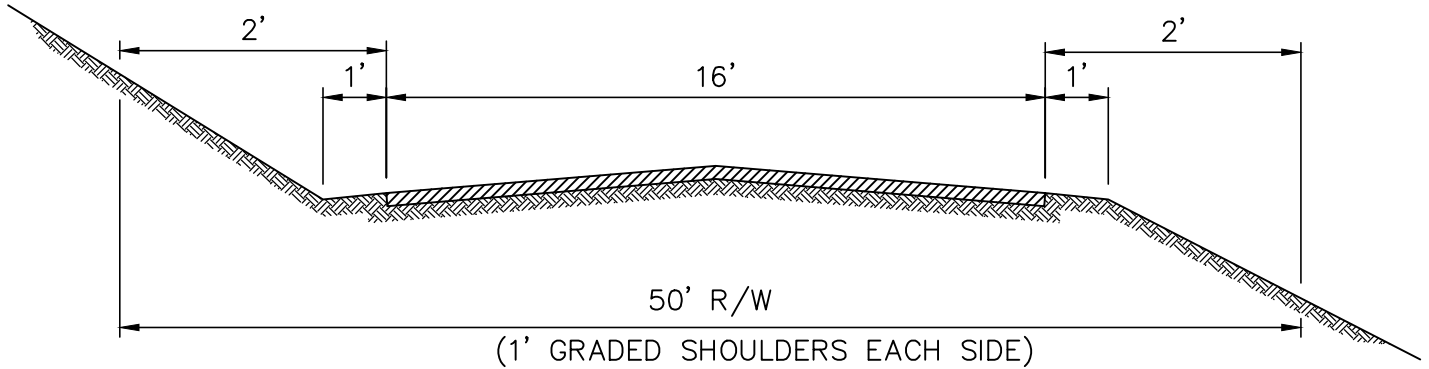

**RURAL PRIVATE ACCESS ROAD SERVING MINOR DIVISION  
WITHIN 500 FEET OF PUBLIC ROAD**

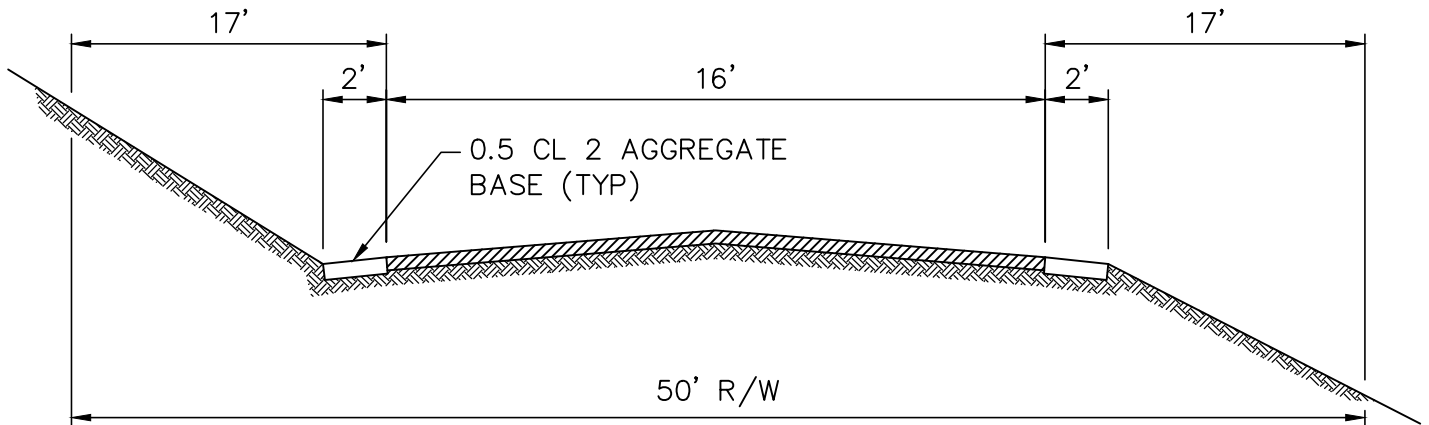

**RURAL PRIVATE ACCESS ROAD SERVING MINOR  
DIVISION MORE THAN 500 FEET FROM A PUBLIC ROAD**

**NOTES:**

1. PRIVATE ROAD TO BE USED ON MINOR SUBDIVISIONS ONLY AND SHALL BE SURFACED WITH 0.5' CLASS 2 AGGREGATE BASE ROCK OR EQUIVALENT, COMPACTED TO 95% WITH A PENETRATION COAT OF LIQUID ASPHALT.
2. PRIVATE ACCESS ROADS TO BE USED ON MINOR SUBDIVISIONS ONLY AS INTERIM ACCESS.
3. CROSS SLOPE SHALL BE 2% CROWNED FROM CENTERLINE, UNLESS DIRECTED OTHERWISE BY DEPARTMENT OF PUBLIC WORKS.
- \* 4. ROADWAY CUT AND FILL SLOPE TO BE DETERMINED BY GEOTECHNICAL ENGINEER.
- \* SEE A-4, NOTE 3.

COUNTY OF SAN MATEO DEPARTMENT  
OF

PUBLIC WORKS

.....  
REDWOOD CITY  
CALIFORNIA

DRAWN BY: A.Z.  
CHECKED BY: K.L.  
APPROVED BY: A.M.S.

SCALE: NONE  
DATE: 2-2022  
REVISED: 2-2022

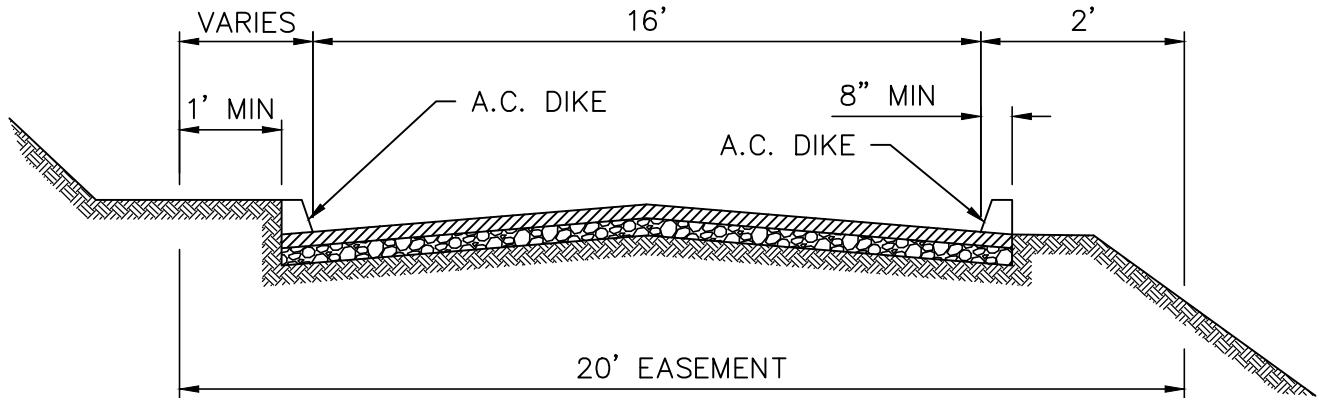

URBAN PRIVATE STREET

NOTES:

1. CROSS SLOPE SHALL BE 2% CROWNED FROM CENTERLINE, UNLESS DIRECTED OTHERWISE BY DEPARTMENT OF PUBLIC WORKS.
  2. A.C. DIKE WHERE NEEDED TO CONTROL STORM RUNOFF.
  - \* 3. ROADWAY CUT AND FILL SLOPE TO BE DETERMINED BY SOILS ENGINEER.
  4. STRUCTURAL SECTION AS DETERMINED BY GEOTECHNICAL ENGINEER AND APPROVED BY THE DEPARTMENT OF PUBLIC WORKS. (MINIMUM ALLOWABLE 0.2' ASPHALT CONCRETE OVER 0.5' CLASS 2 AGGREGATE BASE).
  5. PRIVATE STREET TO BE USED ON EITHER MAJOR OR MINOR SUBDIVISIONS TO SERVE ULTIMATELY FOUR OR LESS LOTS OR PARCELS.
- \* SEE A-4, NOTE 3.

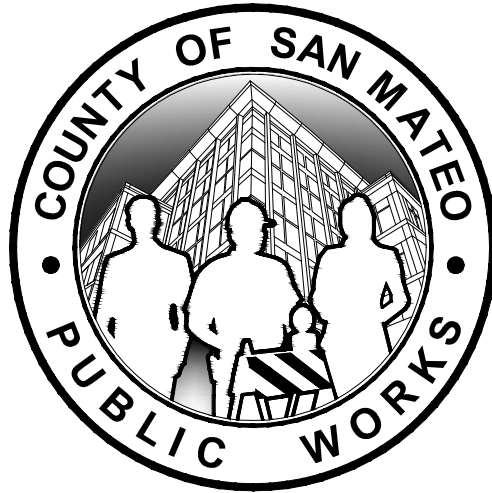

STANDARD DRAWINGS

FOR

PUBLIC IMPROVEMENT

---

**STORM  
DRAINAGE  
STANDARDS**

**COUNTY OF SAN MATEO DEPARTMENT  
OF**

DRAWN BY: A.Z.  
 CHECKED BY: K.L.  
 APPROVED BY: A.M.S.

**PUBLIC WORKS**

.....  
 REDWOOD CITY  
 CALIFORNIA

SCALE: NONE  
 DATE: 2-2022  
 REVISED: 2-2022

Curb Type	Normal Curb Height	Curb Batter	b
A1-6	6"	1 1/2"	12 1/2"
A1-8	8"	2"	12
B	6"	4"	10
Dike	6"	3"	11

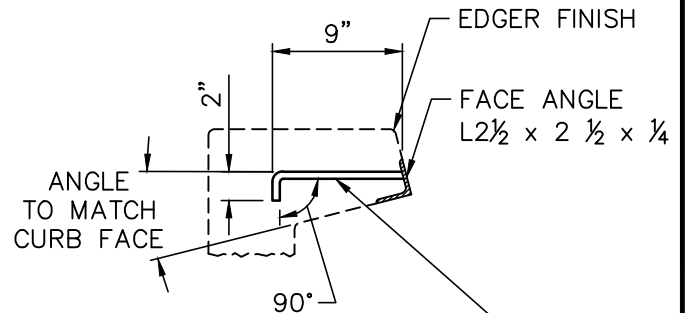

1/2" Ø MIN ANCHORS INSTALLED IN CENTER OF ADJACENT WALLS AT INLET OPENING AND @ 2'-6" CENTER TO CENTER ELSEWHERE

**ANCHOR DETAIL**

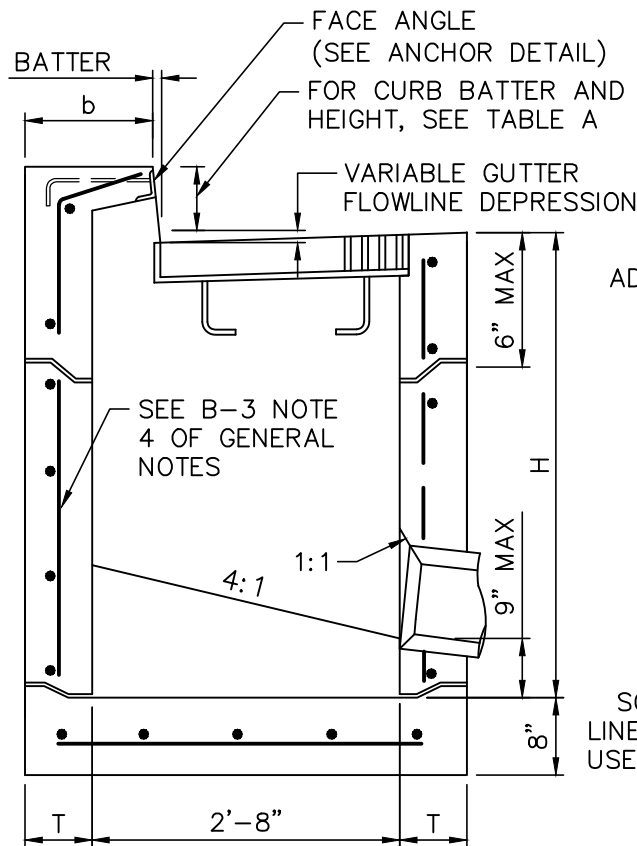

**SECTION A-A**

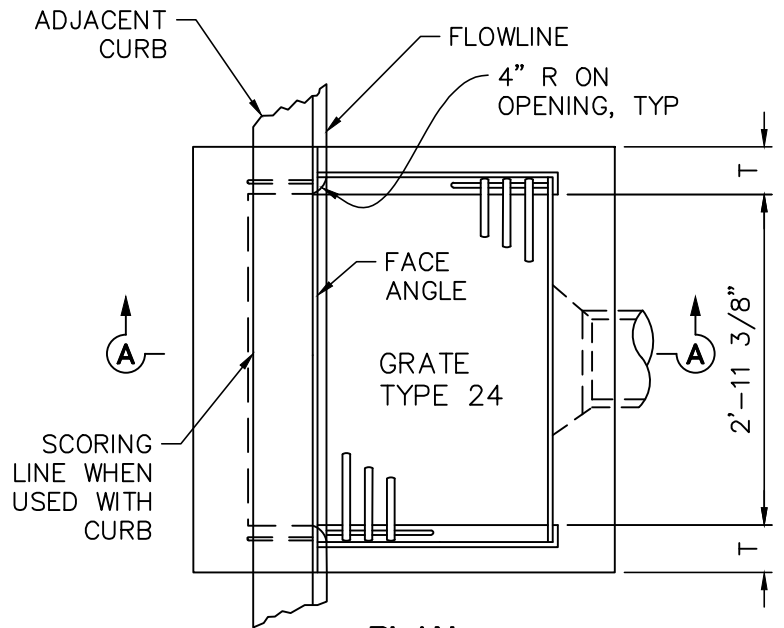

**PLAN**

**TYPE GO INLET**

	H=3'-0" TO 8'-0" (T=6")		H=8'-1" TO 20'-0" (T=8")	
	H=3'-0" (CY)	ADDITIONAL PCC PER FT (CY)	H=8'-1" (CY)	ADDITIONAL PCC PER FT (CY)
GO	1.26	0.245	4.90	0.506

TABLE B BASED ON 8" FLOOR SLAB, NO DEDUCTION FOR PIPE OPENINGS, AND CURB TYPE GIVING HIGHEST QUANTITY OF CONCRETE. NO DEDUCTIONS OR ADJUSTMENTS ARE TO BE MADE TO THESE QUANTITIES BECAUSE OF PIPE OPENINGS, DIFFERENT FLOOR ALTERNATIVES OR DIFFERENT CURB TYPE.

**COUNTY OF SAN MATEO DEPARTMENT  
OF**

**PUBLIC WORKS**

.....  
REDWOOD CITY  
CALIFORNIA

DRAWN BY: A.Z.  
CHECKED BY: K.L.  
APPROVED BY: A.M.S.

SCALE: NONE  
DATE: 2-2022  
REVISED: 2-2022

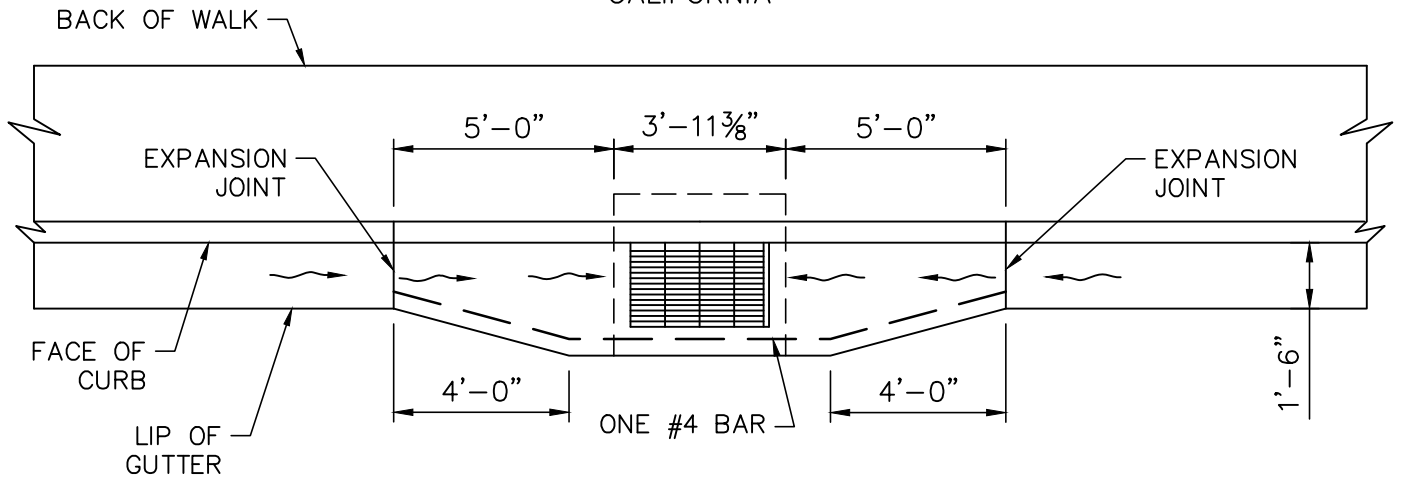

**TYPE GO INLET ON SAG**

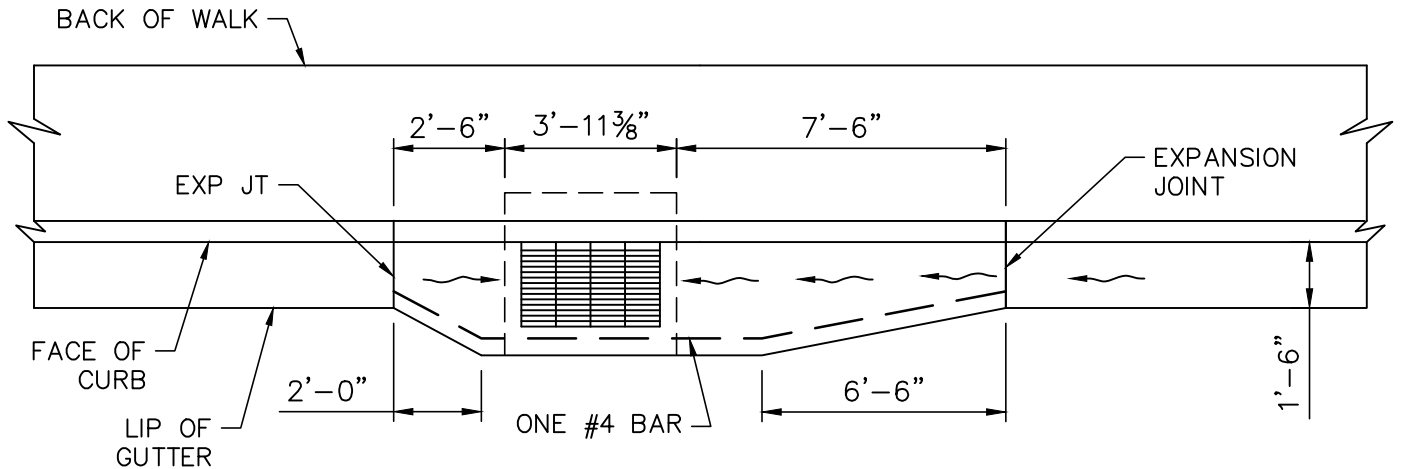

**TYPE GO INLET ON GRADE**

QUANTITY OF PCC FOR APRONS (CUBIC YARD)		
INLET	ON GRADE	IN SAG
GO	0.3843	0.3880

**NOTE:**

1. EXPANSION JOINT FILLER MUST COMPLY WITH ASTM D1751. NO FOAM OR OTHER MATERIALS. FILLER MUST BE 1/4" TO 1/2" MAX THICKNESS.

**APRON DETAILS**

**COUNTY OF SAN MATEO DEPARTMENT  
OF**

DRAWN BY: A.Z.  
CHECKED BY: K.L.  
APPROVED BY: A.M.S.

**PUBLIC WORKS**

.....  
REDWOOD CITY  
CALIFORNIA

SCALE: NONE  
DATE: 2-2022  
REVISED: 2-2022

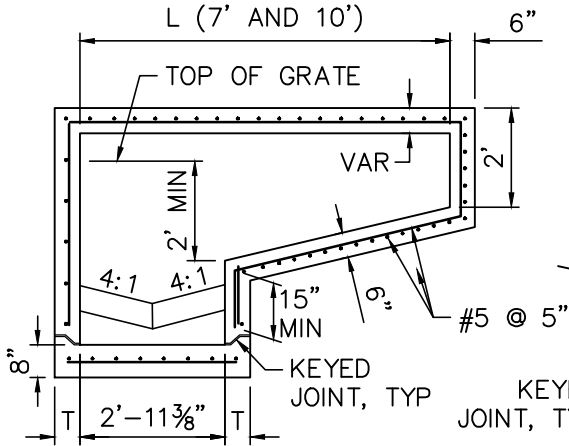

**SECTION A-A**

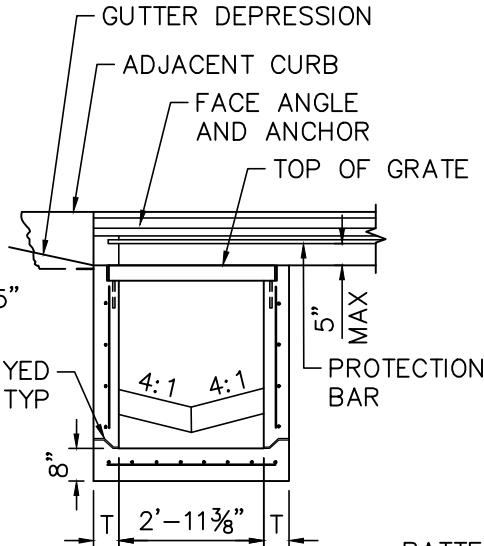

**SECTION B-B**

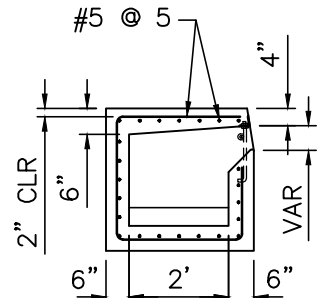

**SECTION C-C**

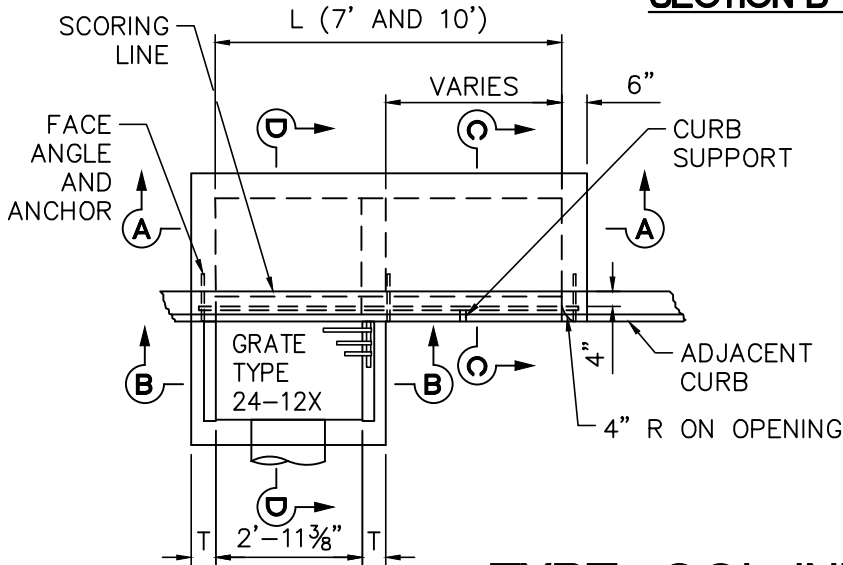

**PLAN**

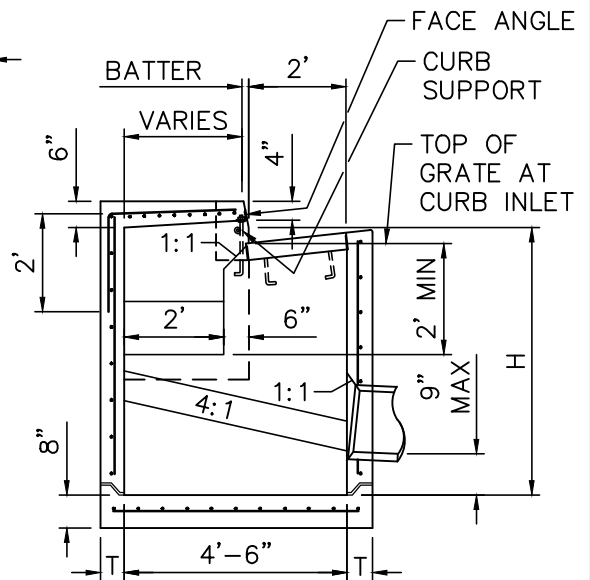

**SECTION D-D**

**TYPE GOL INLET**

CATCH BASIN QUANTITY TABLE				
TYPE	H=3'-0" TO 8'-0" (T=6")		H=8'-1" TO 20'-0" (T=8")	
	H=3'-0" (CY)	ADDITIONAL PCC PER FT (CY)	H=8'-1" (CY)	ADDITIONAL PCC PER FT (CY)
GOL-7	2.48	0.313	6.89	0.63
GOL-10	3.41	0.313	7.85	0.63

TABLE BASED ON 8" FLOOR SLAB, NO DEDUCTION FOR PIPE OPENINGS, 7" CURB OPENINGS, & CURB TYPE GIVING HIGHEST QUANTITY OF CONCRETE. NO DEDUCTIONS OR ADJUSTMENTS ARE TO BE MADE TO THESE QUANTITIES BECAUSE OF PIPE OPENINGS, DIFFERENT CURB TYPES OR DIFFERENT HEIGHT OF CURB OPENINGS.





**COUNTY OF SAN MATEO DEPARTMENT  
OF**

DRAWN BY: A.Z.  
CHECKED BY: K.L.  
APPROVED BY: A.M.S.

**PUBLIC WORKS**

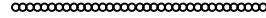

REDWOOD CITY  
CALIFORNIA

SCALE: NONE  
DATE: 2-2022  
REVISED: 2-2022

GENERAL NOTES:

1. "H" IS THE DIFFERENCE IN ELEVATION BETWEEN THE OUTLET PIPE FLOW LINE AND THE NORMAL GUTTER GRADE LINE UNDEPRESSED AT THE CURB FACE.
2. FOR "T" WALL THICKNESS SEE TABLE.
3. HEIGHT OF CURB OPENING WILL VARY WITH THE TYPE OF CURB AND THE DEPTH OF THE LOCAL DEPRESSION.
4. WALL REINFORCING NOT REQUIRED WHEN  $H = 8'$  OR LESS AND THE UNSUPPORTED WIDTH OR LENGTH =  $7'$  OR LESS. WALLS EXCEEDING THESE LIMITS SHALL BE REINFORCED WITH #4 BARS @  $18'' \pm$  CENTERS PLACED  $1-1/2''$  CLEAR TO INSIDE OF BOX UNLESS OTHERWISE SHOWN.
5. WHEN SHOWN ON THE PROJECT PLANS, PLACE A #6 PROTECTION BAR HORIZONTALLY ACROSS THE ENTIRE LENGTH OF THE OPENING AND BEND BACK 4" INTO THE INLET WALL ON EACH SIDE.
6. CURB SUPPORTS SHALL BE EVENLY SPACED AND MINIMAL IN NUMBER SUCH THAT MAXIMUM SPAN OF UNSUPPORTED CURB IS 7'.
7. EXCEPT FOR INLETS USED AS JUNCTION BOXES, BASIN FLOOR SHALL HAVE A MINIMUM SLOPE OF 4:1 FROM ALL DIRECTIONS TOWARD OUTLET PIPE AND SHALL HAVE A WOOD TROWEL FINISH.
8. GALVANIZING: SEE STANDARD SPECIFICATION OR SPECIAL PROVISIONS.
9. SEE STANDARD PLAN D78 FOR DEPRESSION DETAILS NOT SHOWN.
10. COMPLETE JOINT PENETRATION BUTT WELDS MAY BE SUBSTITUTED FOR THE FILLET WELDS ON ALL ANCHORS.
11. STANDARD SQUARE, HEXAGON, ROUND OR EQUIVALENT HEADED ANCHORS MAY BE SUBSTITUTED FOR THE RIGHT ANGLE HOOKS ON THE ANCHORS SHOWN ON THIS PLAN.
12. CAST-IN-PLACE OR PRECAST ALTERNATIVE IS OPTIONAL WITH CONTRACTOR. SEE STANDARD SPECIFICATIONS.

**STORM DRAINAGE INLETS**

**COUNTY OF SAN MATEO DEPARTMENT  
OF**

**PUBLIC WORKS**

.....  
REDWOOD CITY  
CALIFORNIA

DRAWN BY: A.Z.  
CHECKED BY: K.L.  
APPROVED BY: A.M.S.

SCALE: NONE  
DATE: 2-2022  
REVISED: 2-2022

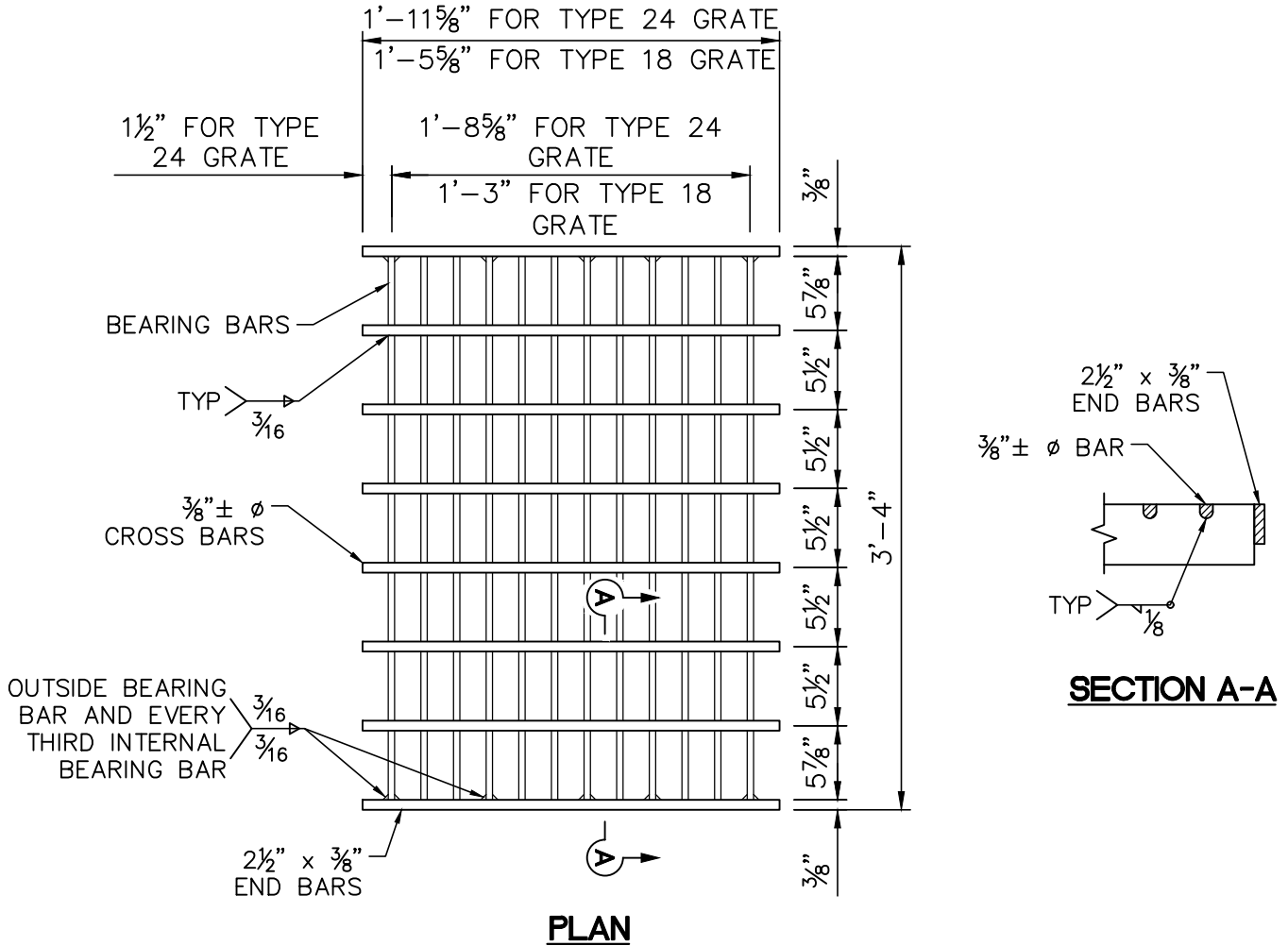

**TYPE 24-12X GRATE**  
(WELDED STEEL)

MISC IRON AND STEEL FINAL PAY WEIGHT FOR DRAINAGE INLETS			
INLET TYPE	GRATE TYPE	NO. GRATES	WEIGHT LBS.
GO, GOL	24-12X	1	239

**NOTES:**

1. ALL STEEL TO BE HOT DIP GALVANIZED AFTER ALL WELDING IS COMPLETE.
2. BEARING BARS TO BE 3 1/2" x 3/8" BARS ON 1/8" CENTERS.
3. 12 BARS FOR TYPE 24 GRATE - 9 BARS FOR TYPE 18 GRATES.

**COUNTY OF SAN MATEO DEPARTMENT  
OF  
PUBLIC WORKS**

DRAWN BY: A.Z.  
 CHECKED BY: K.L.  
 APPROVED BY: A.M.S.

.....  
 REDWOOD CITY  
 CALIFORNIA

SCALE: NONE  
 DATE: 2-2022  
 REVISED: 2-2022

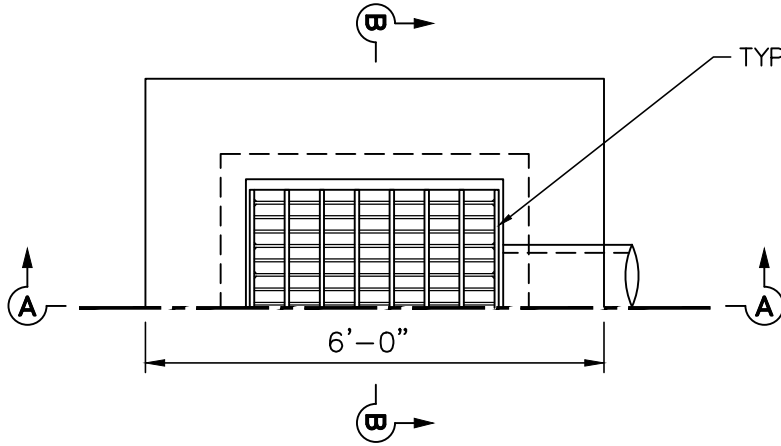

**PLAN**

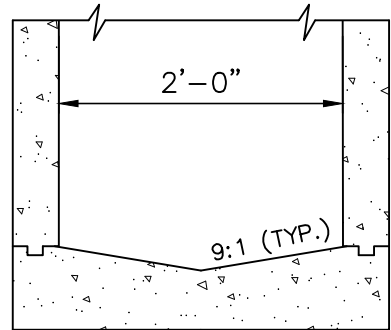

NOTE: REBAR NOT SHOWN.

**SECTION B-B**

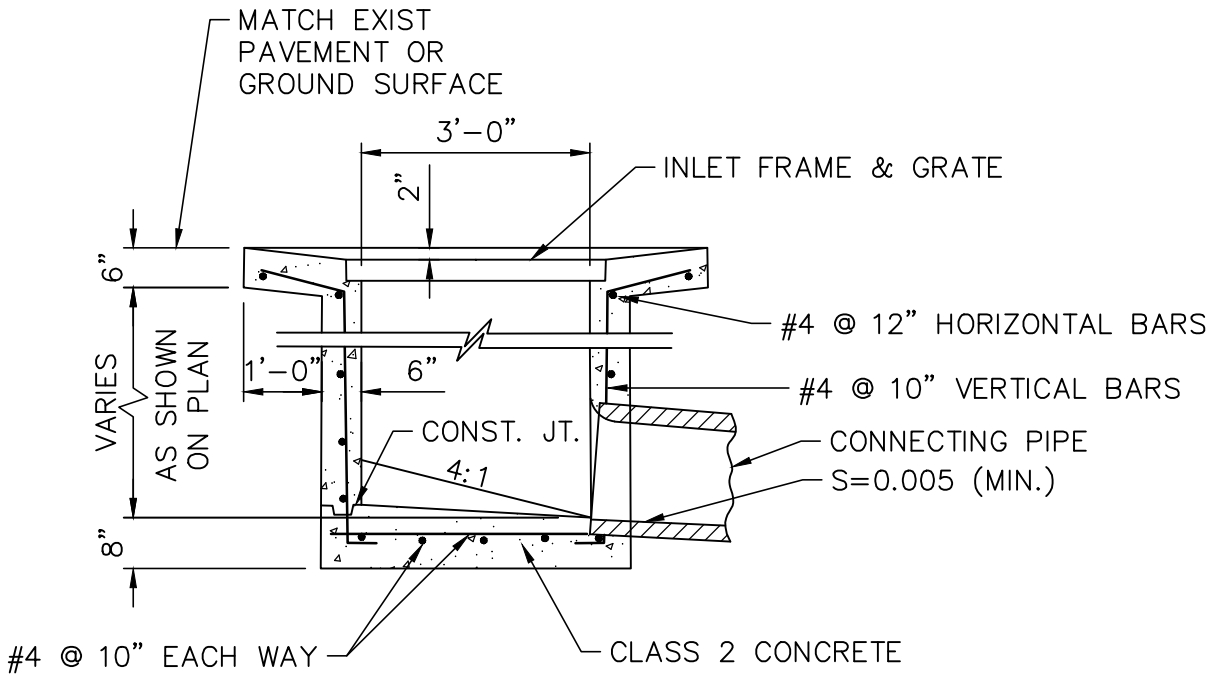

**SECTION A-A**

**TRAFFIC INLET**

**COUNTY OF SAN MATEO DEPARTMENT  
OF**

DRAWN BY: A.Z.  
 CHECKED BY: K.L.  
 APPROVED BY: A.M.S.

**PUBLIC WORKS**

.....  
 REDWOOD CITY  
 CALIFORNIA

SCALE: NONE  
 DATE: 2-2022  
 REVISED: 2-2022

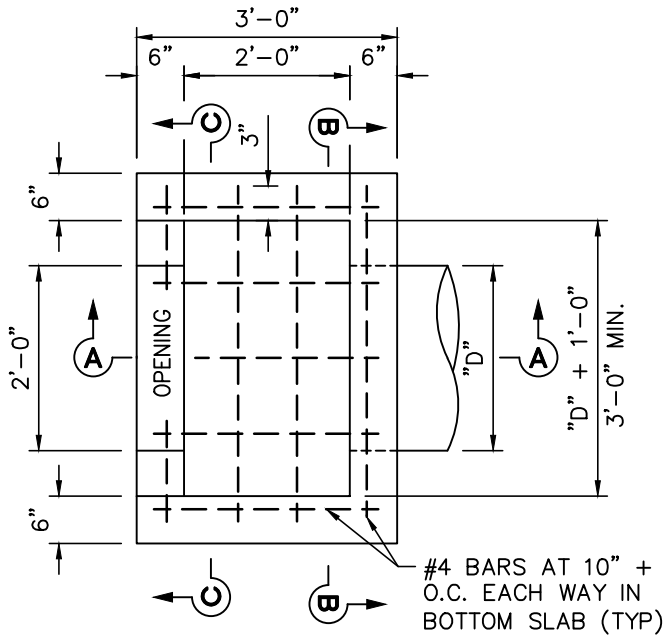

**PLAN**

**3' X 2' DROP INLET**

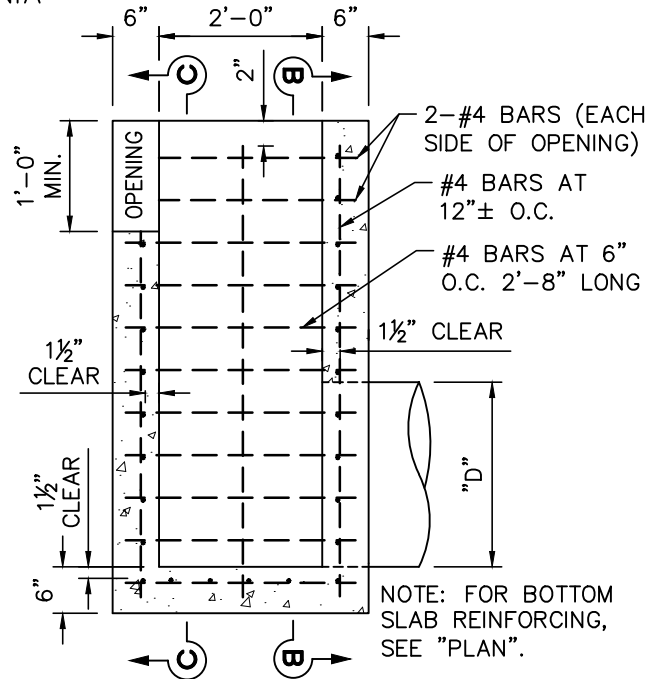

**SECTION A-A**

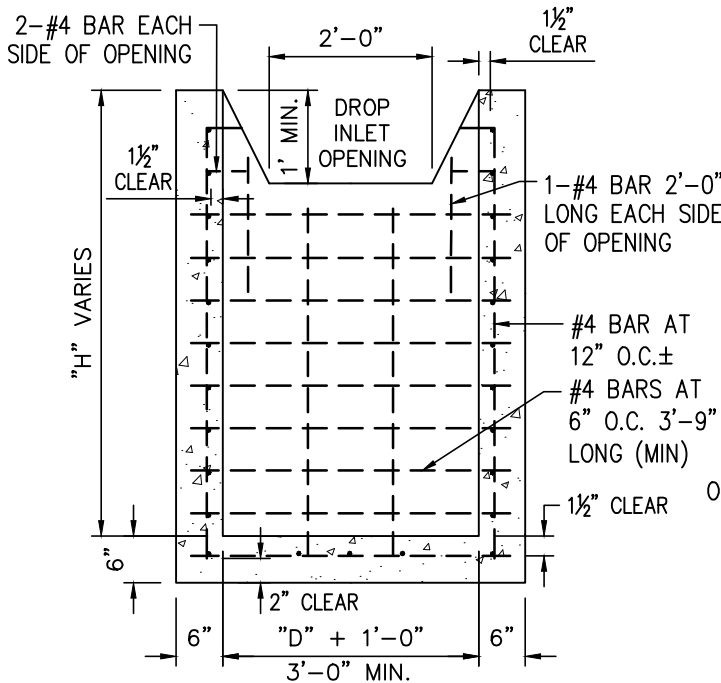

**SECTION C-C**

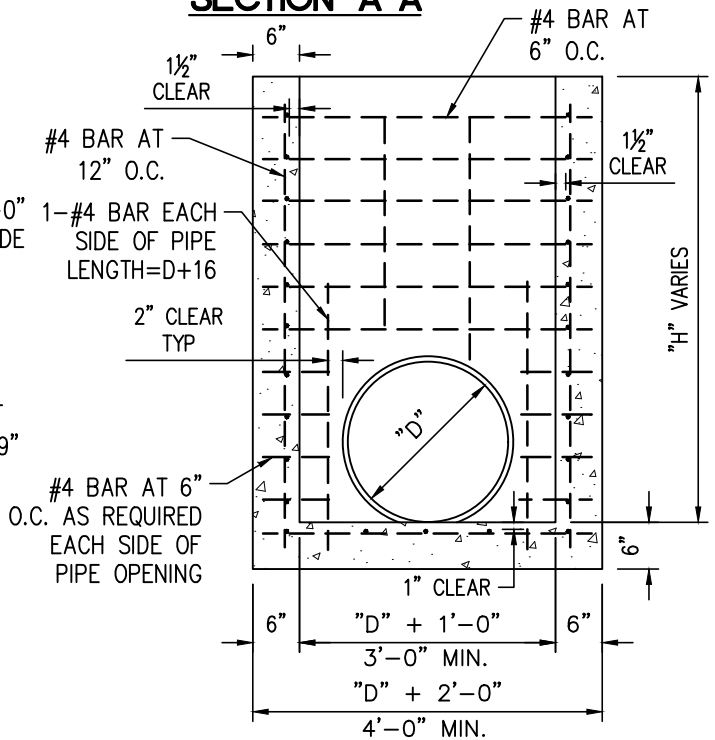

**SECTION B-B**

**DROP INLET**

COUNTY OF SAN MATEO DEPARTMENT  
OF

PUBLIC WORKS

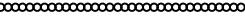

REDWOOD CITY  
CALIFORNIA

DRAWN BY: A.Z.  
CHECKED BY: K.L.  
APPROVED BY: A.M.S.

SCALE: NONE  
DATE: 2-2022  
REVISED: 2-2022

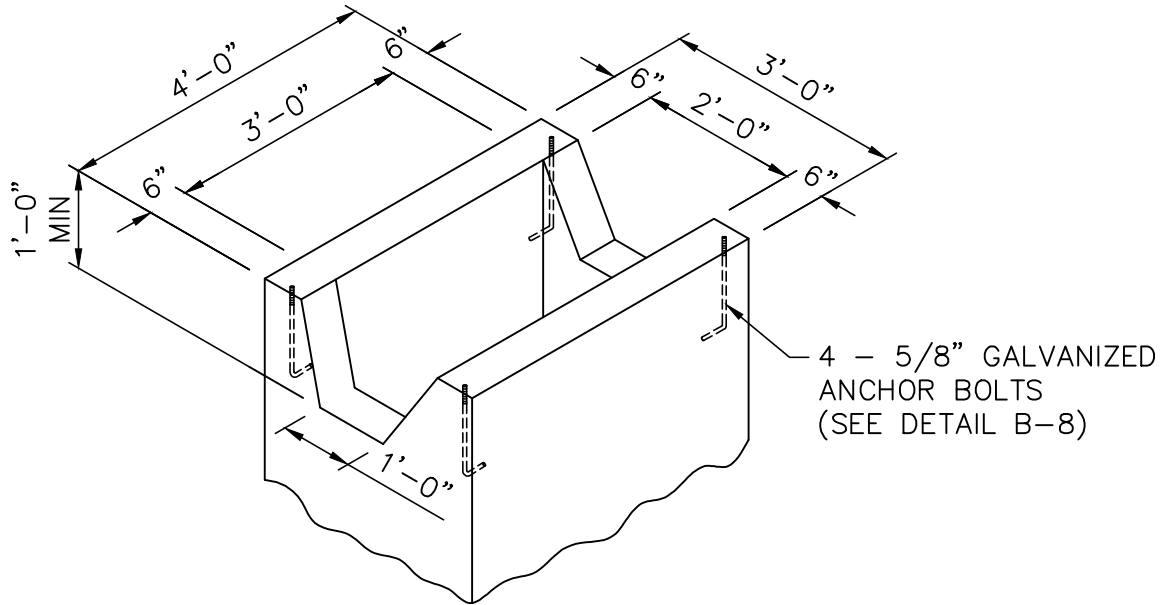

**DROP INLET W/ END OPENING**

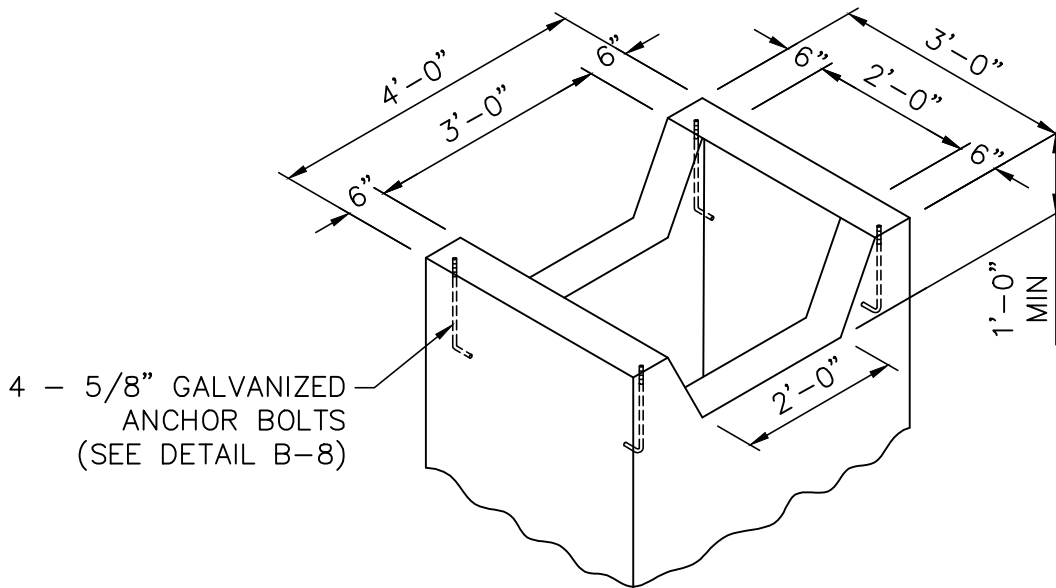

**DROP INLET W/ SIDE OPENING**

**DROP INLET DETAIL**

COUNTY OF SAN MATEO DEPARTMENT  
OF  
PUBLIC WORKS

DRAWN BY: A.Z.  
CHECKED BY: K.L.  
APPROVED BY: A.M.S.

.....  
REDWOOD CITY  
CALIFORNIA

SCALE: NONE  
DATE: 2-2022  
REVISED: 2-2022

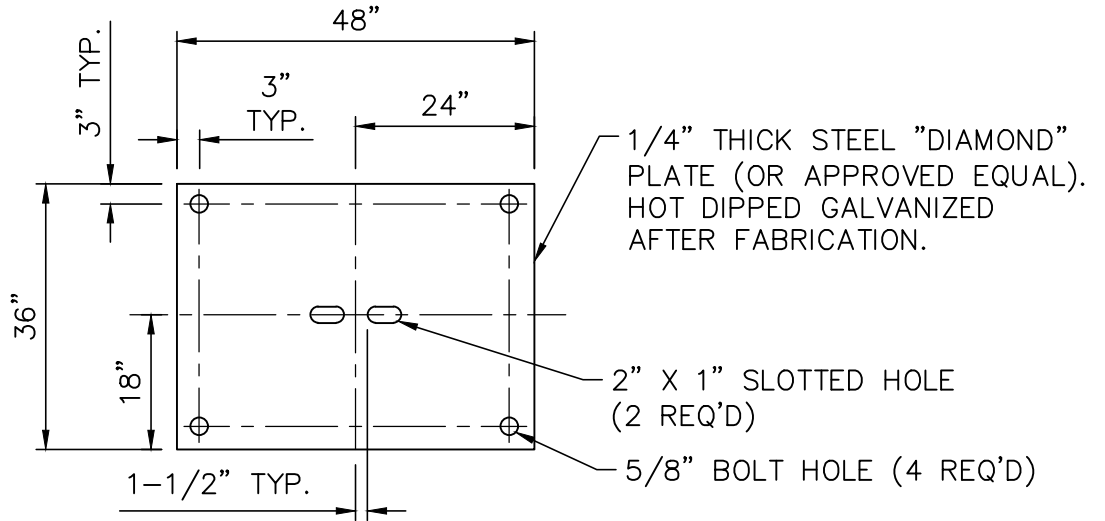

**COVER PLATE DETAIL**

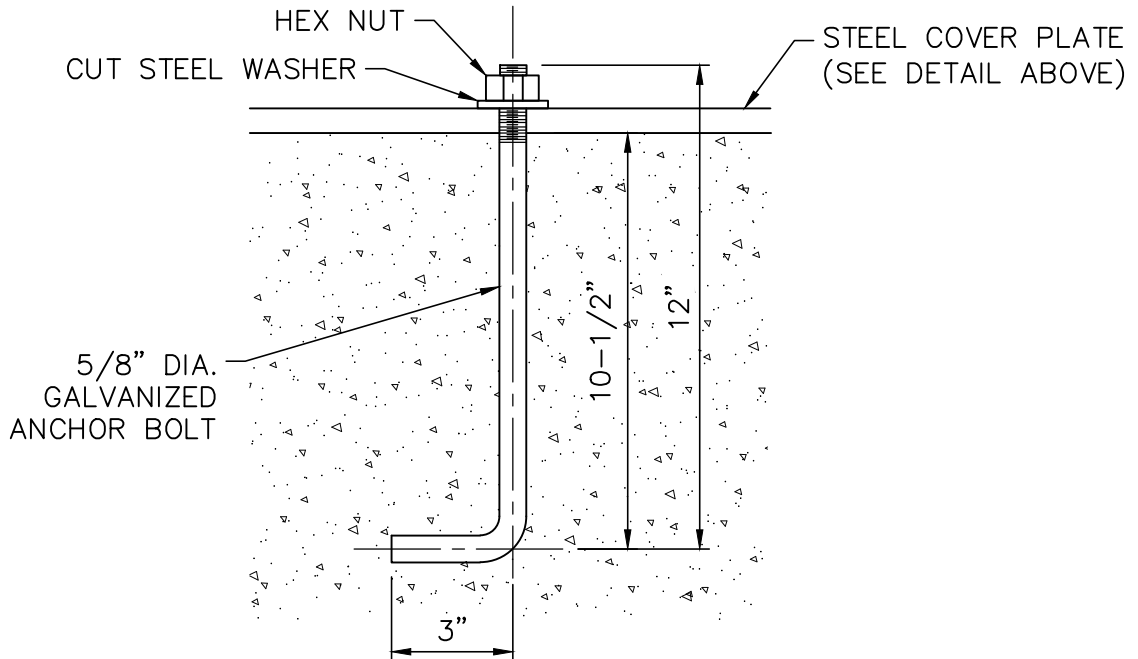

**ANCHOR BOLT DETAIL**

**DROP INLET DETAIL**

**COUNTY OF SAN MATEO DEPARTMENT  
OF  
PUBLIC WORKS**

DRAWN BY: A.Z.  
CHECKED BY: K.L.  
APPROVED BY: A.M.S.

.....  
REDWOOD CITY  
CALIFORNIA

SCALE: NONE  
DATE: 2-2022  
REVISED: 2-2022

**NOTE:**

w - VARIES WITH PIPE SIZE (SEE TABLE 1)

PIPE SIZE	w
15	22"
18	21"
21	20"
24	19"
27	18"

**TABLE 1**

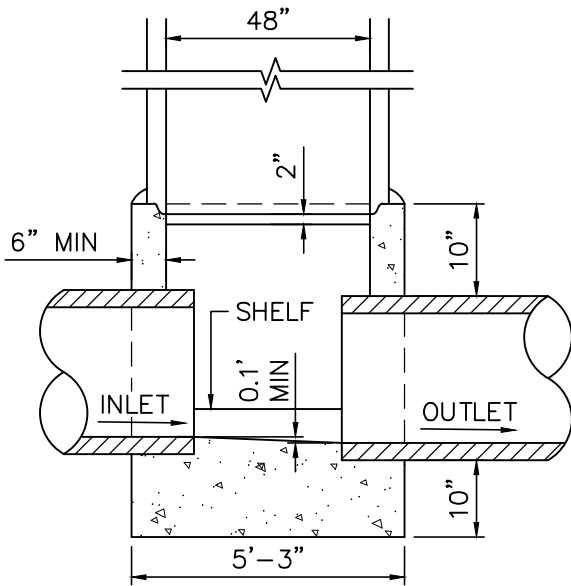
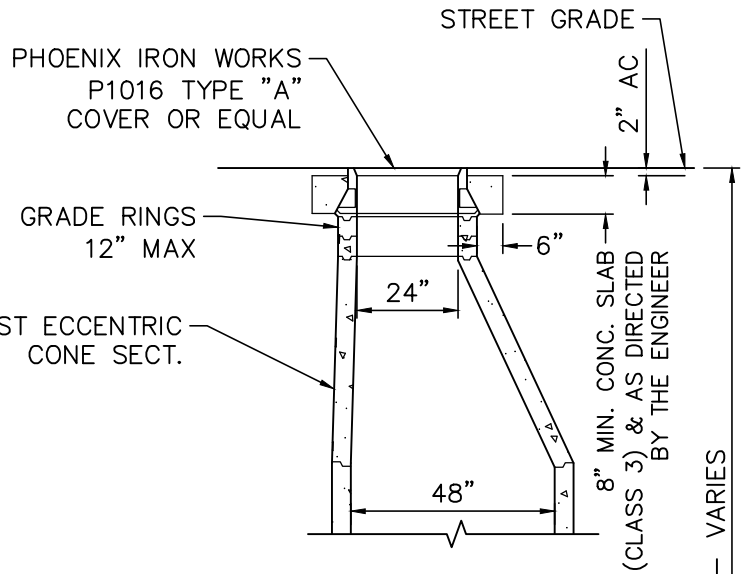
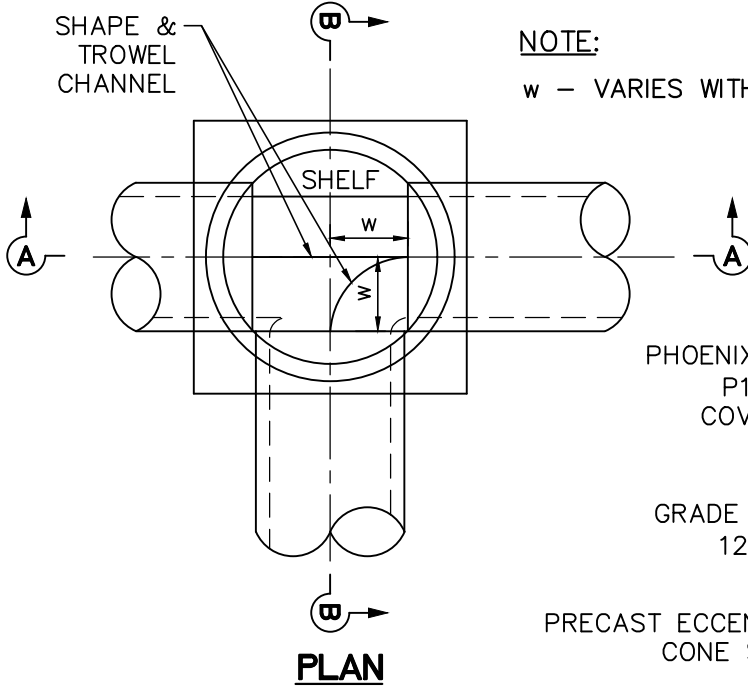

**SECTION A-A**

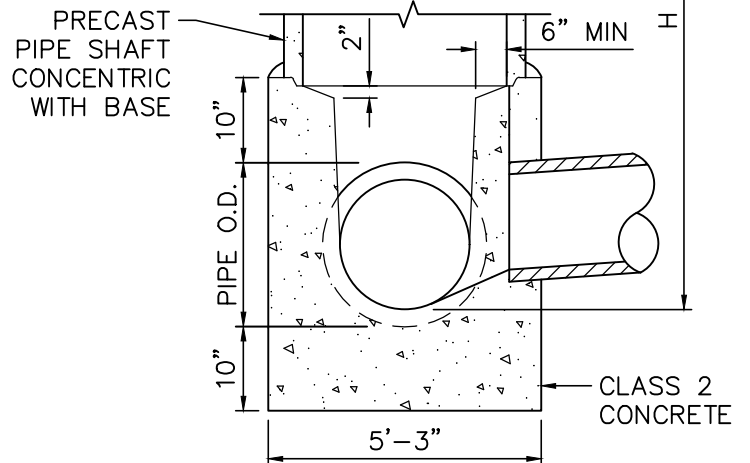

**SECTION B-B**

**STANDARD STORM DRAIN MANHOLE**



**COUNTY OF SAN MATEO DEPARTMENT  
OF**

**PUBLIC WORKS**

.....  
REDWOOD CITY  
CALIFORNIA

DRAWN BY: A.Z.  
CHECKED BY: K.L.  
APPROVED BY: A.M.S.

SCALE: NONE  
DATE: 2-2022  
REVISED: 2-2022

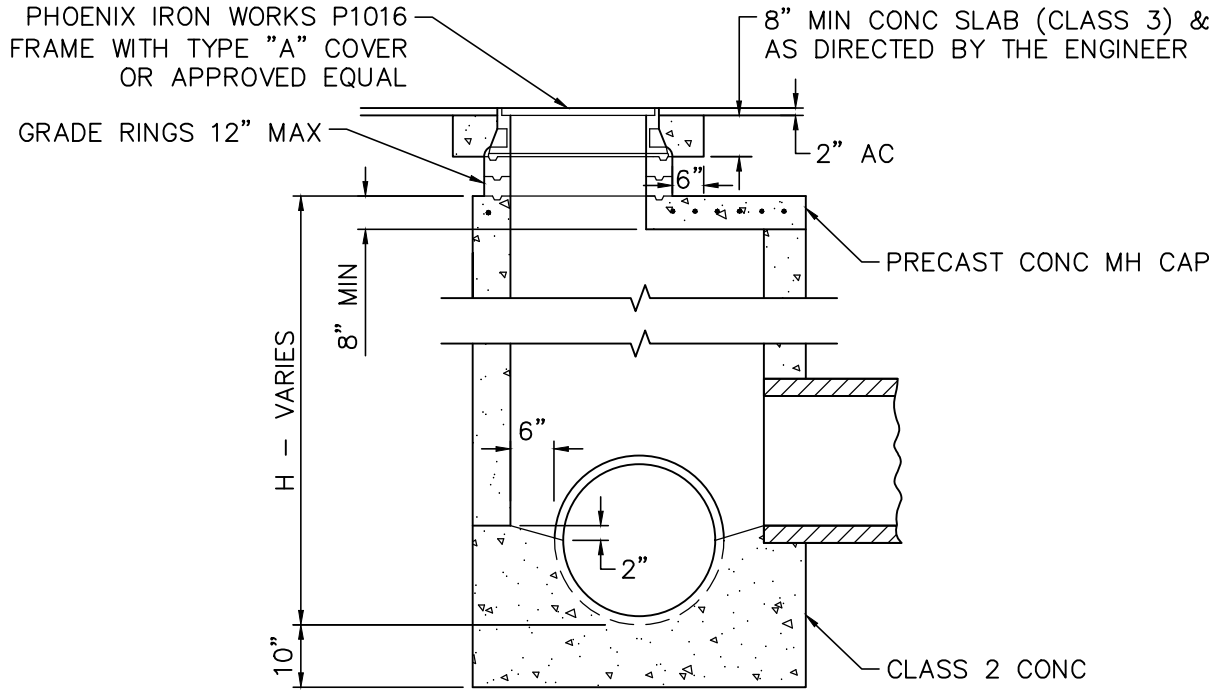

**SECTION A-A**

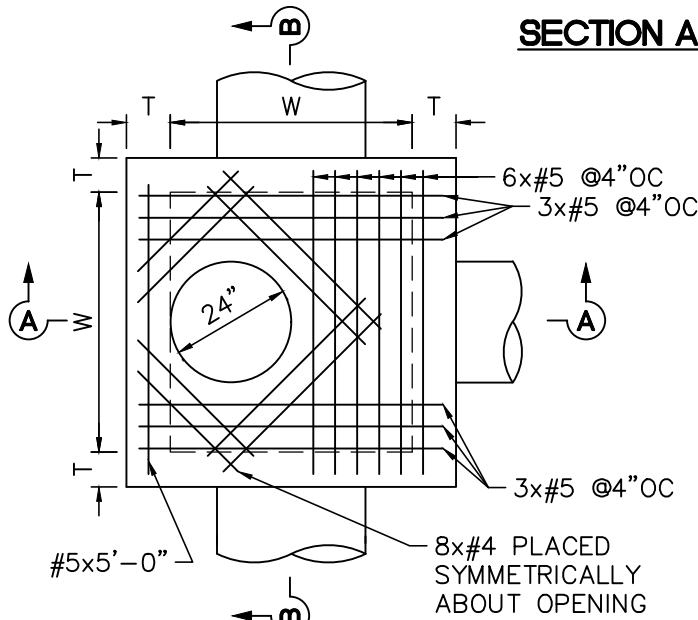

**PLAN**

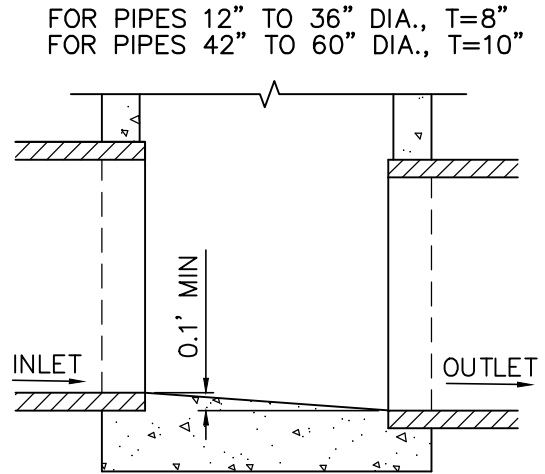

**SECTION B-B**

**STANDARD STORM DRAIN MANHOLE  
SHALLOW COVER**

**COUNTY OF SAN MATEO DEPARTMENT  
OF  
PUBLIC WORKS**

DRAWN BY: A.Z.  
 CHECKED BY: K.L.  
 APPROVED BY: A.M.S.

SCALE: NONE  
 DATE: 2-2022  
 REVISED: 2-2022

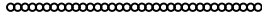

REDWOOD CITY  
CALIFORNIA

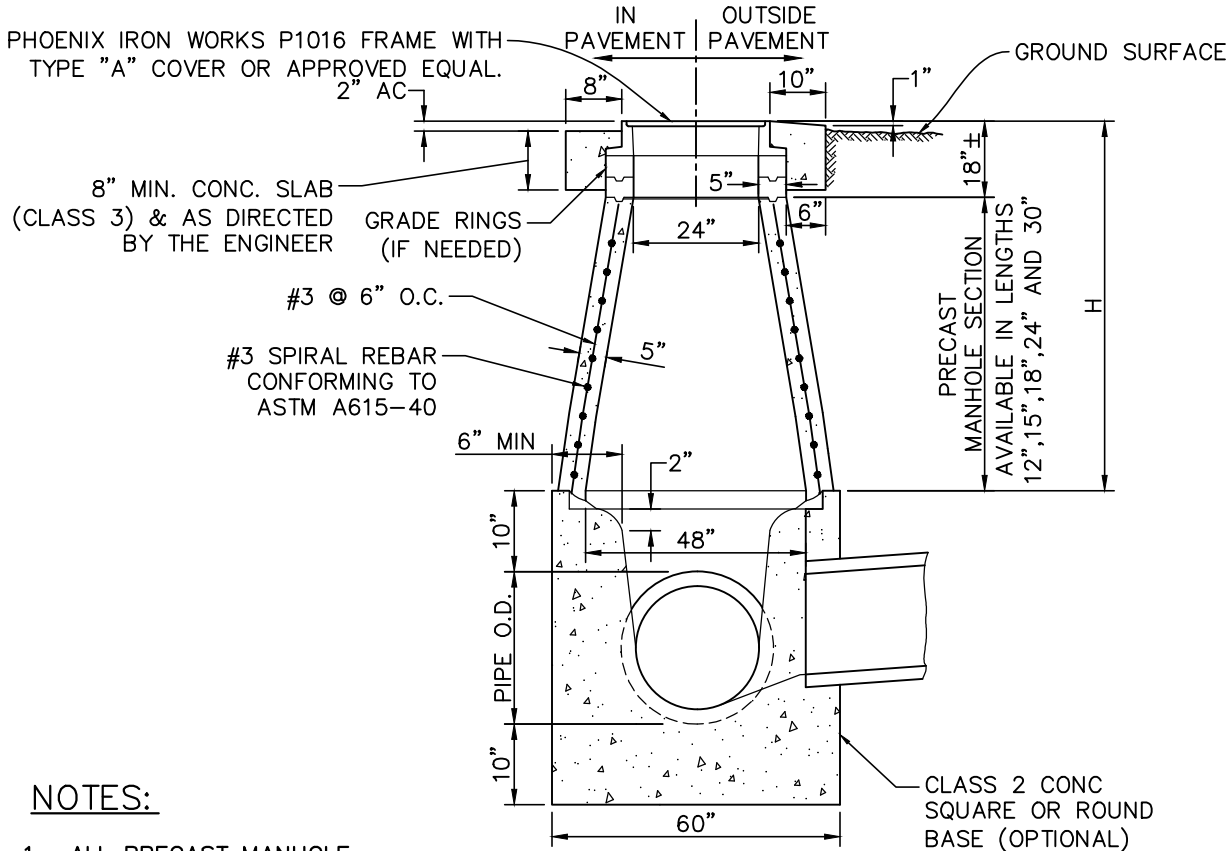

**NOTES:**

1. ALL PRECAST MANHOLE SECTIONS TO BE MANUFACTURED IN STRICT ACCORDANCE WITH THE LATEST PROVISIONS OF A.S.T.M. DESIGNATION C-478.
2. ALL 48" PRECAST SECTIONS SHALL HAVE 5" THICK WALLS.
3. MANHOLE BASE TO BE POURED ON UNDISTURBED EARTH OR ON 95% COMPACTED SOIL.
4. MANHOLE CASTING TO BE SET TO GRADE PRIOR TO PLACING 2" AC.

**SECTION**

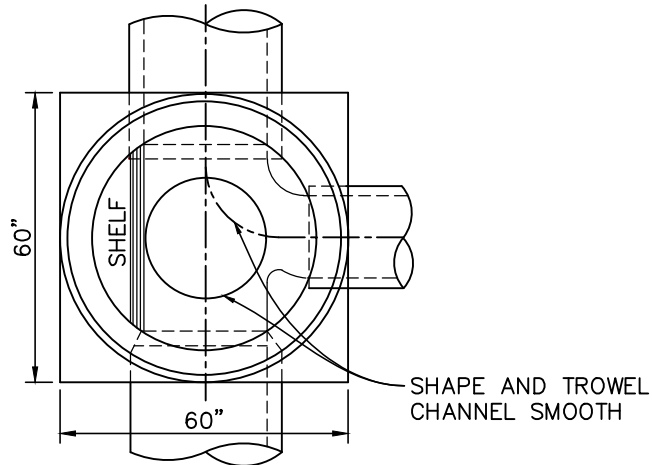

**PLAN**

**STORM DRAIN MANHOLE-SHALLOW COVER (H ≤ 42")  
(FOR PIPES 42" I.D. OR LESS)**

**COUNTY OF SAN MATEO DEPARTMENT  
OF**

**PUBLIC WORKS**

REDWOOD CITY  
CALIFORNIA

DRAWN BY: A.Z.  
CHECKED BY: K.L.  
APPROVED BY: A.M.S.

SCALE: NONE  
DATE: 2-2022  
REVISED: 2-2022

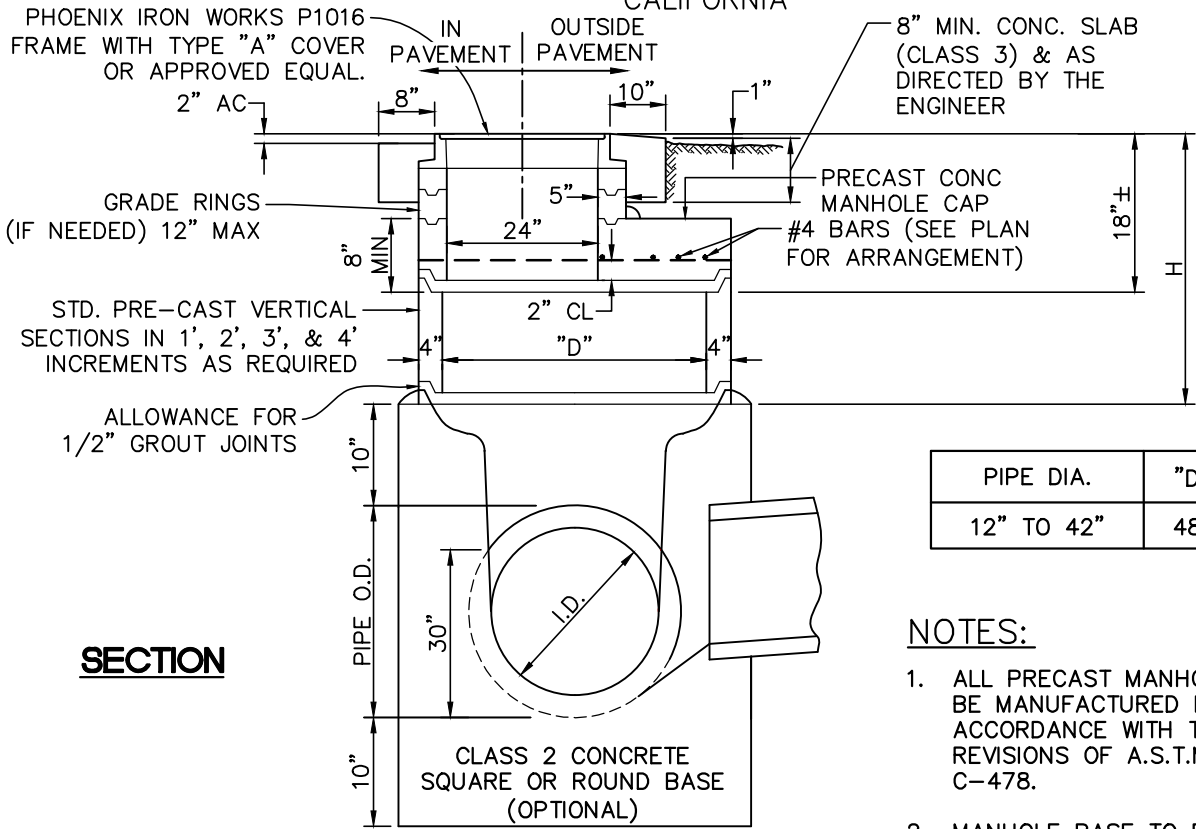

PIPE DIA.	"D"	"W"
12" TO 42"	48"	60"

**SECTION**

**NOTES:**

1. ALL PRECAST MANHOLE SECTIONS TO BE MANUFACTURED IN STRICT ACCORDANCE WITH THE LATEST REVISIONS OF A.S.T.M. DESIGNATION C-478.
2. MANHOLE BASE TO BE POURED ON UNDISTURBED EARTH OR ON 95% COMPACTED SOIL.
3. 1:3 GROUT MIX OR RAM-NEK JOINT COMPOUND TO BE USED IN ALL JOINTS.
4. MANHOLE CASTING TO BE SET TO GRADE PRIOR TO PLACING 2" ASPHALT CONCRETE.
5. ALL SLAB REINFORCING BARS TO BE #4.
6. #2 BARS BENT UP AND SPACED 6" O.C. AROUND 24" OPENING. HORIZONTAL LEG TO FAN OUT AT EQUAL SPACE TO 2" CLEARANCE AT EDGE OF SLAB.

**PLAN**

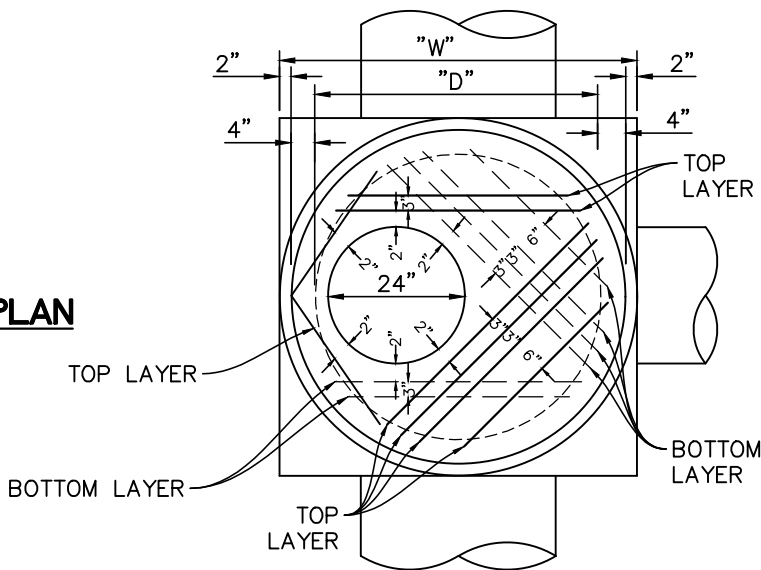

**STANDARD FLAT TOP STORM DRAIN MANHOLE**  
**(H ≤ 42", PIPES 42" ID OR LESS)**

**COUNTY OF SAN MATEO DEPARTMENT  
OF  
PUBLIC WORKS**

DRAWN BY: A.Z.  
 CHECKED BY: K.L.  
 APPROVED BY: A.M.S.

SCALE: NONE  
 DATE: 2-2022  
 REVISED: 2-2022

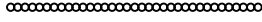

REDWOOD CITY  
CALIFORNIA

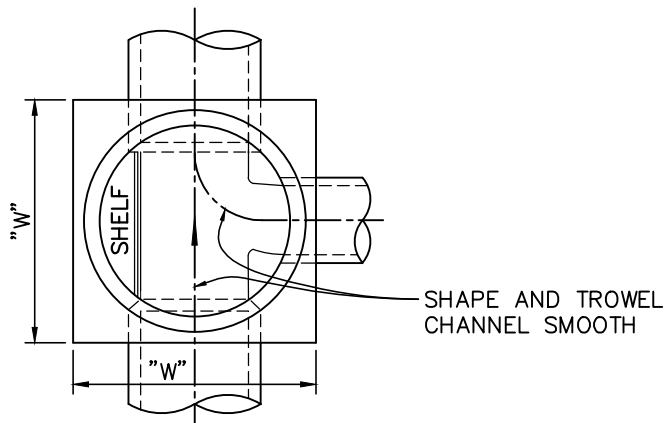
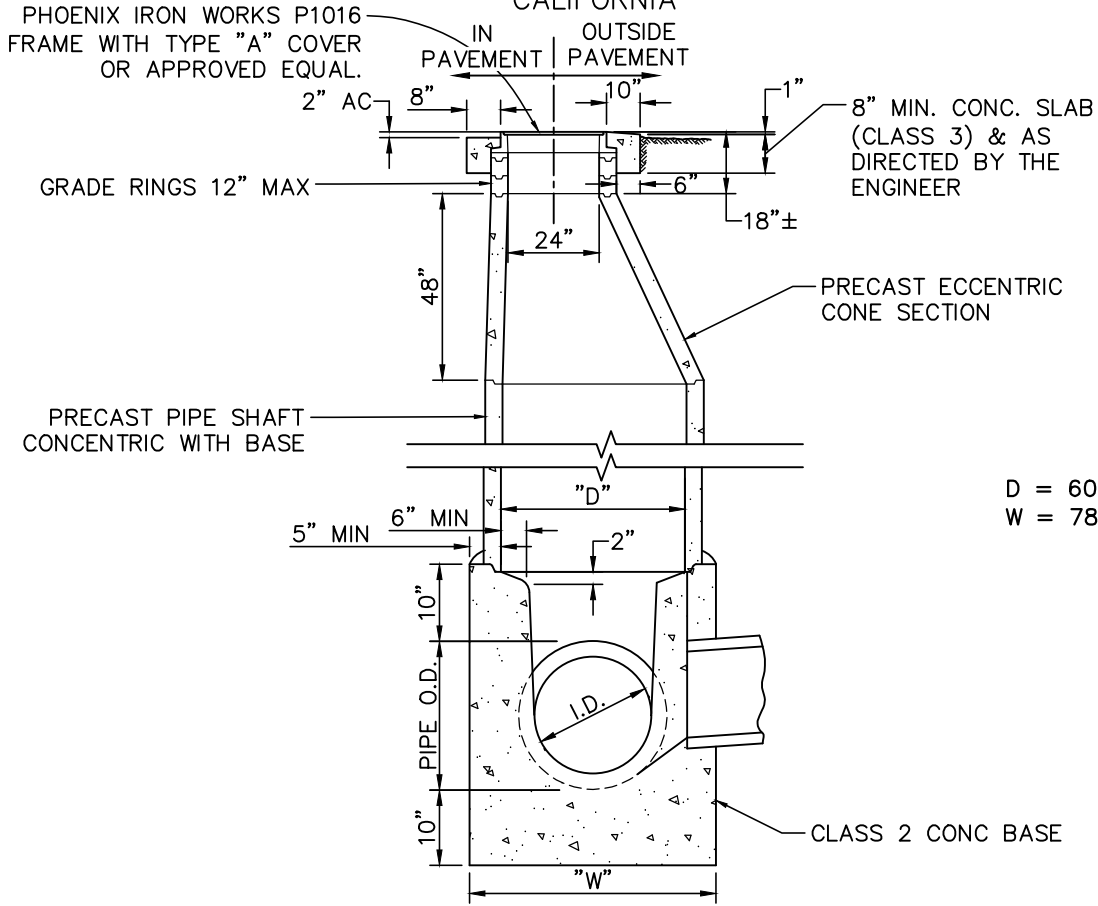

**STANDARD STORM DRAIN MANHOLE**  
**(FOR PIPES I.D. 45" TO 60")**

**COUNTY OF SAN MATEO DEPARTMENT  
OF**

DRAWN BY: A.Z.  
 CHECKED BY: K.L.  
 APPROVED BY: A.M.S.

**PUBLIC WORKS**

.....  
 REDWOOD CITY  
 CALIFORNIA

SCALE: NONE  
 DATE: 2-2022  
 REVISED: 2-2022

O.D.= OUTSIDE DIAMETER

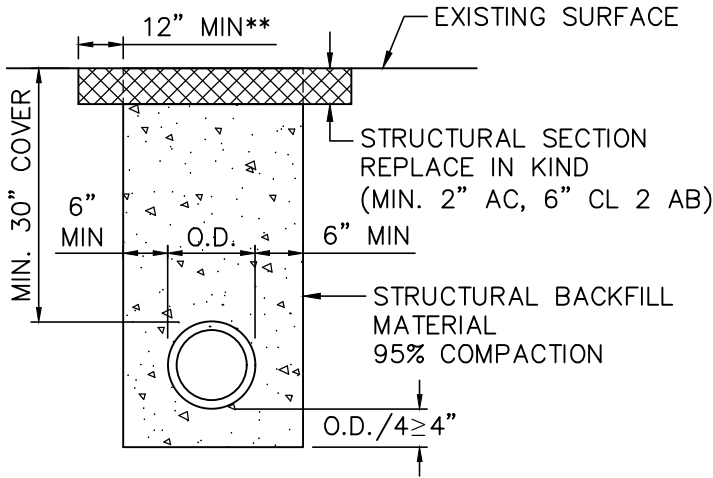

**TYPE A (IN ROADWAY)**

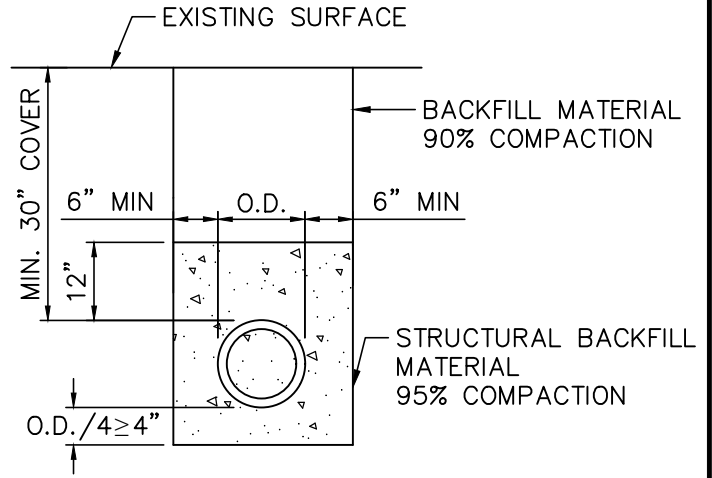

**TYPE B (OUTSIDE ROADWAY)**

THERE SHALL BE A MINIMUM OF TWO AND ONE-HALF FEET (30 INCHES) OF COVER OVER ALL PIPES AND CONDUITS UNLESS OTHERWISE APPROVED BY COUNTY ROAD INSPECTOR.

STRUCTURE BACKFILL MATERIAL – MATERIAL WITH SAND EQUIVALENT NOT LESS THAN 20 AND SIEVE GRADATION BY WEIGHT AS FOLLOWS:

SIEVE SIZE	% PASSING SIEVES
3"	100
NO.4	35-100
NO.30	20-100

BACKFILL MATERIAL – MATERIAL FROM EXCAVATION, FREE FROM STONES OR LUMPS EXCEEDING 3 INCHES IN GREATEST DIMENSION, VEGETABLE MATTER, OR OTHER UNSATISFACTORY MATERIAL.

\* IN AREAS OF CEMENT TREATED BASES, THE REPLACEMENT MATERIAL SHALL CONSIST OF A MINIMUM OF 3" OF ASPHALT CONCRETE (TYPE B) OVER A MINIMUM OF 8" OF PORTLAND CEMENT CONCRETE (CLASS 3).

FOR TRENCH BACKFILL REQUIREMENTS FOR SANITARY SEWER PIPE, SEE STANDARD DRAWINGS C6 AND C7.

\*\* ON TRENCHES THAT PARALLEL THE ROAD AND ARE WITHIN EXISTING BICYCLE LANES, THE WIDTH OF THE STRUCTURAL SECTION SHALL BE GREATER THAN OR EQUAL TO THE WIDTH OF THE EXISTING BICYCLE LANE.

**STANDARD TRENCH BACKFILL AND BEDDING  
DETAIL FOR STORM DRAIN PIPES**

**COUNTY OF SAN MATEO DEPARTMENT  
OF**

**PUBLIC WORKS**

.....  
REDWOOD CITY  
CALIFORNIA

DRAWN BY: A.Z.  
CHECKED BY: K.L.  
APPROVED BY: A.M.S.

SCALE: NONE  
DATE: 2-2022  
REVISED: 2-2022

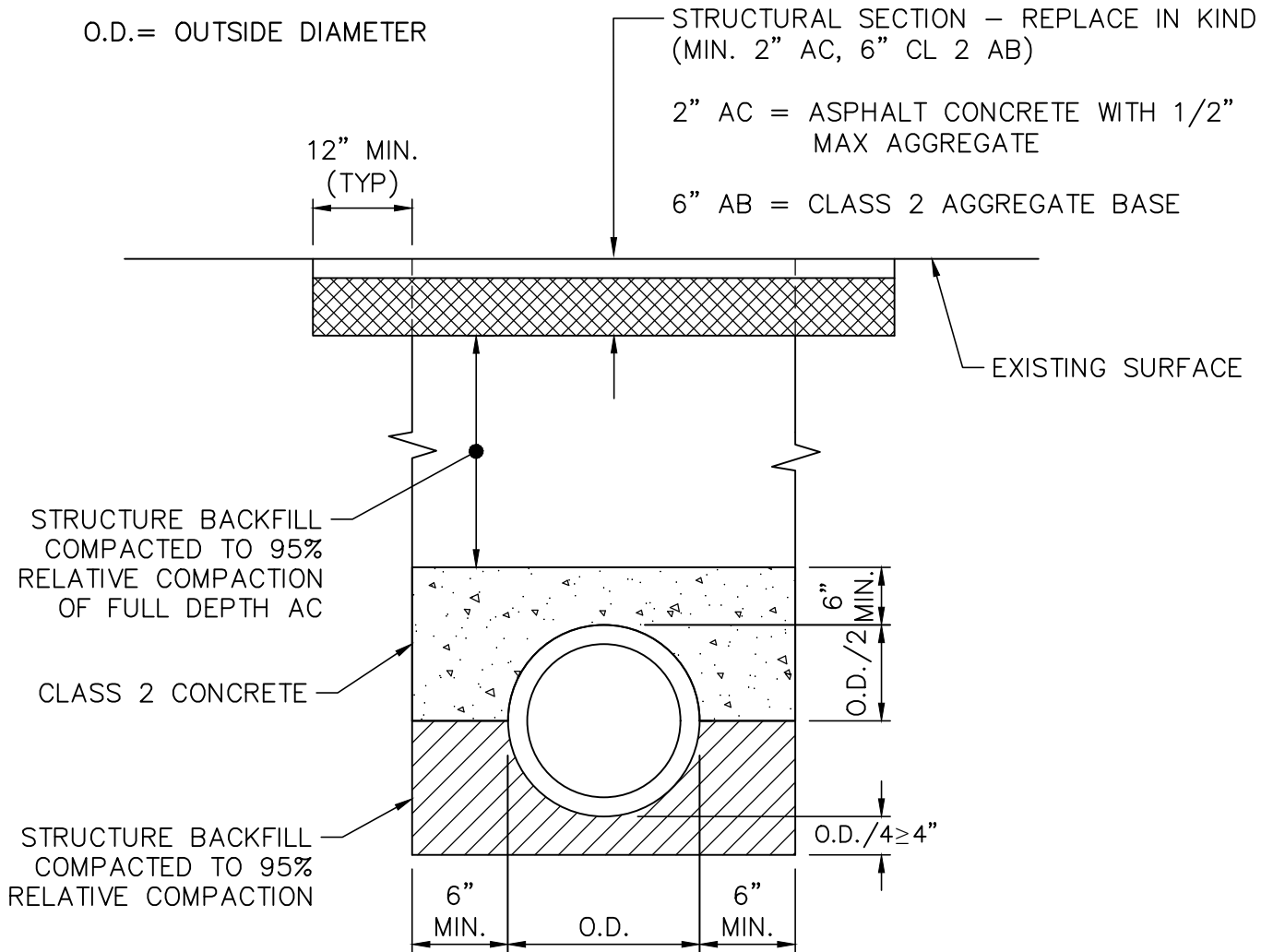

\* ON TRENCHES THAT PARALLEL THE ROAD AND ARE WITHIN EXISTING BICYCLE LANES, THE WIDTH OF THE STRUCTURAL SECTION SHALL BE GREATER THAN OR EQUAL TO THE WIDTH OF THE EXISTING BICYCLE LANE. PAVING JOINTS WITHIN THE BICYCLE LANE ARE NOT ALLOWED.

\*\* 95% RELATIVE COMPACTION = 95% OF MAXIMUM DENSITY USING EITHER THE STANDARD PROCTOR OR THE MODIFIED PROCTOR TEST METHODS.

**PIPE CAP DETAIL**

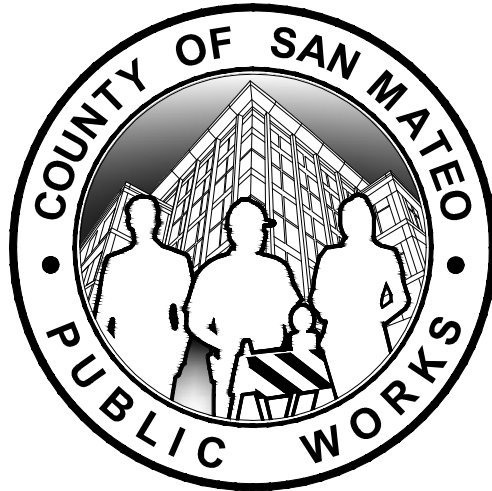

STANDARD DRAWINGS

FOR

PUBLIC IMPROVEMENT

---

**SANITARY  
SEWER  
STANDARDS**

**COUNTY OF SAN MATEO DEPARTMENT  
OF  
PUBLIC WORKS**

DRAWN BY: A.Z.  
 CHECKED BY: K.L.  
 APPROVED BY: A.M.S.

SCALE: NONE  
 DATE: 2-2022  
 REVISED: 2-2022

.....  
 REDWOOD CITY  
 CALIFORNIA

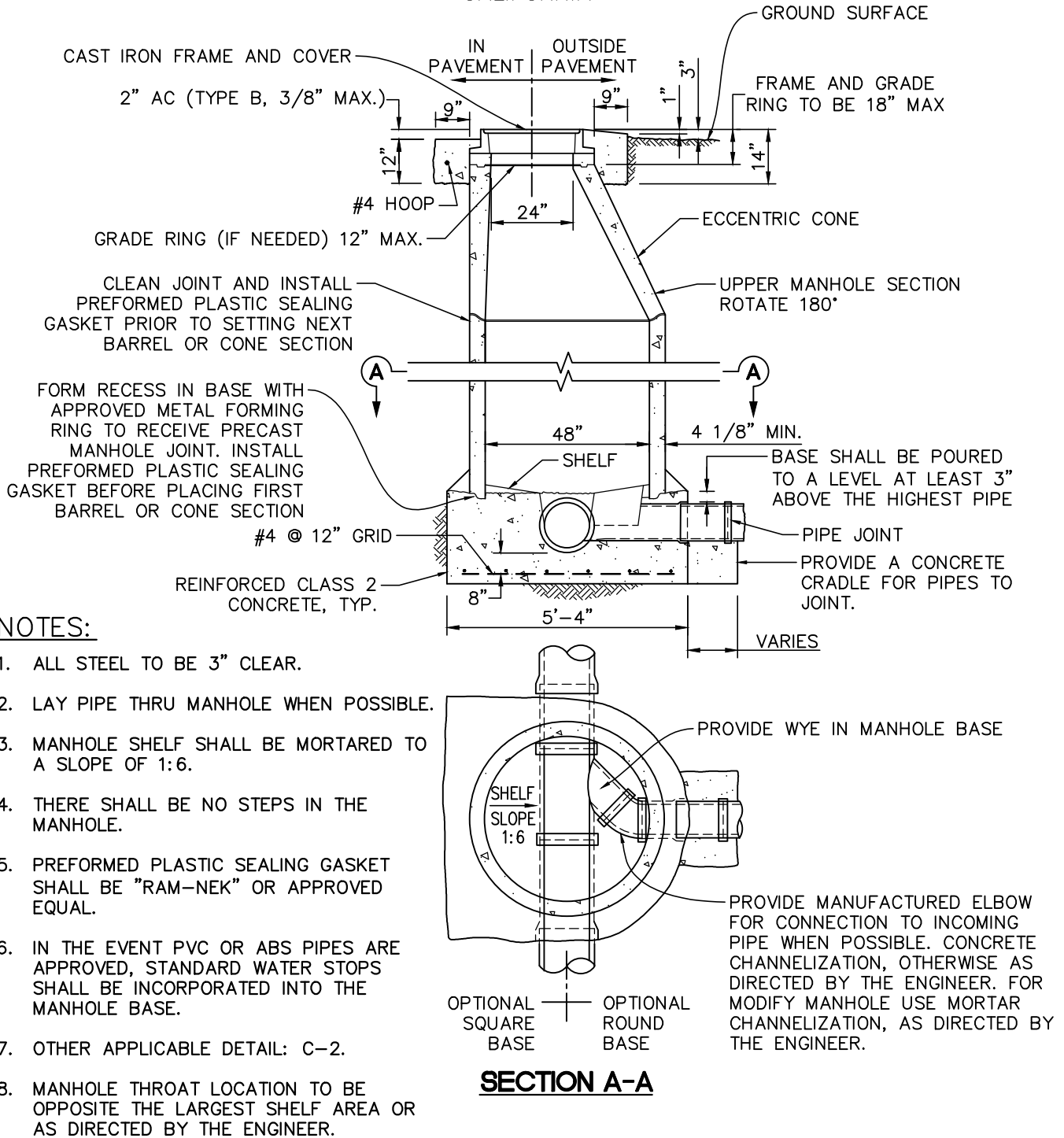

**SANITARY SEWER MANHOLE DETAIL**



**COUNTY OF SAN MATEO DEPARTMENT  
OF**

DRAWN BY: A.Z.  
 CHECKED BY: K.L.  
 APPROVED BY: A.M.S.

**PUBLIC WORKS**

.....  
 REDWOOD CITY  
 CALIFORNIA

SCALE: NONE  
 DATE: 2-2022  
 REVISED: 2-2022

GENERAL NOTE:

FRAME AND COVER SHALL MEET OR EXCEED THE REQUIREMENTS OF AASHTO H-20 LOADING.

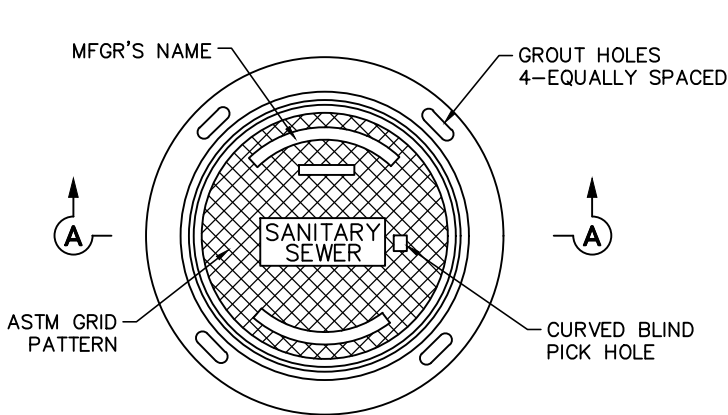

\* ALL MATERIALS USED SHALL CONFORM TO ASTM SPEC. A-159-70T-G3000 OR U.S. GOV'T SPEC. QQ1-653

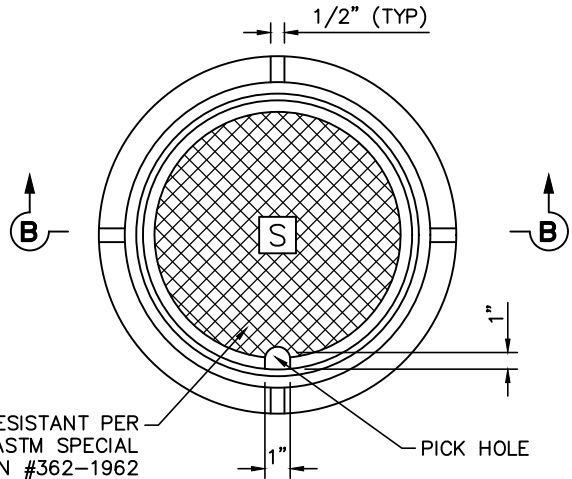

\* ALL MATERIALS USED SHALL CONFORM TO ASTM SPEC. A-159-64T-G3000 OR U.S. GOV'T SPEC. QQ1-653

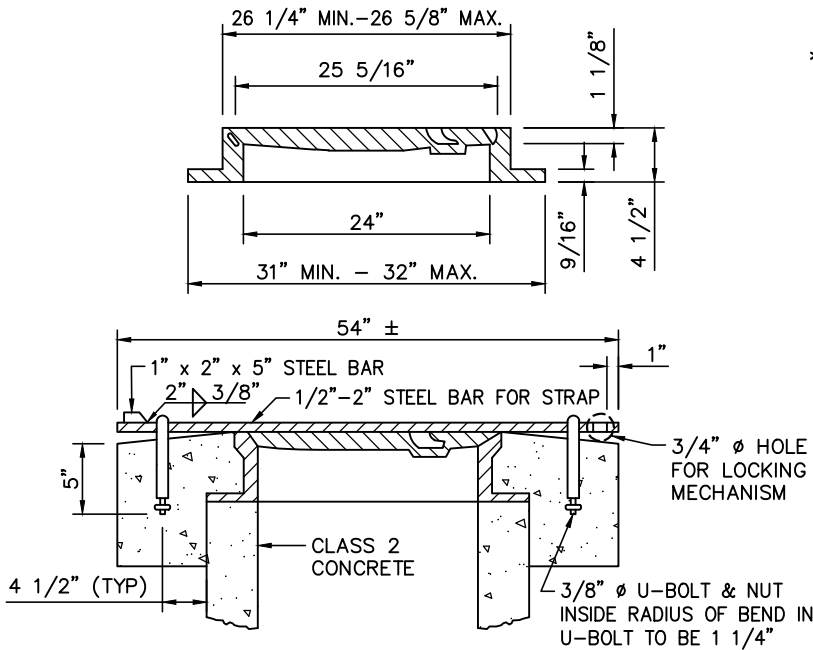

\* MANHOLE STRAP TO BE USED IN OFF ROAD AREA WHERE SPECIFIED BY THE ENGINEER  
 \* U-BOLTS, NUT & STRAP SHALL BE HOT DIP GALVANIZED AFTER FABRICATION

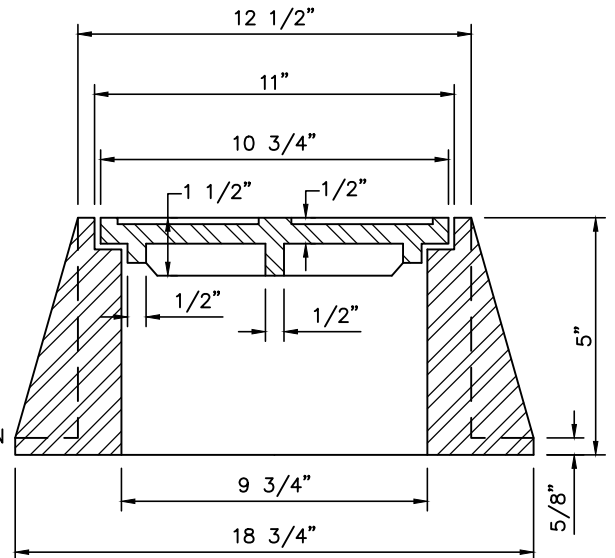

**SECTION A-A**

**SECTION B-B**

**SANITARY SEWER MANHOLE  
 COVER, FRAME AND STRAP  
 DETAIL**

**SANITARY SEWER  
 FLUSHING INLET  
 COVER**

**COUNTY OF SAN MATEO DEPARTMENT  
OF  
PUBLIC WORKS**

DRAWN BY: A.Z.  
CHECKED BY: K.L.  
APPROVED BY: A.M.S.

SCALE: NONE  
DATE: 2-2022  
REVISED: 2-2022

.....  
REDWOOD CITY  
CALIFORNIA

CLEANOUT BOX TO BE INSTALLED WITHIN 5' OF PROPERTY LINE, AND REMAIN 5' CLEAR OF ANY OBSTRUCTIONS.

BRASS CLEANOUT PLUG (ALL PIPE TYPES)

WYE & RISER TO BE THE SAME PIPE MATERIAL AS THE DISTRICT MAINTAINED PORTION OF THE LATERAL, EXCEPT THAT THE UPPER-MOST 3 FEET OF A VCP RISER SHALL BE CAST IRON.

CHRISTY CONCRETE TYPE B3 METER BOX WITH DIO LID, OR BROOKS PRODUCTS NO. 3. STANDARD METER BOX BODY WITH LIGHT CONCRETE COVER, OR EQUAL.

BANDED RUBBER COUPLING

TRANSITION SECTION IF NEEDED

**TYPICAL CLEANOUT  
DETAIL**

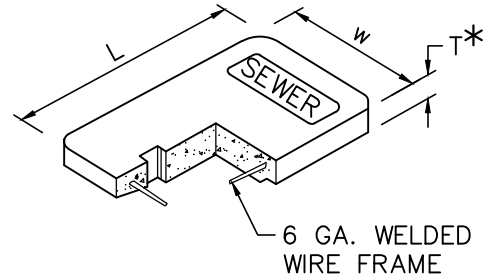
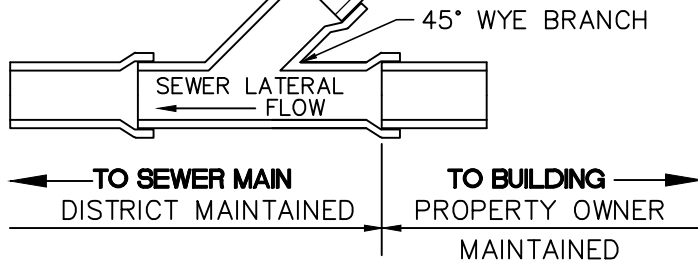

**DIMENSIONAL SKETCH**

**LID DIMENSIONS**

	L	W	T	APPROX WT. (LBS.)
CHRISTY DIO	14 1/2"	8 11/16"	11/16"	7
BROOKS #3 NS	14 1/2"	8 3/4"	1"	13

\*PROVIDE STEEL TRAFFIC COVER FOR BOX WHEN INSTALLED IN LOCATION SUBJECT TO VEHICULAR LOADING

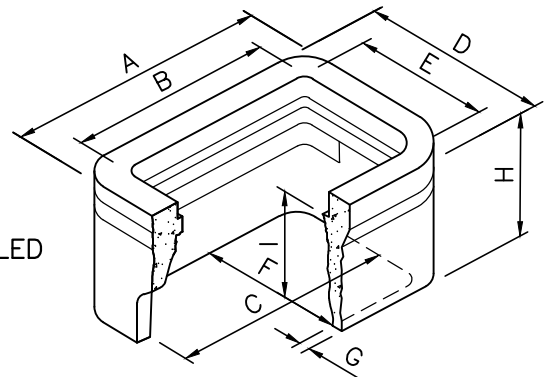

**BOX DIMENSIONS**

	A	B	C	D	E	F	G	H	I	APPROX WT. (LBS.)
CHRISTY B3	19"	14 13/16"	16 1/4"	13 1/4"	9"	9 7/8"	1"	12"	10 15/16"	59
BROOKS #3	19 1/8"	13 1/2"	16"	13 1/4"	7 5/8"	9 1/2"	1"	11"	N.A.	68

**TYPICAL SEWER  
CLEANOUT BOX**

COUNTY OF SAN MATEO DEPARTMENT  
OF

PUBLIC WORKS

.....  
REDWOOD CITY  
CALIFORNIA

DRAWN BY: A.Z.  
CHECKED BY: K.L.  
APPROVED BY: A.M.S.

SCALE: NONE  
DATE: 2-2022  
REVISED: 2-2022

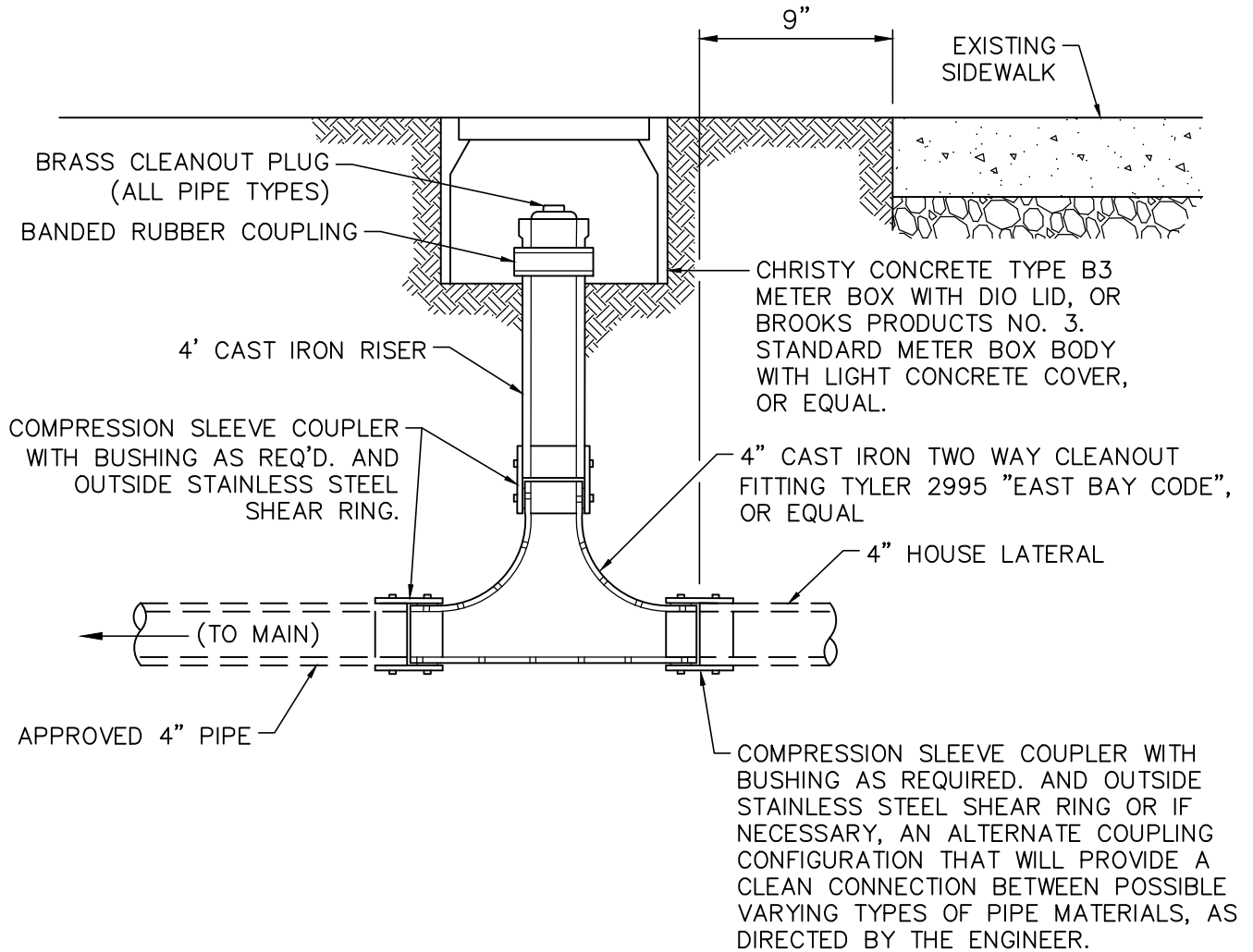

\* NOTE: ALTERNATE CLEANOUT TO BE USED ONLY WHEN PERMITTED BY UTILITY MANAGER.

ALTERNATE CLEANOUT  
DETAIL

**COUNTY OF SAN MATEO DEPARTMENT  
OF**

**PUBLIC WORKS**

.....  
REDWOOD CITY  
CALIFORNIA

DRAWN BY: A.Z.  
CHECKED BY: K.L.  
APPROVED BY: A.M.S.

SCALE: NONE  
DATE: 2-2022  
REVISED: 2-2022

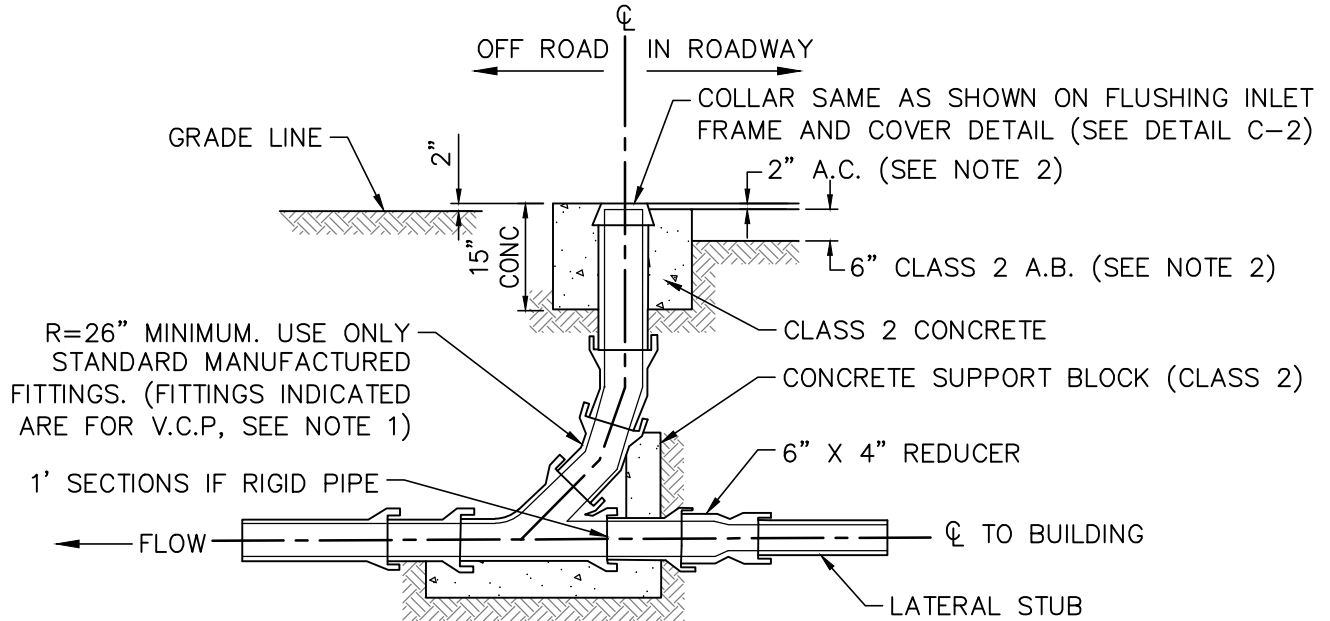

**FLUSHING INLET WITH LATERAL STUB**

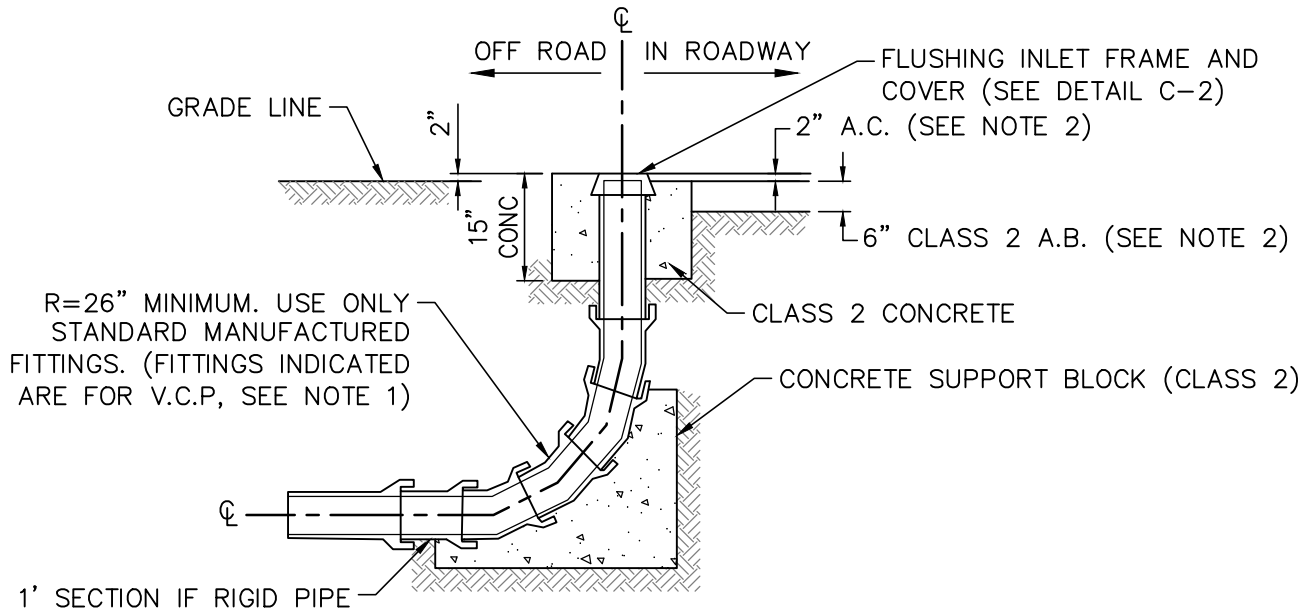

**NOTES:**

1. FOR P.V.C. PIPE, LARGE 90° MANUFACTURED SWEEPS MAY BE USED IF R=36" OR GREATER.
2. MINIMUM STRUCTURAL SECTIONS SHOWN. SEE STANDARD STREET SECTION DETAILS.

**FLUSHING INLET**  
**SANITARY SEWER FLUSHING INLET DETAIL**

**COUNTY OF SAN MATEO DEPARTMENT  
OF**

DRAWN BY: A.Z.  
 CHECKED BY: K.L.  
 APPROVED BY: A.M.S.

**PUBLIC WORKS**

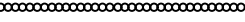

REDWOOD CITY  
CALIFORNIA

SCALE: NONE  
 DATE: 2-2022  
 REVISED: 2-2022

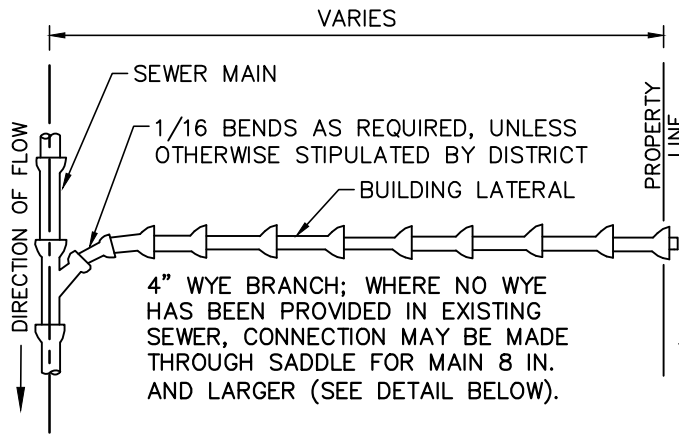

ON NEW CONSTRUCTION—LATERAL TO BE PLACED 5' ABOVE LOWER LOT LINE UNLESS OTHERWISE DIRECTED BY THE ENGINEER. THE WYE LATERAL AND PROPERTY LINE CLEAN OUT SHALL BE OF THE SAME MATERIAL

5'-0" LOWER LOT LINE IN RELATION TO SEWER FLOW

**PLAN**

- NOTES: (1) SEE DETAILS C-3A AND C-3B FOR SAN MATEO COUNTY STANDARD CLEANOUT DETAIL.  
 (2) BEDDING AND BACKFILL MATERIAL SEE DETAILS C-6 (TYPE A OR B) OR C-7.

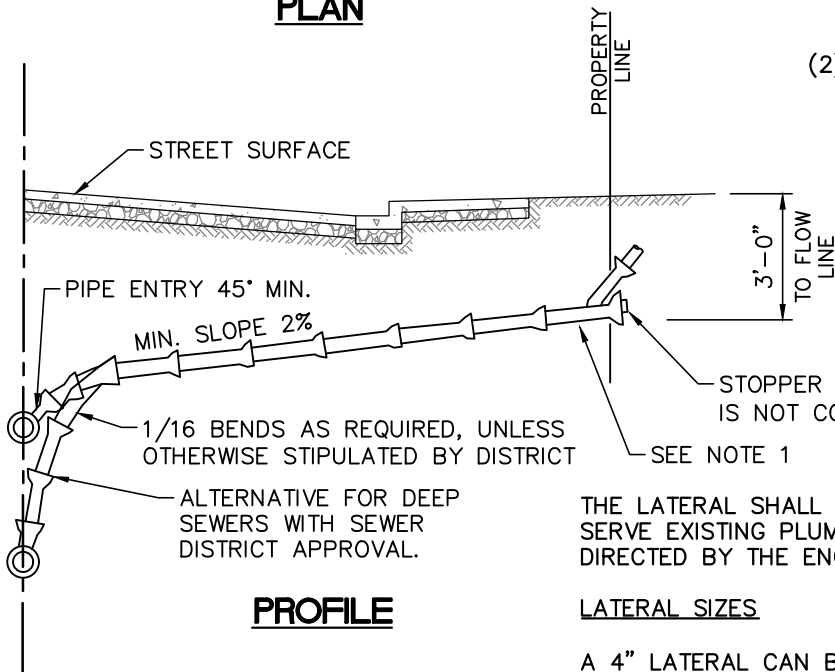

THE LATERAL SHALL BE LOWER WHERE NECESSARY TO SERVE EXISTING PLUMBING OR LOW LOTS OR WHEN DIRECTED BY THE ENGINEER.

**PROFILE**

**LATERAL SIZES**

A 4" LATERAL CAN BE USED FOR A SINGLE FAMILY RESIDENCE OR A SFR WITH A SECOND UNIT. A MINIMUM 6" LATERAL SHALL BE USED FOR ALL OTHER DEVELOPMENTS.

**METHOD OF ATTACHING LATERAL TO EXISTING SEWER WHERE NO WYE HAS BEEN PROVIDED**

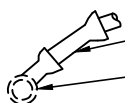

1/16 BENDS AS REQUIRED

1. EXISTING MAIN  $\leq 8"$ : FOR MEANS BY WHICH CONNECTION IS TO BE MADE TO MAIN LINE SEE DETAIL C-8.
2. EXISTING MAIN 10"-18": CONNECTION BY MEANS OF AN APPROVED SADDLE "TEE."
3. EXISTING MAIN  $> 18"$ : CONNECTION SHALL BE AT A MANHOLE UNLESS OTHERWISE APPROVED BY THE SEWER DISTRICT.

**SEWER LATERAL DETAIL**

**COUNTY OF SAN MATEO DEPARTMENT  
OF**

**PUBLIC WORKS**

.....  
REDWOOD CITY  
CALIFORNIA

DRAWN BY: A.Z.  
CHECKED BY: K.L.  
APPROVED BY: A.M.S.

SCALE: NONE  
DATE: 2-2022  
REVISED: 2-2022

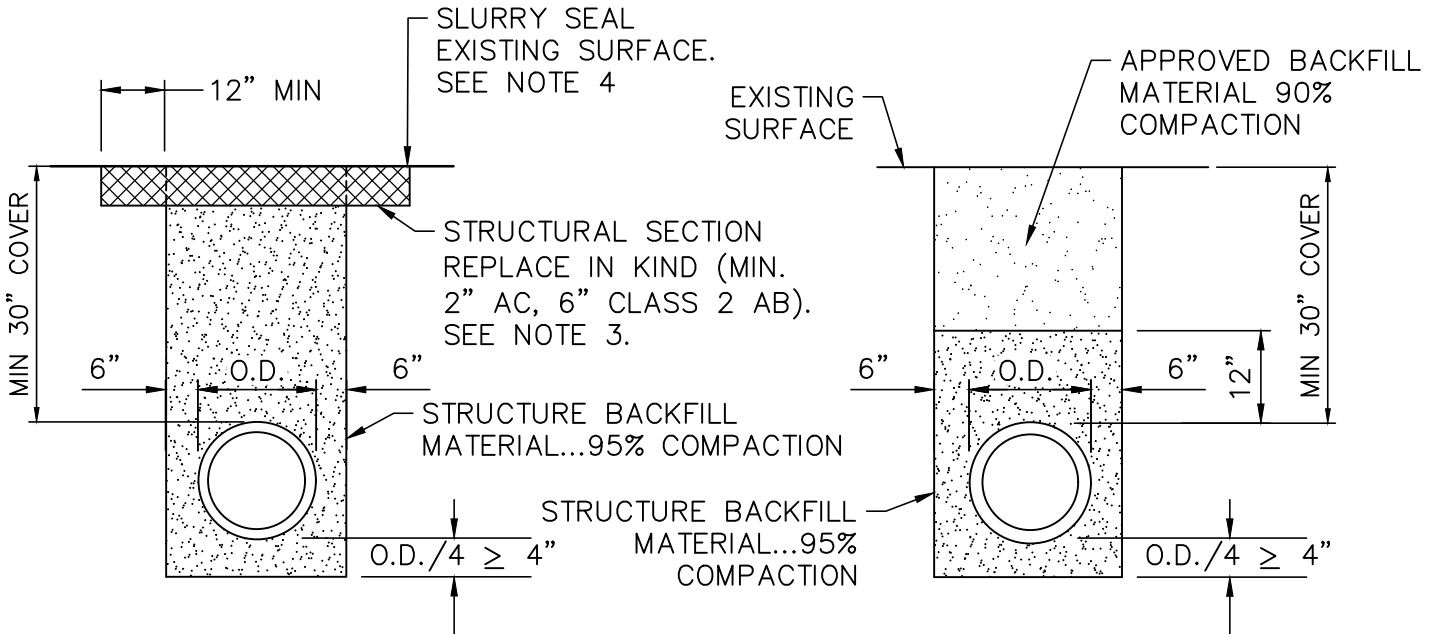

**TYPE A (IN ROADWAY)**

**TYPE B (OUTSIDE ROADWAY)**

**NOTES:**

1. STRUCTURE BACKFILL MATERIAL....MATERIAL WITH SAND EQUIVALENT NOT LESS THAN 20 AND SIEVE GRADATION BY WEIGHT AS FOLLOWS:

<u>SIEVE SIZE</u>	<u>% PASSING SIEVE</u>
3"	100
No. 4	35-100
No. 200	20-100

2. BACKFILL MATERIAL.... MATERIAL FROM EXCAVATION, FREE FROM STONES OR LUMPS EXCEEDING 3 INCHES GREATEST DIMENSION, ORGANIC MATTER, OR OTHER UNSATISFACTORY MATERIAL.
3. ON TRENCHES THAT PARALLEL THE ROAD AND ARE WITHIN EXISTING BICYCLE LANES, THE WIDTH OF THE STRUCTURAL SECTION SHALL BE GREATER THAN OR EQUAL TO THE WIDTH OF THE EXISTING BICYCLE LANE, WHICHEVER IS WIDER. PAVING JOINTS WITHIN BICYCLE LANE ARE NOT ALLOWED.
4. FULL WIDTH SLURRY SHALL BE APPLIED TO THE FINISH SURFACE FROM EDGE OF PAVEMENT TO EDGE OF PAVEMENT WHEN THERE IS A MAIN OR LATERAL LINE INSTALLATION THAT IS GREATER THAN 100 FEET IN TOTAL LENGTH. SLURRY SEAL SHALL COMPLY WITH CALTRANS STANDARD SPECIFICATIONS. SPREAD RATE TO BE 17 LBS/SY (±1).

**STANDARD TRENCH BACKFILL AND BEDDING DETAIL  
FOR VITRIFIED CLAY AND DUCTILE IRON SEWER PIPE**

**COUNTY OF SAN MATEO DEPARTMENT  
OF**

DRAWN BY: A.Z.  
 CHECKED BY: K.L.  
 APPROVED BY: A.M.S.

**PUBLIC WORKS**



REDWOOD CITY  
CALIFORNIA

SCALE: NONE  
 DATE: 2-2022  
 REVISED: 2-2022

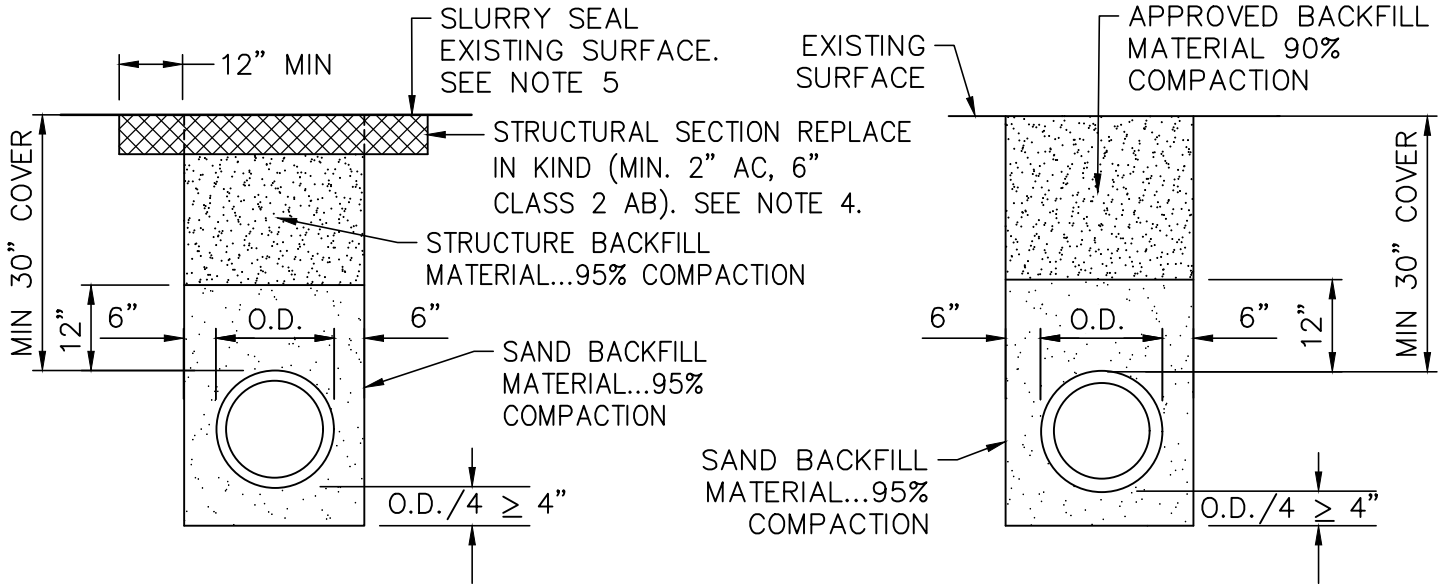

**TYPE A (IN ROADWAY)**

**TYPE B (OUTSIDE ROADWAY)**

**NOTES:**

- SAND...MATERIAL FREE FROM ORGANIC MATTER AND CLAY WITH A SIEVE GRADATION BY WEIGHT AS FOLLOWS:
 

SIEVE SIZE	% PASSING SIEVE
No. 4	100
No. 200	0-5
- STRUCTURE BACKFILL MATERIAL...MATERIAL WITH SAND EQUIVALENT NOT LESS THAN 20 AND SIEVE GRADATION BY WEIGHT AS FOLLOWS:
 

SIEVE SIZE	% PASSING SIEVE
3"	100
No. 4	35-100
No. 200	20-100
- BACKFILL MATERIAL.... MATERIAL FROM EXCAVATION, FREE FROM STONES OR LUMPS EXCEEDING 3 INCHES GREATEST DIMENSION, ORGANIC MATTER, OR OTHER UNSATISFACTORY MATERIAL.
- ON TRENCHES THAT PARALLEL THE ROAD AND ARE WITHIN EXISTING BICYCLE LANES, THE WIDTH OF THE STRUCTURAL SECTION SHALL BE GREATER THAN OR EQUAL TO THE WIDTH OF THE EXISTING BICYCLE LANE. PAVING JOINTS WITHIN BICYCLE LANE ARE NOT ALLOWED.
- FULL WIDTH SLURRY SHALL BE APPLIED TO THE FINISH SURFACE FROM EDGE OF PAVEMENT TO EDGE OF PAVEMENT WHEN THERE IS A MAIN OR LATERAL LINE INSTALLATION THAT IS GREATER THAN 100 FEET IN TOTAL LENGTH. SLURRY SEAL SHALL COMPLY WITH CALTRANS STANDARD SPECIFICATIONS. SPREAD RATE TO BE 17 LBS/SY (±1).

**STANDARD TRENCH BACKFILL AND BEDDING DETAIL  
FOR PVC SEWER PIPE**

**COUNTY OF SAN MATEO DEPARTMENT  
OF**

**PUBLIC WORKS**

.....  
REDWOOD CITY  
CALIFORNIA

DRAWN BY: A.Z.  
CHECKED BY: K.L.  
APPROVED BY: A.M.S.

SCALE: NONE  
DATE: 2-2022  
REVISED: 2-2022

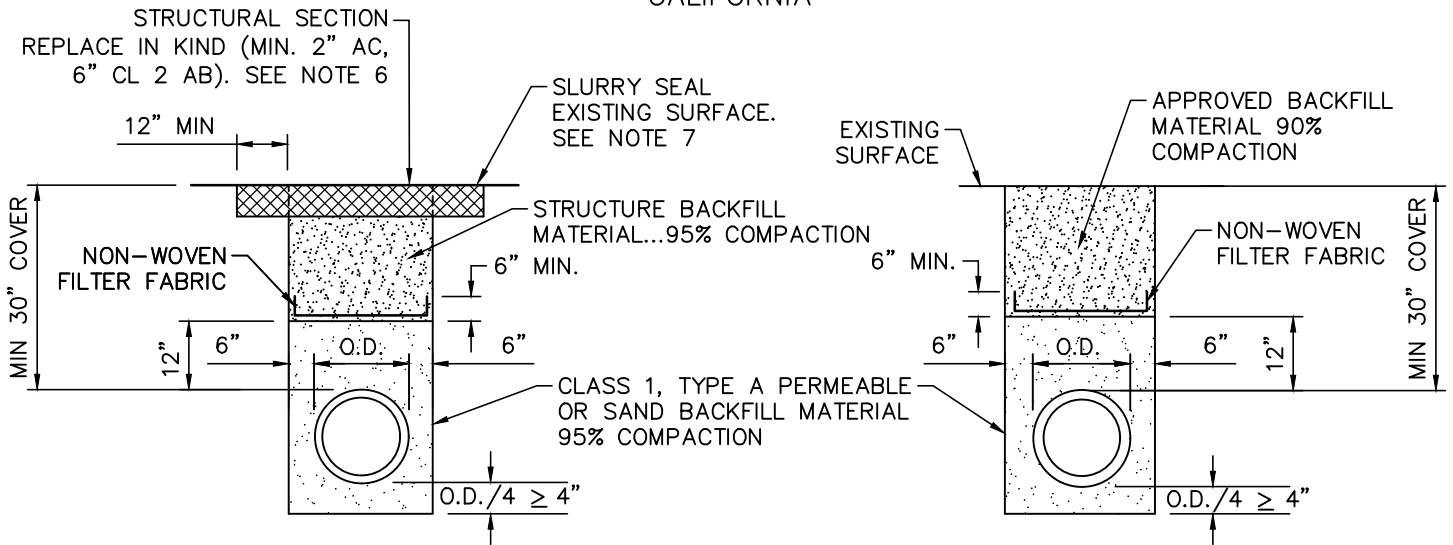

**TYPE A (IN ROADWAY OR SIDEWALK)      TYPE B (OUTSIDE ROADWAY)**

**NOTES:**

- SAND....MATERIAL FREE FROM ORGANIC MATTER AND CLAY WITH A SIEVE GRADATION BY WEIGHT AS FOLLOWS:
 

SIEVE SIZE	% PASSING SIEVE
No. 4	100
No. 200	0-5
- STRUCTURE BACKFILL MATERIAL....MATERIAL WITH SAND EQUIVALENT NOT LESS THAN 20 AND SIEVE GRADATION BY WEIGHT AS FOLLOWS:
 

SIEVE SIZE	% PASSING SIEVE
3"	100
No. 4	35-100
No. 200	20-100
- BACKFILL MATERIAL.... MATERIAL FROM EXCAVATION, FREE FROM STONES OR LUMPS EXCEEDING 3 INCHES GREATEST DIMENSION, ORGANIC MATTER, OR OTHER UNSATISFACTORY MATERIAL.
- IF PERMEABLE BACKFILL USED IN PIPE ZONE, NON-WOVEN FILTER FABRIC SHALL BE PLACED AS SHOWN PRIOR TO BACKFILLING ABOVE PIPE ZONE. FILTER FABRIC JOINTS SHALL BE LAPPED 6" LONGITUDINALLY.
- FOR INSTALLATIONS UNDER SIDEWALK SAWCUTS SHALL OCCUR AT SCORE MARKS OR CONSTRUCTION JOINTS. WHERE SERVICE LINE IS LOCATED WITHIN 6" OF SCORE LINE OR JOINTS, 2 SECTIONS OF SIDEWALK SHALL BE SAWCUT AND REPLACED IN KIND.
- ON TRENCHES THAT PARALLEL THE ROAD AND ARE WITHIN EXISTING BICYCLE LANES, THE WIDTH OF THE STRUCTURAL SECTION SHALL BE GREATER THAN OR EQUAL TO THE WIDTH OF THE EXISTING BICYCLE LANE. PAVING JOINTS WITHIN BICYCLE LANE ARE NOT ALLOWED.
- FULL WIDTH SLURRY SHALL BE APPLIED TO THE FINISH SURFACE FROM EDGE OF PAVEMENT TO EDGE OF PAVEMENT WHEN THERE IS A MAIN OR LATERAL LINE INSTALLATION THAT IS GREATER THAN 100 FEET IN TOTAL LENGTH. SLURRY SEAL SHALL COMPLY WITH CALTRANS STANDARD SPECIFICATIONS. SPREAD RATE TO BE 17 LBS/SY (±1).

**STANDARD TRENCH BACKFILL AND BEDDING DETAIL**  
**FOR WEST BAY SANITARY SEWER INSTALLATIONS**



**COUNTY OF SAN MATEO DEPARTMENT  
OF**

DRAWN BY: A.Z.  
 CHECKED BY: K.L.  
 APPROVED BY: A.M.S.

**PUBLIC WORKS**

.....  
 REDWOOD CITY  
 CALIFORNIA

SCALE: NONE  
 DATE: 2-2022  
 REVISED: 2-2022

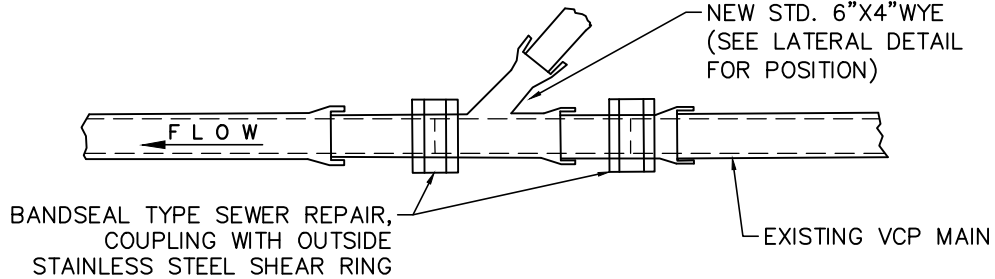

**NOTE:** THE NEWLY INSTALLED WYE SHALL BE OF THE SAME MATERIAL AS THE EXISTING MAIN.

**PLAN  
VITRIFIED CLAY PIPE (VCP)**

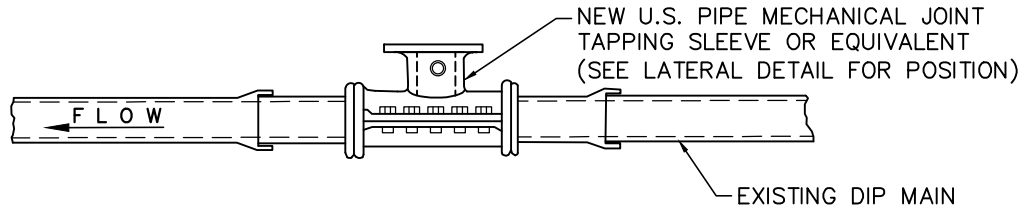

**NOTE:** HORIZONTAL PIPE ENTRY ANGLE WILL BE 90° INSTEAD OF 45° (SEE LATERAL DETAIL, PLAN VIEW).  
 VERTICAL PIPE ENTRY ANGLE SHALL BE 45° MINIMUM (SEE LATERAL DETAIL, PROFILE VIEW).

**PLAN  
DUCTILE IRON PIPE (DIP)**

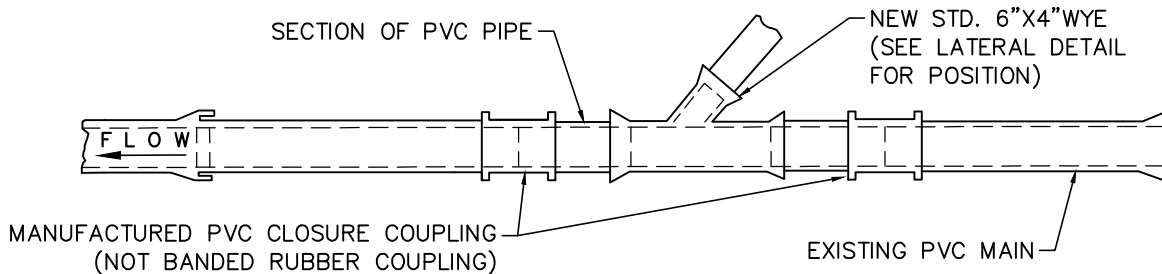

**NOTE:** ALL PVC, PIPE AND FITTINGS SHALL BE SDR 35 AND SHALL HAVE RUBBER GASKETED JOINTS.  
 SOLVENT WELDED JOINTS SHALL NOT BE ALLOWED

**PLAN  
POLYVINYL CHLORIDE (PVC) PIPE**

**LATERAL CONNECTION INSTALLATION DETAIL ON EXISTING PIPE**

**NOTE:** LATERAL CONNECTION INSTALLATION ON NEWLY INSTALLED PIPE WILL BE  
 AS DIRECTED BY THE DEPARTMENT OF PUBLIC WORKS.

**COUNTY OF SAN MATEO DEPARTMENT  
OF**

**PUBLIC WORKS**

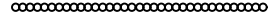

REDWOOD CITY  
CALIFORNIA

DRAWN BY: A.Z.  
CHECKED BY: K.L.  
APPROVED BY: A.M.S.

SCALE: NONE  
DATE: 2-2022  
REVISED: 2-2022

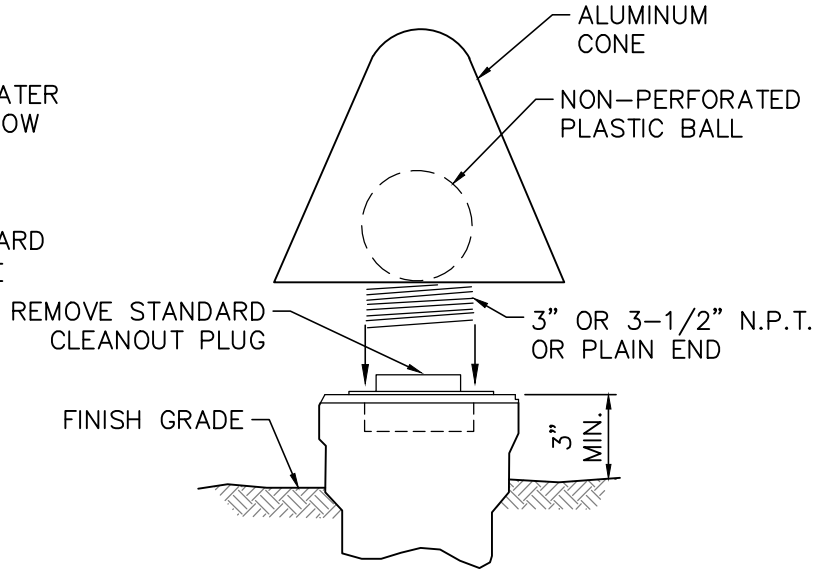
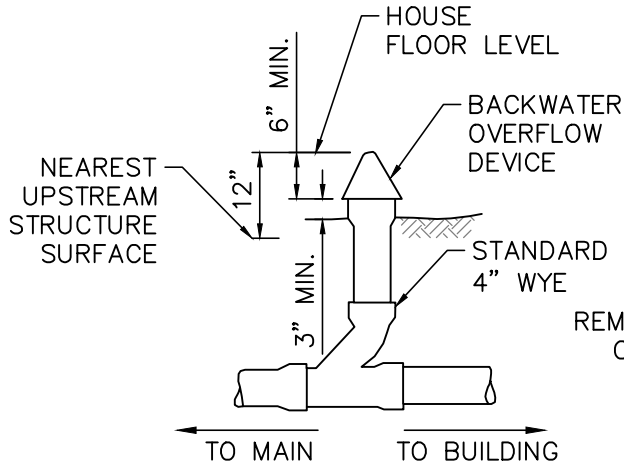

**NOTE:**  
LOCATION OF DEVICE TO APPROVAL  
OF DISTRICT AND BUILDING  
DEPARTMENT PRIOR TO INSTALLATION

**OVERFLOW DEVICE**

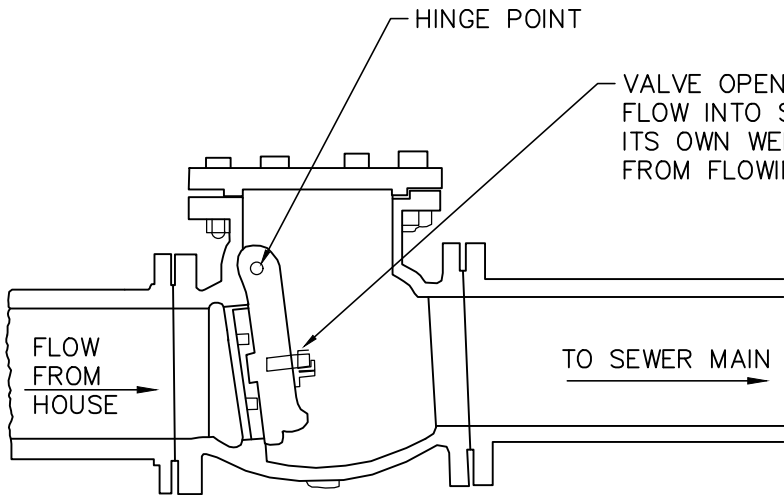

VALVE OPENS TO ALLOW WASTE WATER TO  
FLOW INTO SEWER MAIN; VALVE CLOSES BY  
ITS OWN WEIGHT TO PREVENT WASTEWATER  
FROM FLOWING BACK TO HOUSE LATERAL.

**NOTE:**  
LOCATION OF DEVICE TO  
APPROVAL OF DISTRICT AND  
BUILDING DEPARTMENT PRIOR  
TO INSTALLATION

**BACKFLOW DEVICE**

**OVERFLOW AND BACKFLOW DEVICE DETAIL**

**COUNTY OF SAN MATEO DEPARTMENT  
OF**

DRAWN BY: A.Z.  
 CHECKED BY: K.L.  
 APPROVED BY: A.M.S.

**PUBLIC WORKS**



REDWOOD CITY  
CALIFORNIA

SCALE: NONE  
 DATE: 2-2022  
 REVISED: 2-2022

**NOTICE:**

CALL SANITARY DISTRICT (650-363-4765 OR 650-363-4100) BEFORE MAKING ANY SEWER REPAIRS. ALL REPAIRS MUST BE DONE IN THE PRESENCE OF A DISTRICT INSPECTOR.

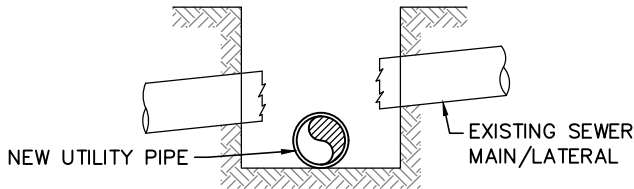

SIMPLE SEWER MAIN/LATERAL BREAK  
(NO CONFLICT IN GRADE)

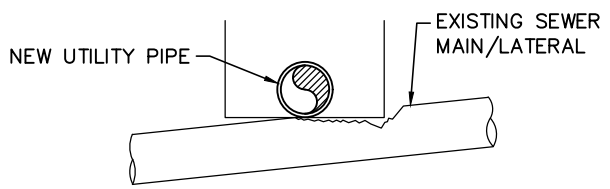

SIMPLE SEWER MAIN/LATERAL BREAK  
(NO CONFLICT IN GRADE)

**BREAK**

**BREAK**

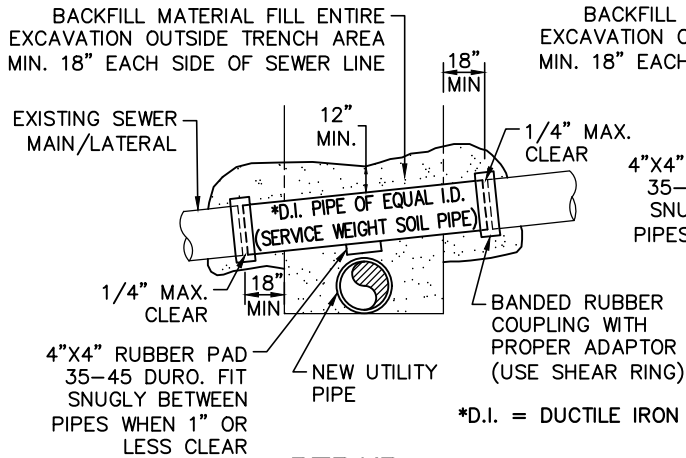

**REPAIR**

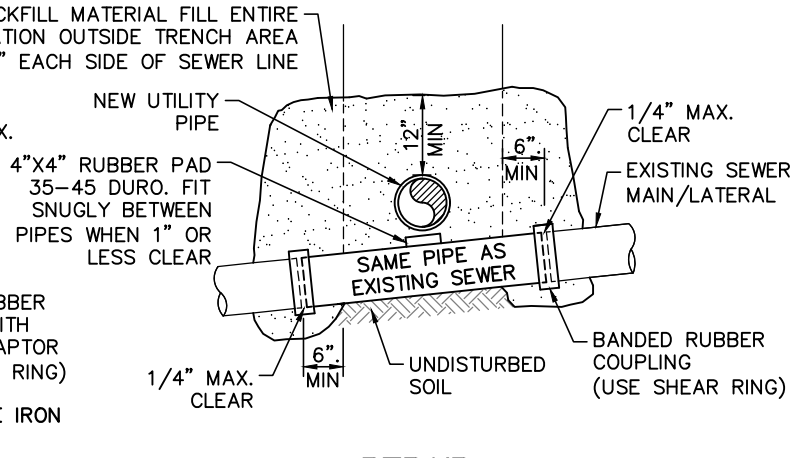

**REPAIR**

**PROCEDURE:**

**PROCEDURE:**

1. NOTIFY SANITARY DISTRICT (650-363-4765 OR 650-363-4100).
2. TRIM SEWER PIPE TO A CLEAN CUT UNDAMAGED END, A MINIMUM OF 18" INTO TRENCH WALL. CUT PIECE OF NEW DUCTILE IRON PIPE (D.I.P.) OF EQUAL DIAMETER TO FIT SPACE BETWEEN TRIMMED ENDS WITH A MAXIMUM CLEARANCE OF 1/4 INCH AT EACH END. ALIGN PIPES AT UPSTREAM END AND SLIDE COUPLING DOWNSTREAM, CENTERING IT OVER THE JOINT, TIGHTEN COUPLING BANDS. WHEN O.D. OF PIPES ARE WITHIN 1" OF EACH OTHER, THERE SHALL BE A 4"X4" PAD OF 35-45 DUROMETER RUBBER PLACED SNUGLY BETWEEN THE PIPES.
3. CONCRETE ENCASEMENT SHALL BE REQUIRED IN THE EVENT THE ADJACENT SOIL IS DISTURBED. LIMITS SHALL BE DETERMINED BY THE DISTRICT.

1. NOTIFY SANITARY DISTRICT (650-363-4765 OR 650-363-4100)
2. REPAIR SHALL BE MADE AS SHOWN ABOVE WHEN CLEARANCE BETWEEN SEWER PIPE AND UTILITY PIPE IS 6" OR MORE, REPAIR MAY BE MADE WITH THE SAME TYPE OF PIPE AS THE EXISTING SEWER. WHEN O.D. OF PIPES ARE WITHIN 1" OF EACH OTHER, THERE SHALL BE A 4" X 4" PAD OF 35-45 DUROMETER RUBBER PLACED SNUGLY BETWEEN THE PIPES.
3. IF EXISTING SEWER PIPE IS PVC OR ABS, USE MANUFACTURED COUPLINGS AND NOT BANDED RUBBER COUPLINGS.
4. CONCRETE ENCASEMENT SHALL BE REQUIRED IN THE EVENT THE ADJACENT SOIL IS DISTURBED. LIMITS SHALL BE DETERMINED BY THE DISTRICT.

**VITRIFIED CLAY AND DUCTILE IRON SEWER PIPES  
PIPE CROSSING REPAIR DETAIL**

**COUNTY OF SAN MATEO DEPARTMENT  
OF**

DRAWN BY: A.Z.  
 CHECKED BY: K.L.  
 APPROVED BY: A.M.S.

**PUBLIC WORKS**



REDWOOD CITY  
CALIFORNIA

SCALE: NONE  
 DATE: 2-2022  
 REVISED: 2-2022

**NOTICE:**

CALL SANITARY DISTRICT (650-363-4765 OR 650-363-4100) BEFORE MAKING ANY SEWER REPAIRS.  
 ALL REPAIRS MUST BE DONE IN THE PRESENCE OF A DISTRICT INSPECTOR.

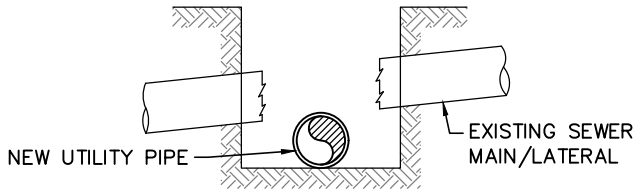

**SIMPLE SEWER MAIN/LATERAL BREAK  
(NO CONFLICT IN GRADE)**

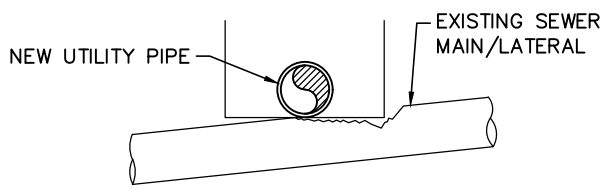

**SIMPLE SEWER MAIN/LATERAL BREAK  
(NO CONFLICT IN GRADE)**

**BREAK**

BACKFILL MATERIAL (SEE NOTE 1),  
 FILL ENTIRE EXCAVATION OUTSIDE  
 TRENCH AREA MIN. 18" EACH SIDE  
 OF SEWER LINE

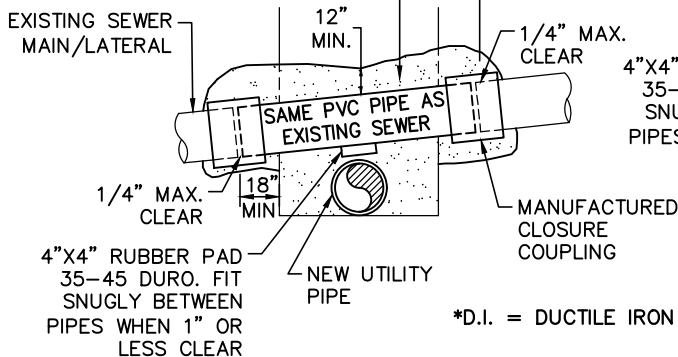

**REPAIR**

\*D.I. = DUCTILE IRON

**BREAK**

BACKFILL MATERIAL (SEE NOTE 1),  
 FILL ENTIRE EXCAVATION OUTSIDE  
 TRENCH AREA MIN. 18" EACH SIDE  
 OF SEWER LINE

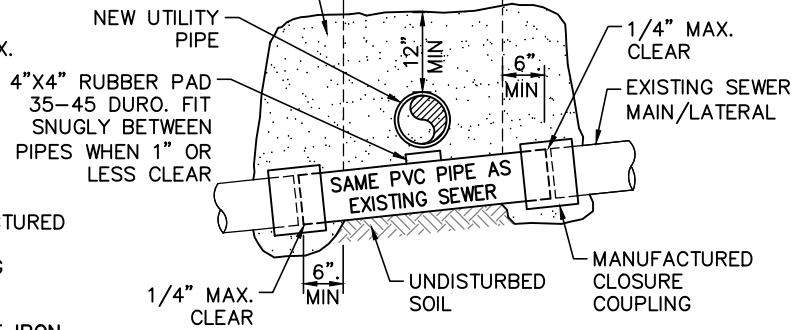

**REPAIR**

**NOTES:**

- BACKFILL MATERIAL SHALL BE SAND AS SPECIFIED IN STANDARD TRENCH BACKFILL AND BEDDING DETAIL FOR P.V.C. SEWER PIPE (C-7) OR OTHER MATERIAL APPROVED EQUAL BY THE SEWER DIVISION.
- THE USE OF BANDED RUBBER COUPLINGS IS PROHIBITED.

**PROCEDURE:**

- NOTIFY SANITARY DISTRICT (650-363-4765 OR 650-363-4100).
- TRIM SEWER MAIN/LATERAL TO A CLEAN-CUT, UNDATED END, A MINIMUM OF 18" INTO TRENCH WALL. INSTALL NEW PVC PIPE WITH MANUFACTURED CLOSURE COUPLINGS (IN ACCORDANCE WITH MANUFACTURER'S INSTRUCTIONS).
- WHEN OUTSIDE DIAMETER OF THE CROSSING PIPES ARE WITHIN 1" OF EACH OTHER, THERE SHALL BE A 4" X 4" PAD OF 35-45 DUROMETER RUBBER PLACED SNUGLY BETWEEN THE PIPES.

**PROCEDURE:**

- NOTIFY SANITARY DISTRICT (650-363-4765 OR 650-363-4100)
- WHEN O.D. OF PIPES ARE WITHIN 1" OF EACH OTHER, THERE SHALL BE A 4" X 4" PAD OF 35-45 DUROMETER RUBBER PLACED SNUGLY BETWEEN THE PIPES.

**POLYVINYL CHLORIDE (PVC) SEWER PIPE  
PIPE CROSSING REPAIR DETAIL**

**COUNTY OF SAN MATEO DEPARTMENT  
OF  
PUBLIC WORKS**

DRAWN BY: A.Z.  
 CHECKED BY: K.L.  
 APPROVED BY: A.M.S.

.....  
 REDWOOD CITY  
 CALIFORNIA

SCALE: NONE  
 DATE: 2-2022  
 REVISED: 2-2022

**NOTES:**

1. LONGITUDINAL TRENCH SLAB REINFORCING: #4 BARS AT 10" O.C. TRANSVERSE TRENCH SLAB REINFORCING: 1-#4 EVERY 20" OF SLAB LENGTH.
2. CONCRETE CAPS SHALL NOT BE USED OVER PLASTIC PIPE.

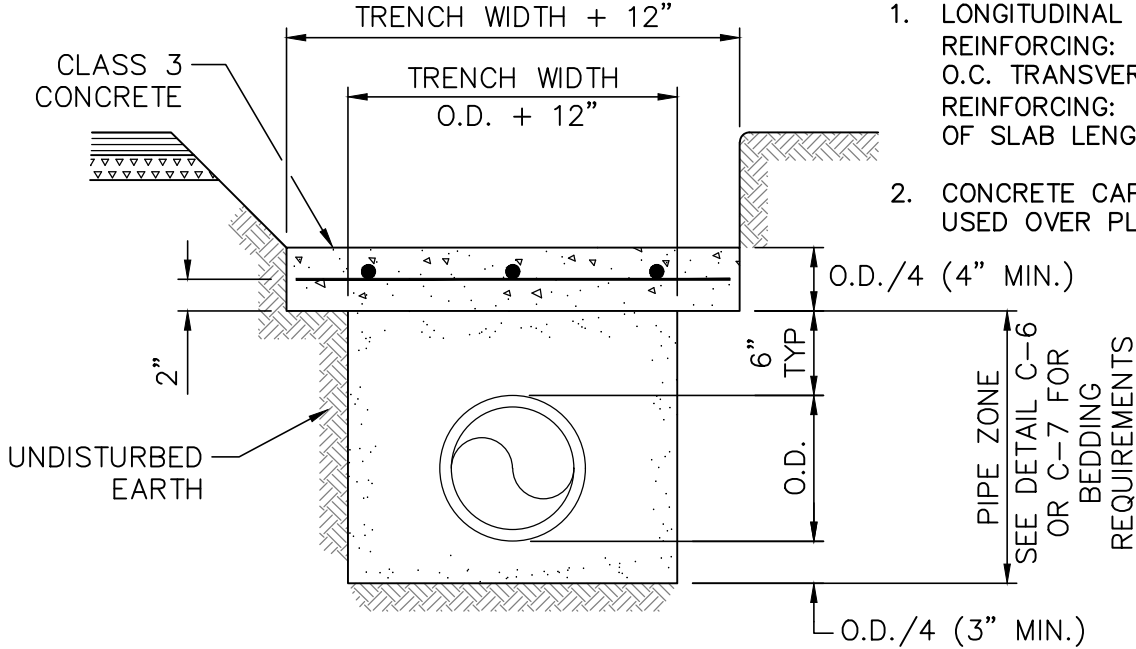

**REINFORCED CONCRETE CAP  
(NON-PLASTIC PIPE ONLY)**

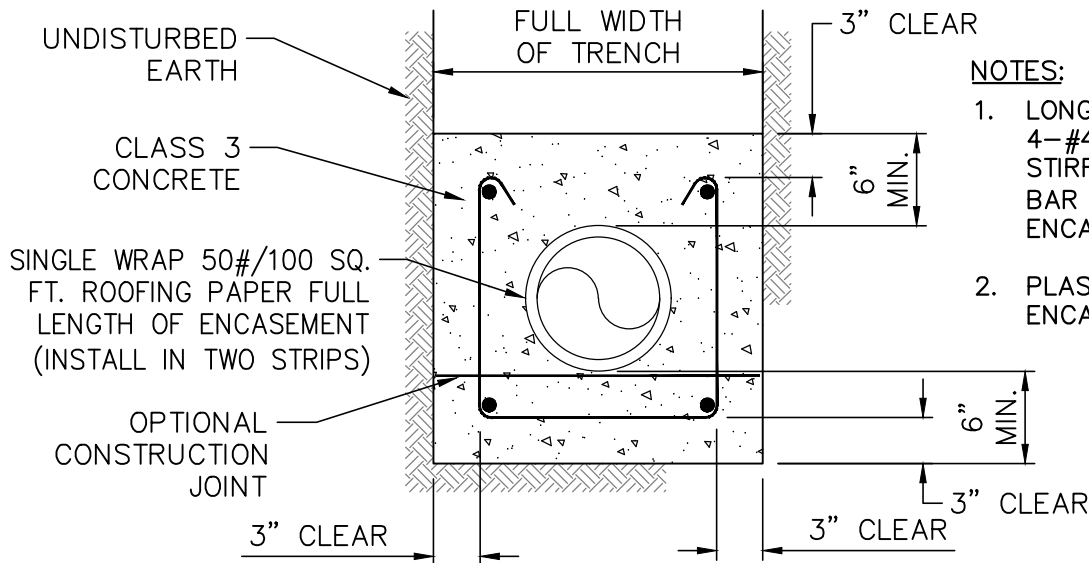

**NOTES:**

1. LONGITUDINAL REINFORCING: 4-#4 BARS AS SHOWN. STIRRUP REINFORCING: 1-#4 BAR EVERY 24" OF CONCRETE ENCASEMENT LENGTH.
2. PLASTIC PIPE SHALL NOT BE ENCASED.

**CONCRETE ENCASEMENT  
(NON-PLASTIC PIPE ONLY)**

**COUNTY OF SAN MATEO DEPARTMENT  
OF**

DRAWN BY: A.Z.  
CHECKED BY: K.L.  
APPROVED BY: A.M.S.

**PUBLIC WORKS**

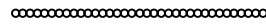

REDWOOD CITY  
CALIFORNIA

SCALE: NONE  
DATE: 2-2022  
REVISED: 2-2022

**SAN MATEO COUNTY SEWER AND SANITATION DISTRICTS  
STANDARD SPECIFICATIONS**

**GENERAL NOTES**

1. ALL REFERENCES TO "DISTRICT" IN THESE GENERAL NOTES SHALL MEAN THE APPROPRIATE COUNTY SEWER OR SANITATION DISTRICT.
2. THE APPROVAL OF THESE PLANS BY THE DISTRICT SHALL BE INTERPRETED TO MEAN THAT THE SANITARY SEWER DESIGN SHOWN ON THESE PLANS MEETS THE DISTRICT'S STANDARDS. THE DISTRICT'S APPROVAL IN NO WAY GUARANTEES ANY OTHER ASPECT OF THIS PLAN OR ITS ACCURACY RELATIVE TO ACTUAL FIELD CONDITIONS.
3. THE CONTRACTOR SHALL CONTACT THE DISTRICT AT 650-363-4765 OR 650-363-4100 TWO (2) WORKING DAYS IN ADVANCE OF BEGINNING ANY SANITARY SEWER WORK. THE CONTRACTOR SHALL THEREAFTER KEEP THE INSPECTOR FOR THE DISTRICT INFORMED OF HIS SCHEDULE FOR SANITARY SEWER WORK.
4. ALL SANITARY SEWER WORK CONSTRUCTED WITHOUT INSPECTION BY THE DISTRICT SHALL BE REMOVED AND RECONSTRUCTED WITH INSPECTION.
5. THE CONTRACTOR SHALL CONTACT UNDERGROUND SERVICE ALERT FORTY-EIGHT (48) HOURS IN ADVANCE OF BEGINNING ANY WORK.
6. THE CONTRACTOR SHALL FIELD VERIFY THE LOCATION OF ALL UTILITIES BEFORE BEGINNING ANY EXCAVATING.
7. THE CONTRACTOR SHALL OBTAIN ANY AND ALL PERMITS REQUIRED BY THE COUNTY OR CITY BEFORE BEGINNING ANY SANITARY SEWER WORK.
8. UPON THE COMPLETION OF CONSTRUCTION A COMPLETE SET OF REPRODUCIBLE "AS-CONSTRUCTED" PLANS SHALL BE PROVIDED TO THE DISTRICT.
9. SANITARY SEWER SERVICE SHALL BE MAINTAINED AT ALL TIMES. THE CONTRACTOR SHALL USE WHATEVER MEANS ARE NECESSARY (E.G. PUMPS, ETC.) TO MAINTAIN THIS SERVICE DURING CONSTRUCTION.
10. PRIOR TO COMMENCING ANY SANITARY SEWER WORK IN OFF-SITE EASEMENTS THE CONTRACTOR SHALL PROVIDE THE DISTRICT WITH ADEQUATE EVIDENCE THAT ALL AFFECTED PROPERTY OWNERS (AND TENANTS WHERE APPLICABLE) WERE NOTIFIED WELL IN ADVANCE OF THE DATE WORK IN THESE EASEMENTS WAS TO BEGIN AND THAT THEY HAVE UPDATED THAT NOTICE IN A TIMELY MANNER WHEN THOSE DATES HAVE CHANGED.

**COUNTY OF SAN MATEO DEPARTMENT  
OF**

DRAWN BY: A.Z.  
CHECKED BY: K.L.  
APPROVED BY: A.M.S.

**PUBLIC WORKS**



REDWOOD CITY  
CALIFORNIA

SCALE: NONE  
DATE: 2-2022  
REVISED: 2-2022

**SAN MATEO COUNTY SEWER AND SANITATION DISTRICTS  
STANDARD SPECIFICATIONS**

**PIPE AND FITTINGS**

**POLYVINYL CHLORIDE PIPE (PVC)**

1. ALL PIPE AND FITTINGS SHALL CONFORM TO ASTM SPECIFICATIONS D3034, SDR 35.
2. ALL JOINTS SHALL BE A BELL AND SPIGOT ASSEMBLY WITH ELASTOMERIC SEALING GASKETS. SEALING GASKETS SHALL MEET THE REQUIREMENTS OF ASTM SPECIFICATION D1869. SOLVENT CEMENT JOINTS ARE NOT PERMITTED.
3. ALL PIPE ENTERING OR LEAVING A CONCRETE STRUCTURE SHALL HAVE A RUBBER WATERSTOP GASKET ATTACHED TO IT. THE WATERSTOP GASKET SHALL CONFORM TO THE PIPE MANUFACTURER'S SPECIFICATIONS. THE WATERSTOP GASKET SHALL BE SEATED FIRMLY AROUND THE PIPE EXTERIOR AND BE CAST INTO THE CONCRETE STRUCTURE.
4. ALL PIPE JOINTS SHALL BE MADE USING MANUFACTURED PVC COUPLINGS. BAND TYPE COMPRESSION COUPLINGS ARE NOT PERMITTED.

**DUCTILE IRON PIPE (DIP)**

1. ALL PIPE SHALL BE THICKNESS CLASS 50 (FOUR INCH PIPE SHALL BE THICKNESS CLASS 51) IN ACCORDANCE WITH ANSI SPECIFICATIONS A21.51. FITTINGS SHALL BE IN ACCORDANCE WITH ANSI SPECIFICATION A21.10.
2. JOINTS SHALL BE PUSH-ON TYPE OR MECHANICAL JOINT TYPE IN ACCORDANCE WITH ANSI SPECIFICATION A21.11. RUBBER GASKETS FOR PUSH-ON JOINTS SHALL BE IN ACCORDANCE WITH ANSI SPECIFICATIONS HEREIN.
3. PIPE AND FITTINGS SHALL HAVE A BITUMINOUS COATING OUTSIDE IN ACCORDANCE WITH ASTM SPECIFICATION A746-86, UNLESS OTHERWISE SPECIFIED HEREIN.
4. PIPE AND FITTINGS SHALL HAVE A 1/16" (ONE-SIXTEENTH INCH) CEMENT-MORTAR LINING WITH AN ASPHALTIC SEAL COAT.

**VITRIFIED CLAY PIPE (VCP)**

1. PIPE AND FITTINGS SHALL BE EXTRA STRENGTH, UNGLAZED, BELL AND SPIGOT, CONFORMING TO THE LATEST REVISION OF ASTM SPECIFICATION C700.
2. JOINTS SHALL BE A BELL AND SPIGOT ASSEMBLY WITH FACTORY INSTALLED FLEXIBLE COMPRESSION TYPE GASKETS MADE OF PLASTICIZED POLYVINYL OR POLYURETHANE CONFORMING TO THE LATEST REVISION OF ASTM SPECIFICATIONS C425. BAND TYPE COUPLINGS ARE NOT ALLOW.

**COUNTY OF SAN MATEO DEPARTMENT  
OF**

DRAWN BY: A.Z.  
 CHECKED BY: K.L.  
 APPROVED BY: A.M.S.

**PUBLIC WORKS**

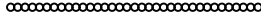

REDWOOD CITY  
 CALIFORNIA

SCALE: NONE  
 DATE: 2-2022  
 REVISED: 2-2022

**SAN MATEO COUNTY SEWER AND SANITATION DISTRICTS  
 STANDARD SPECIFICATIONS**

**TESTING REQUIREMENTS**

1. ALL REFERENCES TO "DISTRICT" IN THESE TESTING REQUIREMENTS SHALL MEAN THE APPROPRIATE COUNTY SEWER OR SANITATION DISTRICT.
2. ALL REQUIRED CLEANING AND TESTING OF SANITARY SEWER MAINS AND LATERALS SHALL BE PERFORMED IN THE PRESENCE OF A REPRESENTATIVE OF THE DISTRICT.
3. ALL SANITARY SEWER MAINS BEING CONSTRUCTED SHALL BE CLEANED BY MEANS OF A HIGH SPEED JET RODDER PRIOR TO TESTING. VCP AND DIP SHALL BE TESTED FOR OBSTRUCTION BY BALL ROLLING.
4. ALL SANITARY SEWER MAINS BEING CONSTRUCTED SHALL PASS A LOW PRESSURE AIR TEST. EACH SECTION OF MAIN SHALL BE TESTED BETWEEN SUCCESSIVE MANHOLES. THE LOW PRESSURE AIR TEST SHALL BE CONDUCTED IN THE FOLLOWING MANNER.

A COMPRESSED AIR SUPPLY SHALL BE ATTACHED TO AN AIR FITTING ON THE MAIN AND THE AIR PRESSURE WITHIN THE LINE INCREASED TO FOUR (4) POUNDS PER SQUARE INCH. (PSI). AFTER THE AIR SUPPLY IS SECURELY TURNED OFF OR DISCONNECTED, THERE SHALL BE A TWO (2) MINUTE WAITING PERIOD BEFORE THE ACTUAL TEST PERIOD BEGINS TO ALLOW STABILIZATION OF AIR WITHIN THE MAIN.

IN NO CASE SHALL THE AIR PRESSURE WITHIN THE LINE BE LESS THAN 3.5 PSI AT THE BEGINNING OF THE TEST PERIOD. REFER TO THE CHART WHICH FOLLOWS FOR THE LENGTH OF THE TEST PERIOD. THE MINIMUM LENGTH OF TEST IS TWO (2) MINUTES). THE ALLOWABLE AIR PRESSURE LOSS DURING THE TEST PERIOD SHALL BE 1.0 PSI. A WRITTEN RECORD OF THE TEST SHALL BE SUBMITTED TO THE DISTRICT BY THE CONTRACTOR.

<b>NOMINAL PIPE SIZE (inches)</b>	<b>LENGTH OF LINE (feet)</b>	<b>LENGTH OF TEST (minutes)</b>
4	ALL	2
6	0 – 300	2
6	300 – 370	2 1/2
6	370 AND GREATER	3
8	0 – 170	2
8	170 – 210	2 1/2
8	210 – 250	3
8	250 – 290	3 1/2
8	290 AND GREATER	3 3/4
10	0 – 110	2
10	110 – 165	3
10	165 – 215	4
10	215 AND GREATER	4 3/4



**COUNTY OF SAN MATEO DEPARTMENT  
OF**

DRAWN BY: A.Z.  
CHECKED BY: K.L.  
APPROVED BY: A.M.S.

**PUBLIC WORKS**

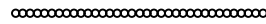

REDWOOD CITY  
CALIFORNIA

SCALE: NONE  
DATE: 2-2022  
REVISED: 2-2022

**SAN MATEO COUNTY SEWER AND SANITATION DISTRICTS  
STANDARD SPECIFICATIONS**

**TESTING REQUIREMENTS**

5. A TELEVISION INSPECTION SHALL BE MADE OF ALL SANITARY SEWER MAINS BEING CONSTRUCTED. IMMEDIATELY PRIOR TO TELEVISIONING THE SEWER, AN AMOUNT OF WATER ACCEPTABLE TO THE DISTRICT'S REPRESENTATIVE SHALL BE INTRODUCED INTO THE SEWER MAIN BEING INSPECTED.

A VIDEO TAPE IN VHS FORMAT AT SP, OR EQUIVALENT, SPEED SHALL BE MADE OF THE INSPECTION AND DELIVERED ALONG WITH A TYPED LOG OF THE INSPECTION TO THE DISTRICT (SAN MATEO COUNTY DEPARTMENT OF PUBLIC WORKS) FOR REVIEW AND ACCEPTANCE.

SUBMITTED VIDEO TAPES SHALL INCLUDE A CONTINUOUS ON-SCREEN DISPLAY WHICH CONTAINS, AS A MINIMUM, THE DATE OF THE FILMING, IDENTIFICATION OF THE LINE AND SEGMENT (REACH) OF THE LINE BEING VIEWED, AND A READOUT, IN FEET, SHOWING THE DISTANCE TO THE ENTRY POINT.

IF, IN THE OPINION OF THE DISTRICT, THE SUBMITTED VIDEO TAPES ARE OF POOR QUALITY, THE DISTRICT MAY REJECT THE VIDEO TAPES AND REQUIRE THE VIDEO INSPECTION TO BE REPEATED AND NEW VIDEO TAPES SUBMITTED TO THE DISTRICT FOR REVIEW AND ACCEPTANCE. ALL VIDEO TAPES SHALL BECOME THE PROPERTY OF THE DISTRICT.

6. DEFLECTION TESTING OF POLYVINYL CHLORIDE (PVC) SEWER MAINS SHALL BE PERFORMED AFTER THE PLACEMENT OF ALL TRENCH BACKFILL. PIPE DEFLECTION SHALL BE TESTED BY PULLING BY HAND A GO/NO-GO MANDREL THROUGH THE INSTALLED SECTIONS OF SEWER MAIN.

THE MANDREL USED SHALL HAVE A MINIMUM LENGTH EQUAL TO ITS DIAMETER. THE MANDREL SHALL BE CONSTRUCTED WITH A MINIMUM OF NINE (9) RIBS FABRICATED PARALLEL TO ITS LONGITUDINAL AXIS. BOTH THE DESIGN OF THE MANDREL AND THE FABRICATED MANDREL ITSELF SHALL BE INSPECTED AND APPROVED BY THE DISTRICT WELL IN ADVANCE OF THE DEFLECTION TEST.

THE MANDREL DIAMETER SHALL BE 95% OF THE PIPE'S AVERAGE INSIDE DIAMETER AS DEFINED BY ASTM SPECIFICATION D3034, AND AS DETAILED IN THE FOLLOWING TABLE:

<b>NOMINAL PIPE SIZE (inches)</b>	<b>AVERAGE INSIDE DIAMETER (inches)</b>	<b>MINIMUM MANDREL DIAMETER (inches)</b>
6	5.893	5.598
8	7.891	7.497
10	9.864	9.371

NOTE: AVERAGE INSIDE DIAMETER = AVERAGE OUTSIDE DIAMETER - 2(1.06)T; WHERE T = MINIMUM WALL THICKNESS AS DEFINED BY ASTM SPECIFICATION D3034.

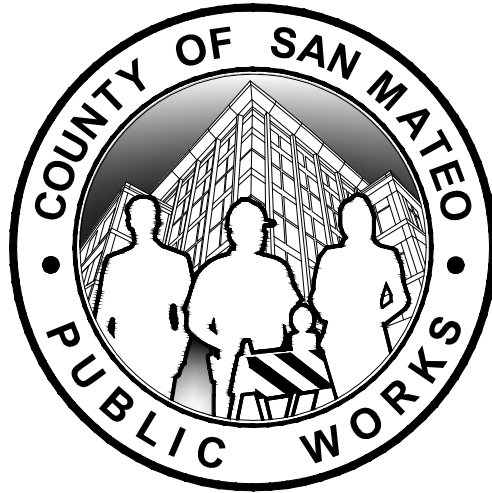

STANDARD DRAWINGS

FOR

PUBLIC IMPROVEMENT

---

**STANDARD  
STRUCTURES**

**COUNTY OF SAN MATEO DEPARTMENT  
OF**

DRAWN BY: A.Z.  
 CHECKED BY: K.L.  
 APPROVED BY: A.M.S.

**PUBLIC WORKS**



REDWOOD CITY  
CALIFORNIA

SCALE: NONE  
 DATE: 2-2022  
 REVISED: 2-2022

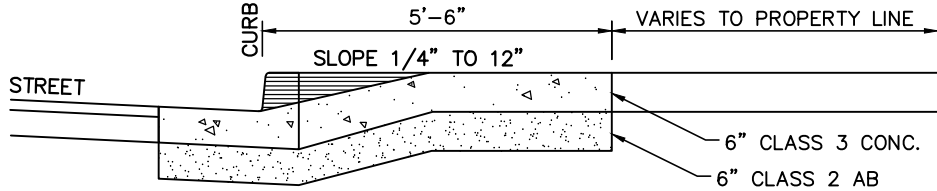

**SECTION**

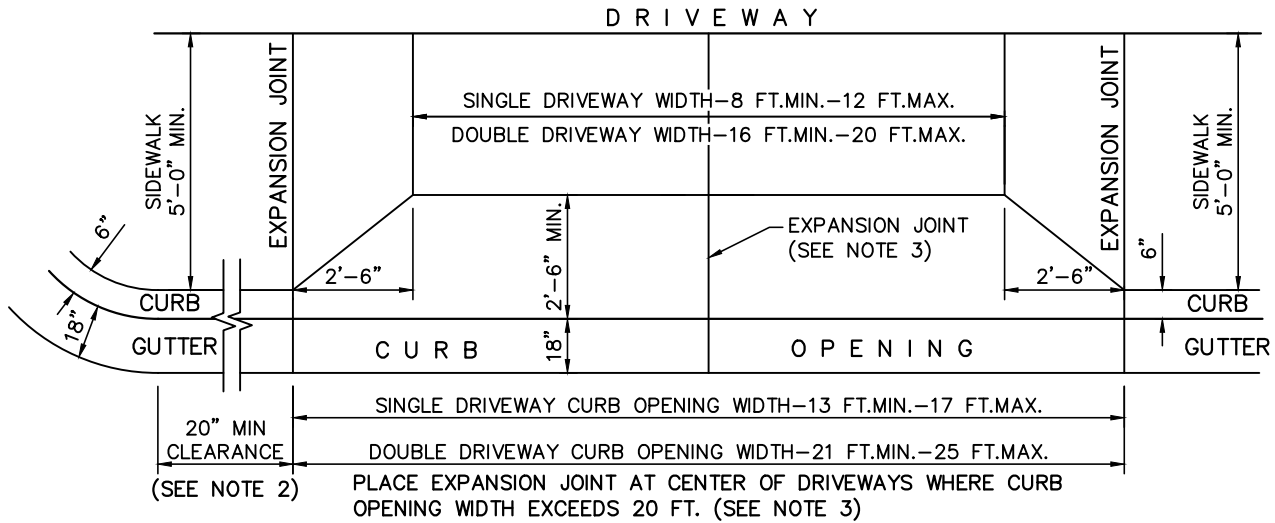

**PLAN**

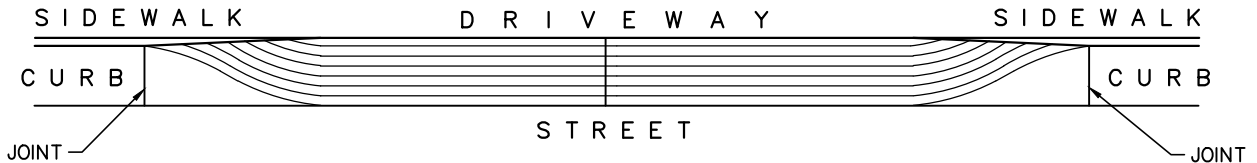

**ELEVATION**

**NOTES:**

- WHERE POSSIBLE, 22 FT. DISTANCES OR MULTIPLES OF 22 FT. DISTANCES SHOULD BE OBTAINED BETWEEN CURB OPENINGS. CONSTRUCT MONOLITHIC CURB, GUTTER, DRIVEWAY AND APRON. WHERE DRIVEWAYS OF SEPARATE RESIDENTIAL DWELLINGS ARE CONSTRUCTED ADJACENT TO ONE ANOTHER, DOUBLE THE DIMENSIONS SHOWN ABOVE. USE NO. 4 SMOOTH REINFORCING BAR DOWELS AS SHOWN ON STANDARD CURB, GUTTER AND SIDEWALK DETAIL D-3.
- EXISTING DRIVEWAYS MAY BE REPLACED AT EXISTING LOCATIONS, HOWEVER NEW OR NEWLY LOCATED DRIVEWAY MUST BE OFFSET A MIN OF 20 FT FROM THE END OF RETURN.
- EXPANSION JOINT FELT, NO FOAM OR OTHER MATERIAL. FELT 1/4" - 1/2" MAX. THICKNESS.

**STANDARD STRUCTURES  
 DRIVEWAY WIDTHS AND CURB OPENINGS  
 FOR SINGLE FAMILY RESIDENTIAL DWELLINGS**

**COUNTY OF SAN MATEO DEPARTMENT  
OF**

DRAWN BY: A.Z.  
 CHECKED BY: K.L.  
 APPROVED BY: A.M.S.

**PUBLIC WORKS**



REDWOOD CITY  
CALIFORNIA

SCALE: NONE  
 DATE: 2-2022  
 REVISED: 2-2022

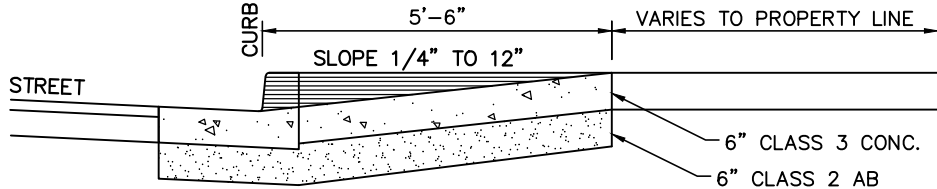

**SECTION**

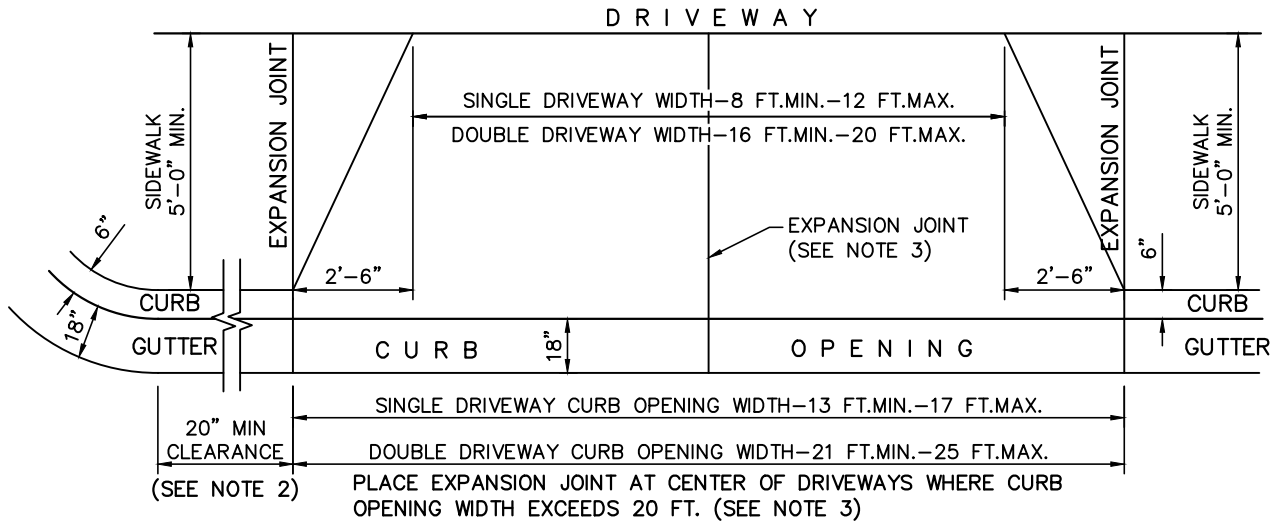

**PLAN**

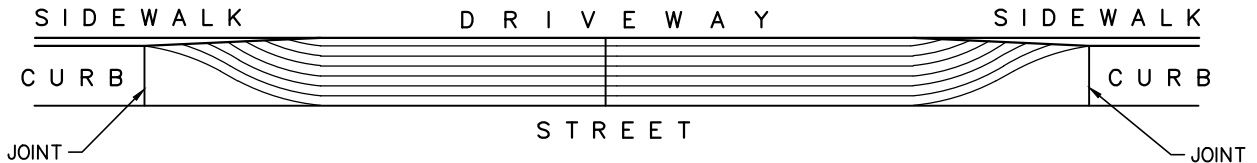

**ELEVATION**

**NOTES:**

1. WHERE POSSIBLE, 22 FT. DISTANCES OR MULTIPLES OF 22 FT. DISTANCES SHOULD BE OBTAINED BETWEEN CURB OPENINGS. CONSTRUCT MONOLITHIC CURB, GUTTER, DRIVEWAY AND APRON. WHERE DRIVEWAYS OF SEPARATE RESIDENTIAL DWELLINGS ARE CONSTRUCTED ADJACENT TO ONE ANOTHER, DOUBLE THE DIMENSIONS SHOWN ABOVE. USE NO. 4 SMOOTH REINFORCING BAR DOWELS AS SHOWN ON STANDARD CURB, GUTTER AND SIDEWALK DETAIL D-3.
2. EXISTING DRIVEWAYS MAY BE REPLACED AT EXISTING LOCATIONS, HOWEVER NEW OR NEWLY LOCATED DRIVEWAY MUST BE OFFSET A MIN OF 20 FT FROM THE END OF RETURN.
3. EXPANSION JOINT FELT, NO FOAM OR OTHER MATERIAL. FELT 1/4" - 1/2" MAX. THICKNESS.

**STANDARD STRUCTURES  
 DRIVEWAY WIDTHS AND CURB OPENINGS  
 FOR SINGLE FAMILY RESIDENTIAL DWELLINGS**

**COUNTY OF SAN MATEO DEPARTMENT  
OF**

DRAWN BY: A.Z.  
 CHECKED BY: K.L.  
 APPROVED BY: A.M.S.

**PUBLIC WORKS**



REDWOOD CITY  
CALIFORNIA

SCALE: NONE  
 DATE: 2-2022  
 REVISED: 2-2022

**NOTE:**

SEE D-3 FOR DOWEL DETAILS.

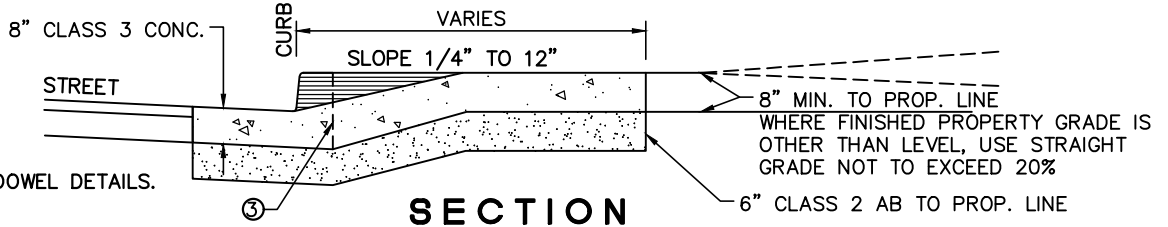

**SECTION**

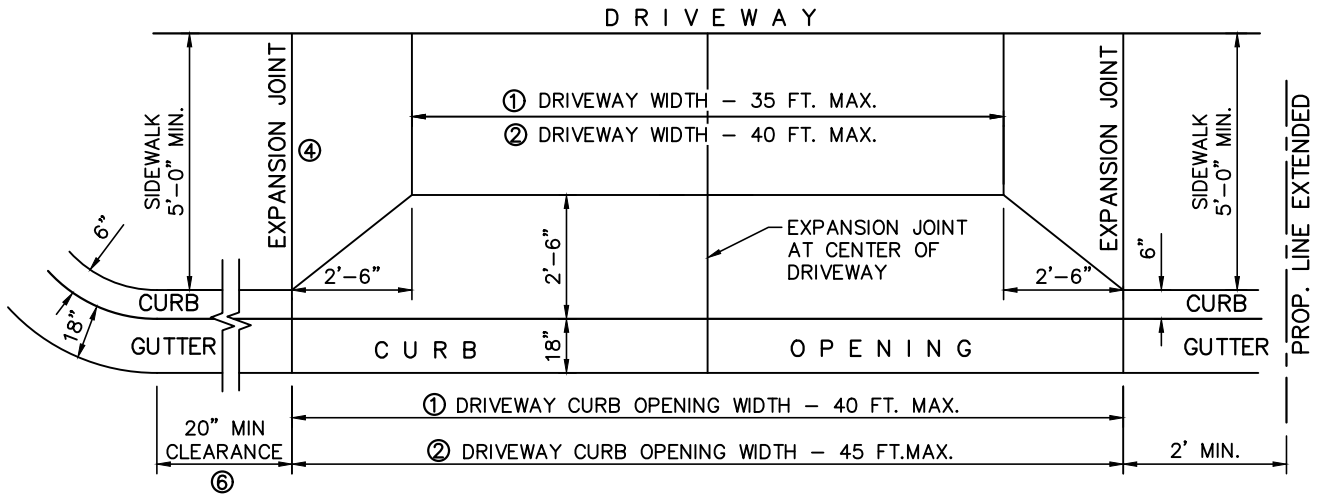

**PLAN**



**NOTES:**

- ① SPEED LIMIT OF 35 MPH OR LESS ALONG FRONTAGE STREET
- ② SPEED LIMIT OF 40 MPH OR MORE ALONG FRONTAGE STREET
- ③ CONSTRUCT MONOLITHIC CURB, GUTTER, DRIVEWAY AND APRON
- ④ USE NO.4 REINFORCING BAR DOWELS AS SHOWN ON STANDARD CURB, GUTTER & SIDEWALK DETAIL
- ⑤ FOR MORE THAN ONE DRIVEWAY
  - Ⓐ 23 FT. OR MULTIPLES OF 23 FT. BETWEEN CURB OPENINGS
  - Ⓑ TOTAL DRIVEWAY WIDTH--FRONTAGE
    - 70% OF FRONTAGE 100 FT. OR LESS
    - 60% OF FRONTAGE MORE THAN 100 FT.
- ⑥ EXISTING DRIVEWAYS MAY BE REPLACED AT EXISTING LOCATIONS, HOWEVER NEW OR NEWLY LOCATED DRIVEWAY MUST BE OFFSET A MIN OF 20 FT FROM THE END OF RETURN AT INTERSECTION.

**STANDARD STRUCTURES**

**DRIVEWAY WIDTHS AND CURB OPENINGS**

**FOR COMMERCIAL AND INDUSTRIAL HWY. FRONTAGE**

**COUNTY OF SAN MATEO DEPARTMENT  
OF**

DRAWN BY: A.Z.  
 CHECKED BY: K.L.  
 APPROVED BY: A.M.S.

**PUBLIC WORKS**



REDWOOD CITY  
CALIFORNIA

SCALE: NONE  
 DATE: 2-2022  
 REVISED: 2-2022

NOTE:  
 SEE D-3 FOR DOWEL DETAILS.

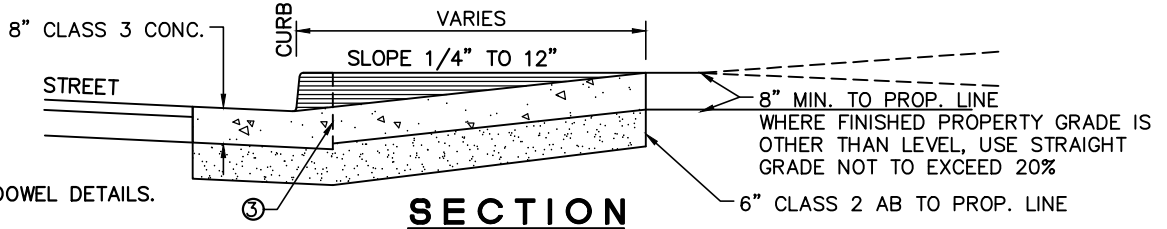

**DRIVEWAY**

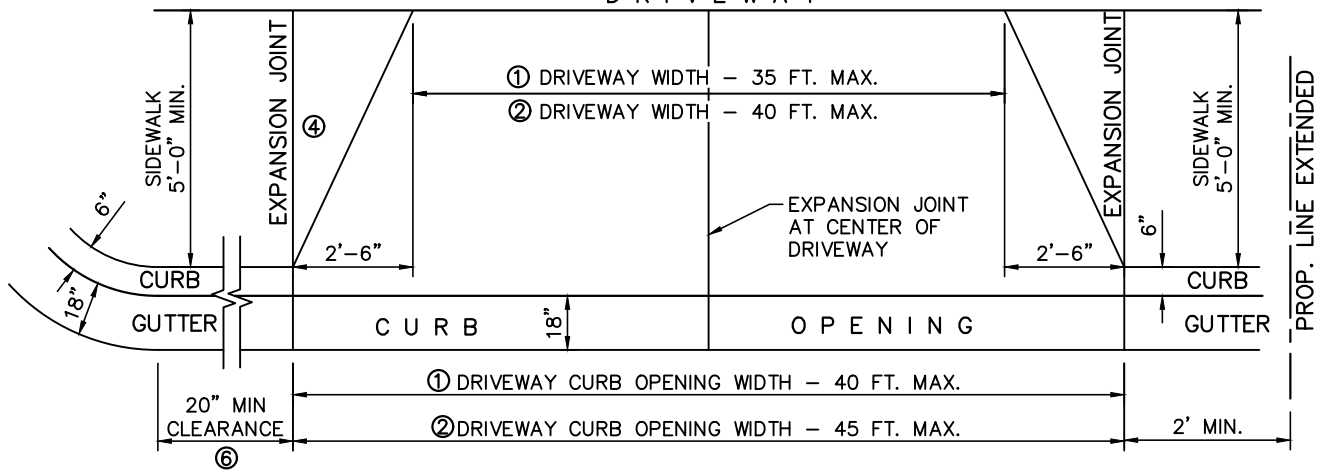

**PLAN**

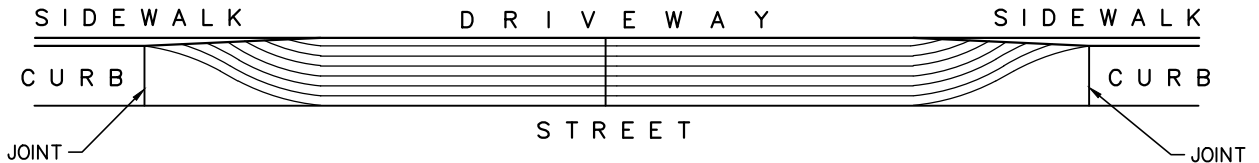

**ELEVATION**

NOTES:

- ① SPEED LIMIT OF 35 MPH OR LESS ALONG FRONTAGE STREET
- ② SPEED LIMIT OF 40 MPH OR MORE ALONG FRONTAGE STREET
- ③ CONSTRUCT MONOLITHIC CURB, GUTTER, DRIVEWAY AND APRON
- ④ USE NO.4 REINFORCING BAR DOWELS AS SHOWN ON STANDARD CURB, GUTTER & SIDEWALK DETAIL
- ⑤ FOR MORE THAN ONE DRIVEWAY
  - A 23 FT. OR MULTIPLES OF 23 FT. BETWEEN CURB OPENINGS
  - B TOTAL DRIVEWAY WIDTH--FRONTAGE
    - 70% OF FRONTAGE 100 FT. OR LESS
    - 60% OF FRONTAGE MORE THAN 100 FT.
- ⑥ EXISTING DRIVEWAYS MAY BE REPLACED AT EXISTING LOCATIONS, HOWEVER NEW OR NEWLY LOCATED DRIVEWAY MUST BE OFFSET A MIN OF 20 FT FROM THE END OF RETURN AT INTERSECTION.

**STANDARD STRUCTURES**

**DRIVEWAY WIDTHS AND CURB OPENINGS**

**FOR COMMERCIAL AND INDUSTRIAL HWY. FRONTAGE**

**COUNTY OF SAN MATEO DEPARTMENT  
OF**

DRAWN BY: A.Z.  
 CHECKED BY: K.L.  
 APPROVED BY: A.M.S.

**PUBLIC WORKS**



REDWOOD CITY  
CALIFORNIA

SCALE: NONE  
 DATE: 2-2022  
 REVISED: 2-2022

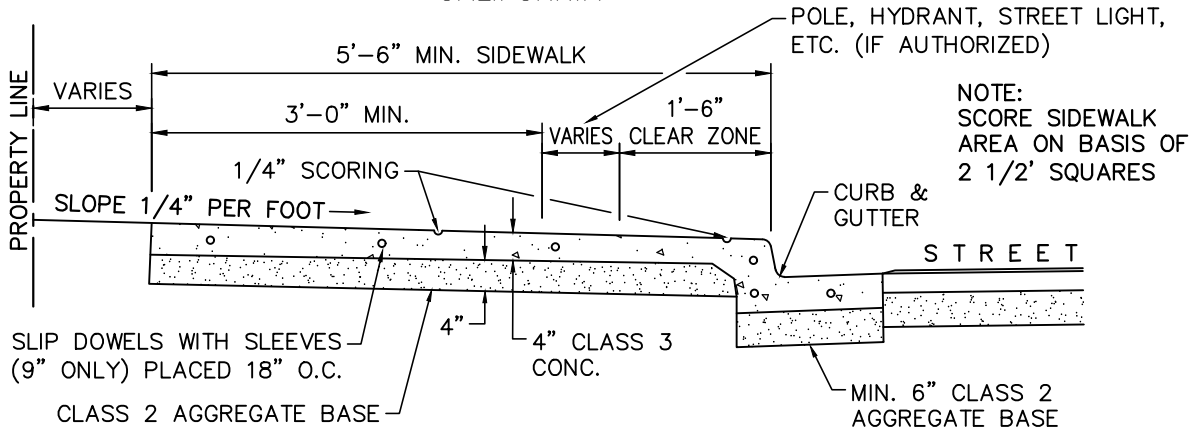

**URBAN CURB, GUTTER AND SIDEWALK  
TYPICAL SECTION**

**NOTES:**

1. OBSTRUCTIONS SUCH AS POLES, HYDRANTS, STREET SIGNS, UTILITY BOXES, STREET LIGHTS, ETC. SHALL BE LOCATED BEHIND THE SIDEWALK, UNLESS OTHERWISE SPECIFICALLY AUTHORIZED BY THE DIRECTOR OF PUBLIC WORKS. A CLEAR ZONE ALONG THE CURB AND SIDEWALK 18 INCHES IN WIDTH (MEASURED FROM THE FACE OF THE CURB) SHALL BE KEPT CLEAR AND OPEN FROM ALL OBSTRUCTIONS. IN ADDITION, AN AREA 3 FEET IN WIDTH ALONG THE SIDEWALK, EXCLUSIVE OF THE CURB WIDTH, SHALL BE KEPT CLEAR AND OPEN FROM ALL OBSTRUCTIONS IN COMPLIANCE WITH THE STATE BUILDING CODE (PART 2, TITLE 24, C.A.C.).
2. FOR SIDEWALK ACROSS DRIVEWAYS, SEE STANDARD DRIVEWAY DETAILS.

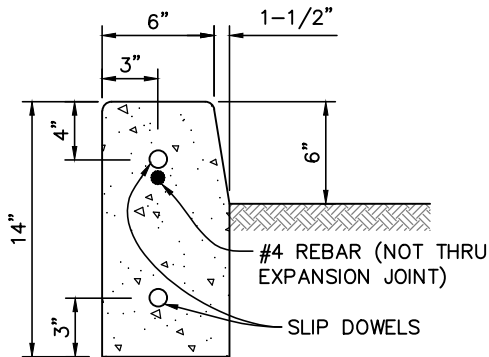

**A1-6 CURB**

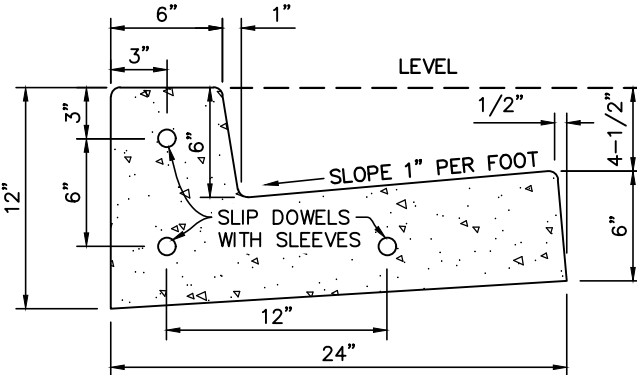

**CURB AND GUTTER**

**TYPICAL SECTIONS**

**NOTES:**

1. ALL CONCRETE TO BE CLASS 3 CONCRETE.
2. MINIMUM SIDEWALK THICKNESS = 4 INCHES PCC.
3. PLACE 1/2" DIAMETER X 18" LONG DOWELS AT EXPANSION JOINTS AS SHOWN.
4. PLACE 1/2" THICK FELT EXPANSION JOINTS FULL WIDTH 20' ON CENTER.
5. CONSTRUCT MONOLITHIC CURB, GUTTER AND SIDEWALK UNLESS OTHERWISE SPECIFICALLY AUTHORIZED BY THE DIRECTOR OF PUBLIC WORKS.
6. SUB-BASE MATERIALS WITHIN 30" OF SUBGRADE SHALL BE COMPACTED TO 95%.

**CONCRETE CURB, GUTTER, AND SIDEWALK DETAILS**

COUNTY OF SAN MATEO DEPARTMENT  
OF

PUBLIC WORKS

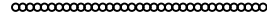

REDWOOD CITY  
CALIFORNIA

DRAWN BY: A.Z.  
CHECKED BY: K.L.  
APPROVED BY: A.M.S.

SCALE: NONE  
DATE: 2-2022  
REVISED: 2-2022

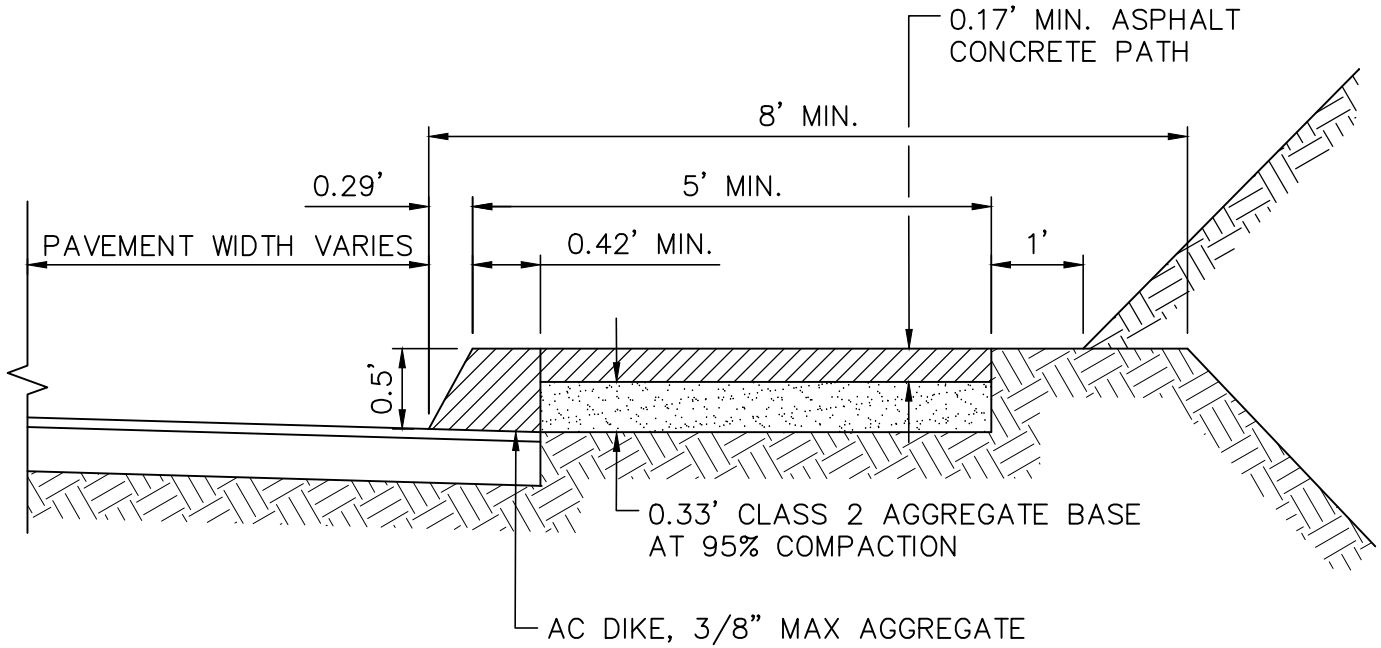

A.C. DIKE AND PATH DETAIL



**COUNTY OF SAN MATEO DEPARTMENT  
OF**

**PUBLIC WORKS**

.....  
REDWOOD CITY  
CALIFORNIA

DRAWN BY: A.Z.  
CHECKED BY: K.L.  
APPROVED BY: A.M.S.

SCALE: NONE  
DATE: 2-2022  
REVISED: 2-2022

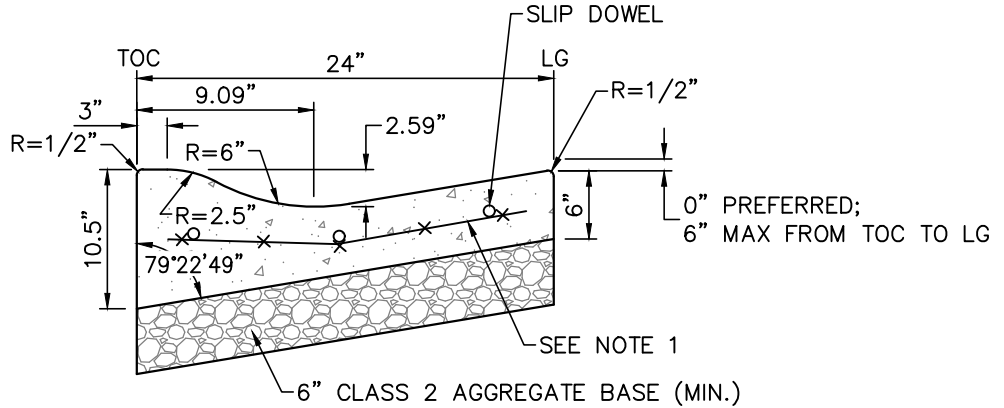

**NOTES:**

1. REINFORCEMENT SHALL CONSIST OF 6" x 6" - #10/#10 WELDED WIRE FABRIC.
2. CONCRETE ROLLED GUTTER SHALL BE INSTALLED PRIOR TO PAVING, UNLESS ENGINEER APPROVES OTHERWISE.
3. PLACE 1/2" DIAMETER x 18" LONG DOWELS, AT EXPANSION JOINTS, AS SHOWN.
4. PLACE 1/4" THICK EXPANSION JOINTS FULL WIDTH 20' ON CENTER.
5. SUB-BASE MATERIALS WITHIN 30" OF SUBGRADE SHALL BE COMPACTED TO 95% R.C.
6. PLACE 1/4" DEEP SCORE FULL WIDTH 10' ON CENTER, BETWEEN EXPANSION JOINTS.
7. SEE D-3 FOR DOWELING DETAIL.

**2' CONCRETE ROLLED GUTTER**

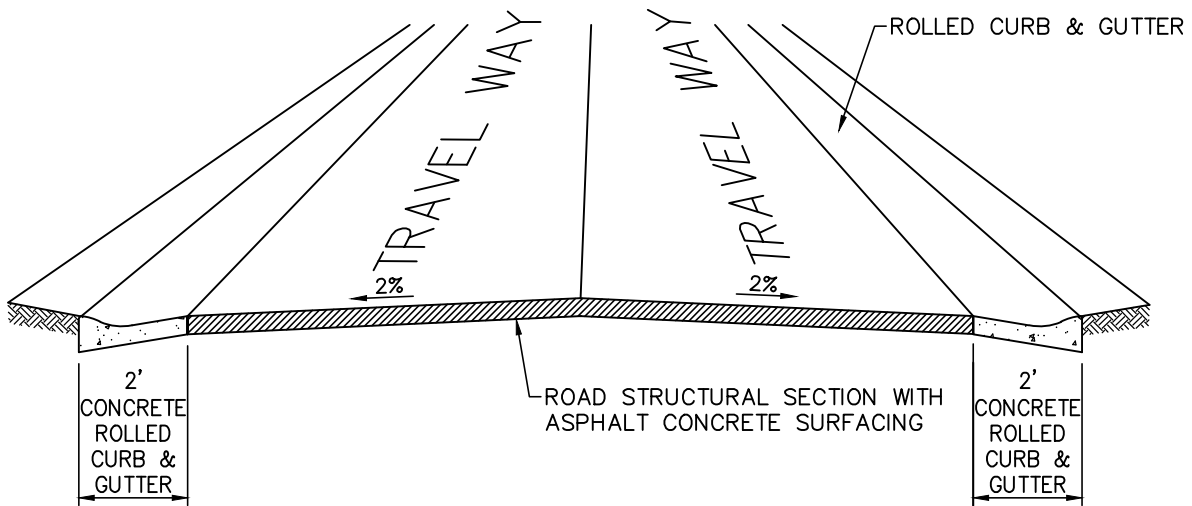

**NOTES:**

1. OTHER IMPROVEMENTS MAY EXIST THAT WERE CONSTRUCTED PRIOR TO ADOPTION OF SPECIFIC STANDARDS.
2. OPTIONAL ADDITIONAL IMPROVEMENTS MAY BE INSTALLED AFTER OBTAINING AN ENCROACHMENT PERMIT. THE COST OF OPTIONAL IMPROVEMENTS WILL BE AT THE SOLE EXPENSE OF APPLICANT.

**ROLLED CURB ROAD STANDARD**

**COUNTY OF SAN MATEO DEPARTMENT  
OF**

**PUBLIC WORKS**

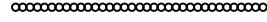

REDWOOD CITY  
CALIFORNIA

DRAWN BY: A.Z.  
CHECKED BY: K.L.  
APPROVED BY: A.M.S.

SCALE: NONE  
DATE: 2-2022  
REVISED: 2-2022

**NOTE:**

1. SCORE SIDEWALK AREA WITH 1/4" SCORING ON BASIS OF 2.5' SQUARES.

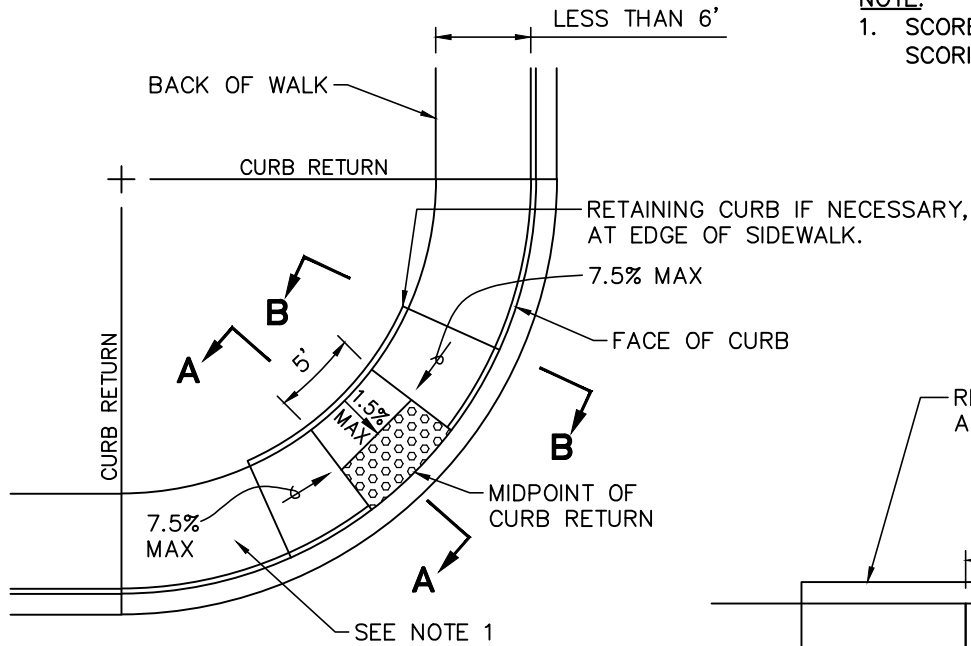

**PLAN**

**ACCESS RAMP ON CURB RETURN**

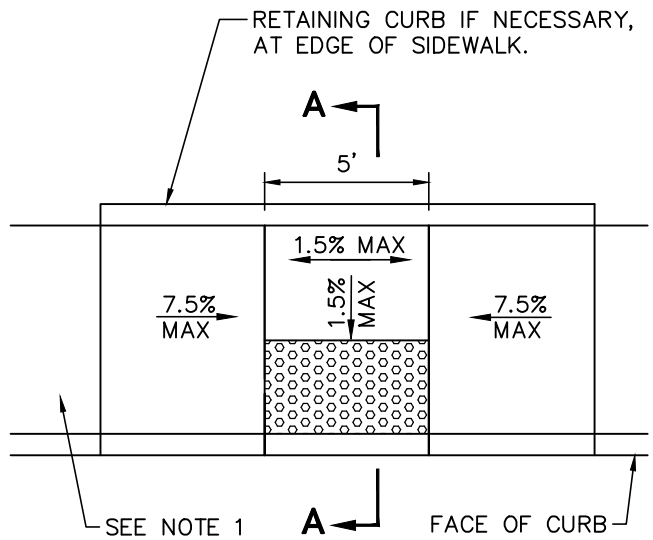

**PLAN**

**ACCESS RAMP ON TANGENT**  
USE WHEN SIDEWALK IS LESS THAN 6' WIDE

**SIDEWALK ACCESS RAMP  
FOR SIDEWALKS LESS THAN 6' WIDE**

(SHEET 1 OF 3)

**COUNTY OF SAN MATEO DEPARTMENT  
OF**

DRAWN BY: A.Z.  
 CHECKED BY: K.L.  
 APPROVED BY: A.M.S.

**PUBLIC WORKS**

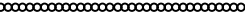

REDWOOD CITY  
CALIFORNIA

SCALE: NONE  
 DATE: 2-2022  
 REVISED: 2-2022

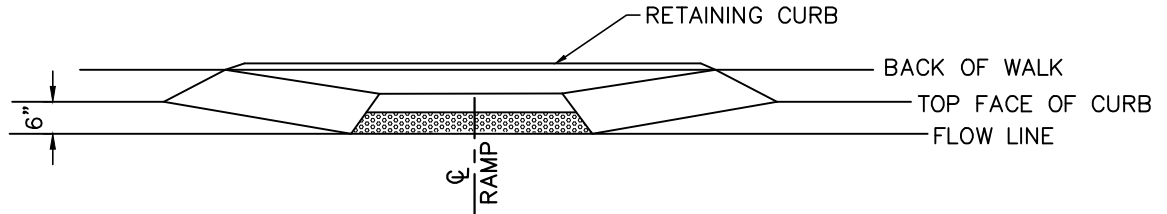

**PERSPECTIVE**

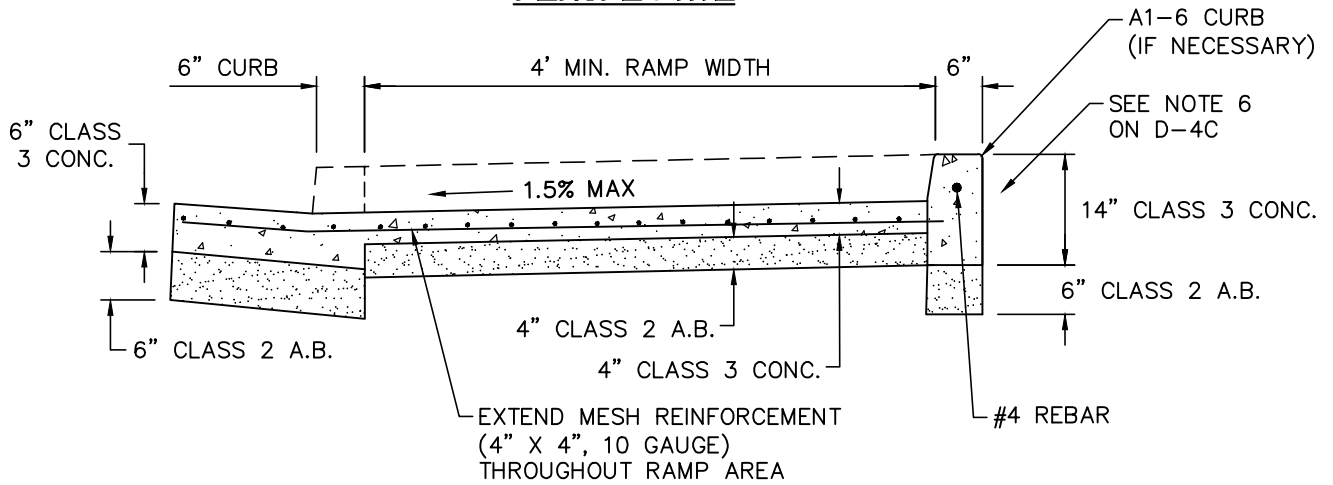

**SECTION A-A**

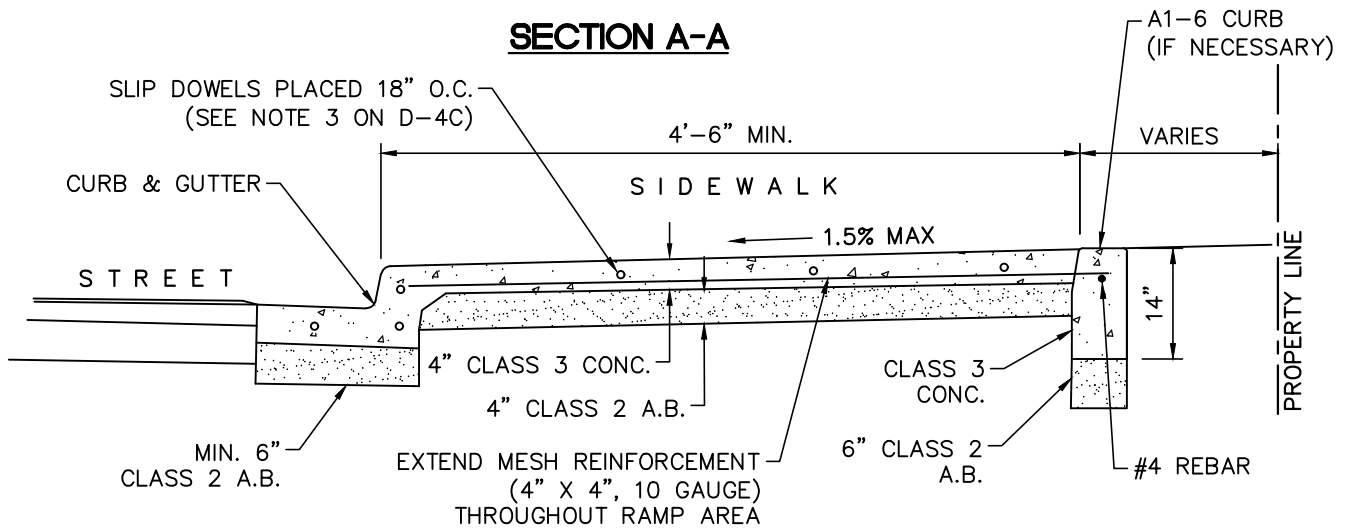

**SECTION B-B**

**SIDEWALK ACCESS RAMP  
FOR SIDEWALKS LESS THAN 6' WIDE**

(SHEET 2 OF 3)

**COUNTY OF SAN MATEO DEPARTMENT  
OF**

DRAWN BY: A.Z.  
CHECKED BY: K.L.  
APPROVED BY: A.M.S.

**PUBLIC WORKS**

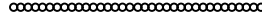

REDWOOD CITY  
CALIFORNIA

SCALE: NONE  
DATE: 2-2022  
REVISED: 2-2022

**GENERAL NOTES**

1. CURB RAMPS SHALL HAVE A DETECTABLE WARNING SURFACE THAT EXTENDS THE FULL WIDTH AND 3'-0" DEPTH OF THE RAMP. DETECTABLE WARNING SURFACES SHALL CONFORM TO THE REQUIREMENTS IN THE STANDARD SPECIFICATIONS. DARK GRAY TRUNCATED DOMES TO BE USED AS DETECTABLE WARNING SURFACES UNLESS NOTED OTHERWISE. YELLOW TRUNCATED DOMES TO BE USED AT SCHOOL INTERSECTIONS AND WITHIN CALTRANS R.O.W.
2. TRANSITIONS FROM RAMPS TO WALKS SHALL BE FLUSH AND FREE OF ABRUPT CHANGES.
3. INSTALL SLIP DOWELS 18" O.C. AT EXPANSION JOINTS.
4. MINIMUM WIDTH OF RAMP, NOT INCLUDING RETAINING CURB, SHALL BE 4 FEET.
5. THE SURFACE OF RAMP SHALL HAVE A TRANSVERSE BROOMED SURFACE TEXTURE ROUGHER THAN THE SURROUNDING SIDEWALK EXCEPT WHEN LOCATED IN CENTER OF CURB RETURN.
6. BACKFILL MATERIAL TO BE PLACED FLUSH WITH TOP OF CURB.
7. CONSTRUCT MONOLITHIC CURB, GUTTER, AND SIDEWALK.
8. SUB-BASE MATERIAL WITHIN 2.5' OF SUBGRADE SHALL BE COMPACTED TO 95%.
9. RECONSTRUCT SIDEWALK TO NEAREST SCORE LINE AND INSTALL EXPANSION JOINT.
10. UTILITY PULL BOXES, MANHOLES, VAULTS AND ALL OTHER UTILITY FACILITIES WITHIN THE BOUNDARIES OF THE CURB RAMP WILL BE RELOCATED BY OTHERS PRIOR TO, OR IN CONJUNCTION WITH, CURB RAMP CONSTRUCTION.
11. REFERENCE COUNTY DETAIL D-3.

**SIDEWALK ACCESS RAMP**  
**FOR SIDEWALKS LESS THAN 6' WIDE**

(SHEET 3 OF 3)

D-4C

**COUNTY OF SAN MATEO DEPARTMENT  
OF**

DRAWN BY: A.Z.  
 CHECKED BY: K.L.  
 APPROVED BY: A.M.S.

**PUBLIC WORKS**

.....  
 REDWOOD CITY  
 CALIFORNIA

SCALE: NONE  
 DATE: 2-2022  
 REVISED: 2-2022

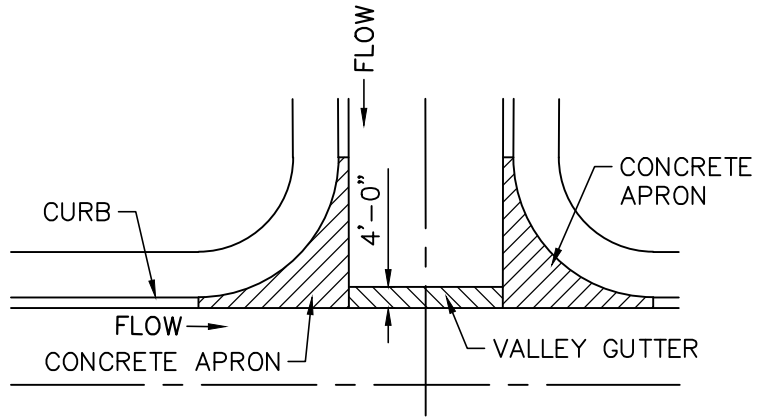
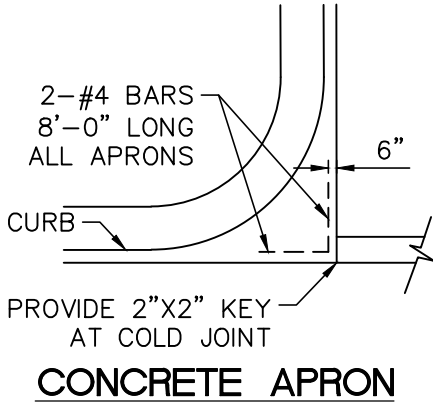

**VALLEY GUTTER  
 INTERSECTION PLAN**

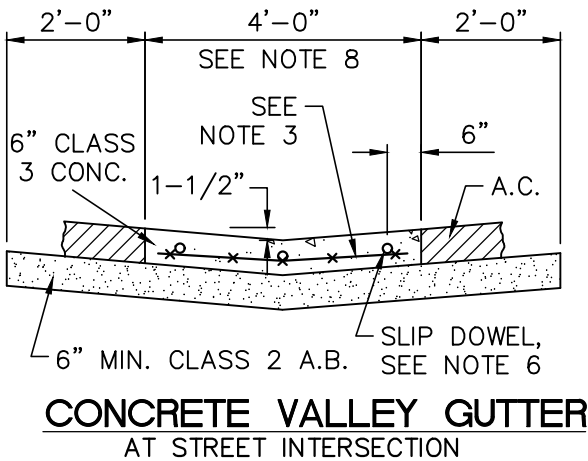

**NOTES:**

1. OMIT GUTTER AROUND RETURN. SLOPE ALL PARTS OF APRON FROM CURB TO NEAREST FLOW LINE WITHIN LIMITS OF VALLEY GUTTER.
2. APRON TO BE 8" MIN. THICK CLASS 3 P.C.C. OVER MIN. 6" COMPACTED CLASS 2 A.B.
3. REINFORCEMENT SHALL CONSIST OF 6"X6"-#10/#10 WELDED WIRE FABRIC.
4. APRONS SHALL BE POURED MONOLITHIC WITH ADJACENT CURB AND GUTTER.
5. CONCRETE VALLEY GUTTER AND APRONS SHALL BE INSTALLED PRIOR TO PAVING.
6. PLACE 1/2" DIAMETER X 18" LONG SLIP DOWELS, AT EXPANSION JOINTS, AS SHOWN.
7. PLACE 1/4" THICK EXPANSION JOINTS FULL WIDTH 20' ON CENTER. DEEP SCORE AT 10' INTERVALS BETWEEN EXPANSION JOINTS.
8. WIDTH OF VALLEY GUTTER SHALL BE AS DETERMINED BY DPW.

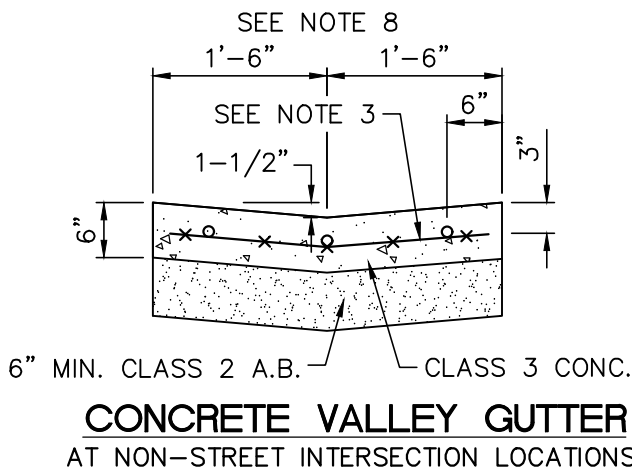

**VALLEY GUTTER DETAILS**

**COUNTY OF SAN MATEO DEPARTMENT  
OF**

DRAWN BY: A.Z.  
 CHECKED BY: K.L.  
 APPROVED BY: A.M.S.

**PUBLIC WORKS**

.....  
 REDWOOD CITY  
 CALIFORNIA

SCALE: NONE  
 DATE: 2-2022  
 REVISED: 2-2022

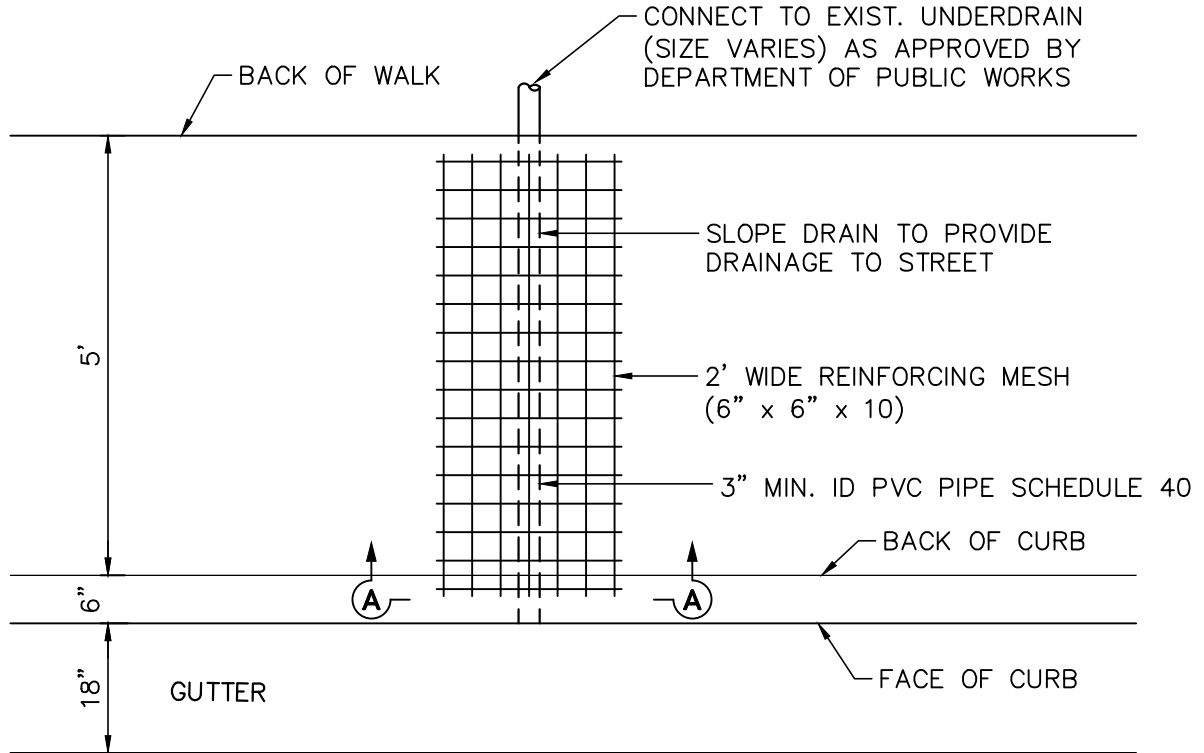

**PLAN**

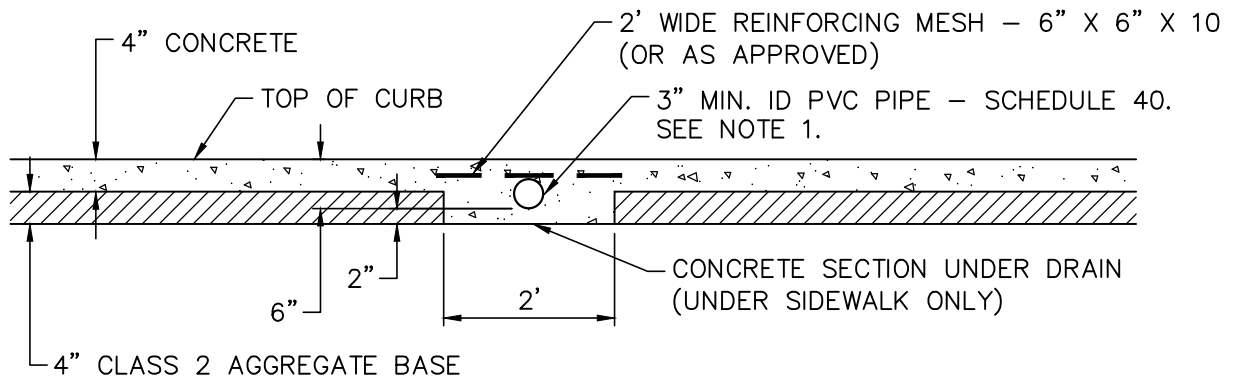

**SECTION A-A**

**NOTE:**

1. EDGE OF PIPES SHALL HAVE A 6" MIN. CLEARANCE FOR MULTIPLE PIPES.

**DRAINAGE UNDER SIDEWALK**

**COUNTY OF SAN MATEO DEPARTMENT  
OF**

DRAWN BY: A.Z.  
 CHECKED BY: K.L.  
 APPROVED BY: A.M.S.

**PUBLIC WORKS**

REDFORD CITY  
 CALIFORNIA

SCALE: NONE  
 DATE: 2-2022  
 REVISED: 2-2022

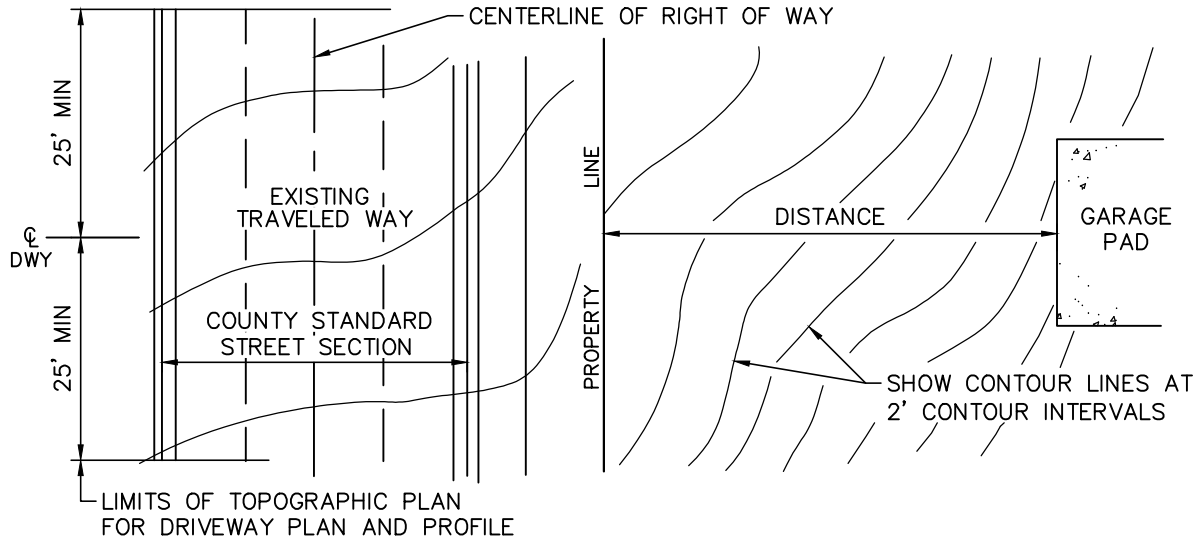

**DRIVEWAY PLAN VIEW**

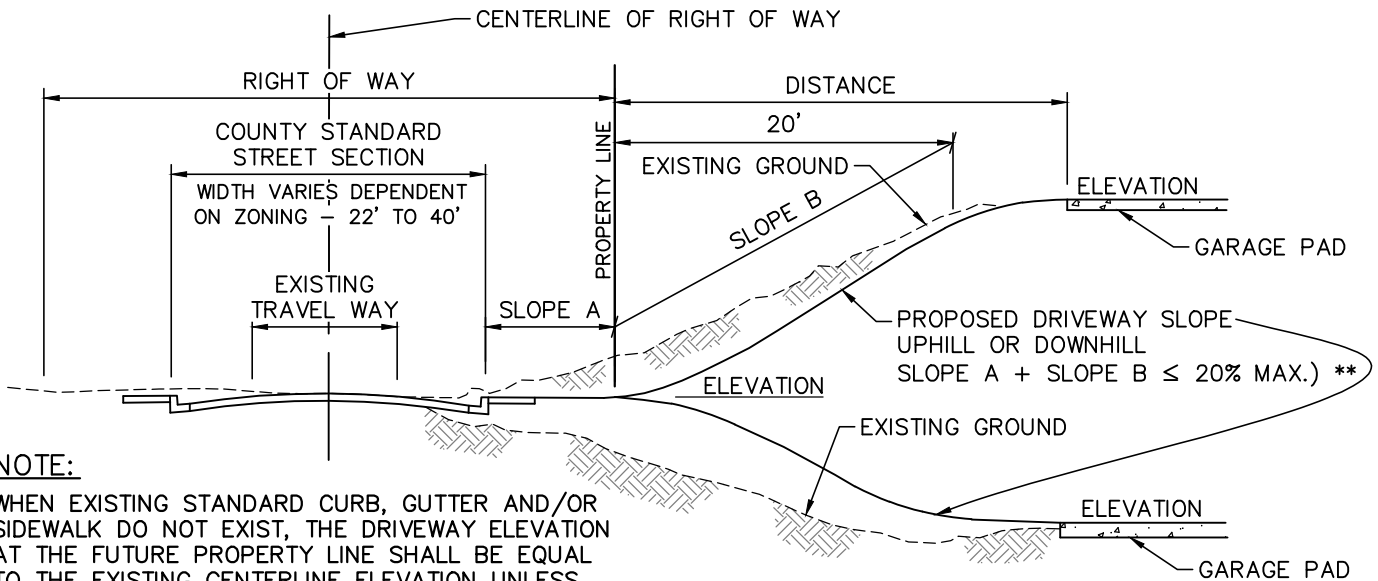

**NOTE:**

WHEN EXISTING STANDARD CURB, GUTTER AND/OR SIDEWALK DO NOT EXIST, THE DRIVEWAY ELEVATION AT THE FUTURE PROPERTY LINE SHALL BE EQUAL TO THE EXISTING CENTERLINE ELEVATION UNLESS FUTURE STREET GRADES HAVE BEEN ESTABLISHED BY THE COUNTY

\*\* GREATER SLOPES MAY CAUSE VEHICLES TO "BOTTOM OUT"

**DRIVEWAY PROFILE VIEW**

**AT CENTERLINE OF ROAD AND EDGE OF ROADWAY**

**COUNTY OF SAN MATEO DEPARTMENT  
OF**

DRAWN BY: A.Z.  
 CHECKED BY: K.L.  
 APPROVED BY: A.M.S.

**PUBLIC WORKS**

.....  
 REDWOOD CITY  
 CALIFORNIA

SCALE: NONE  
 DATE: 2-2022  
 REVISED: 2-2022

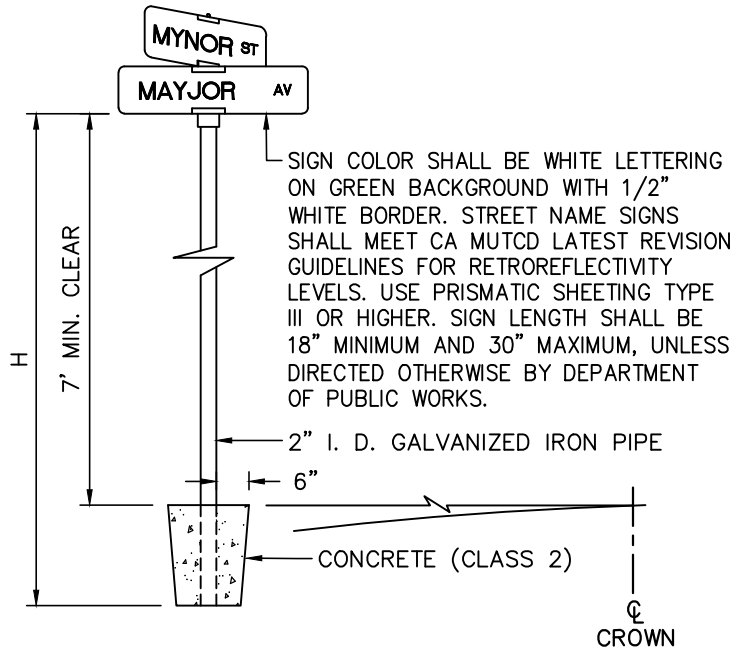
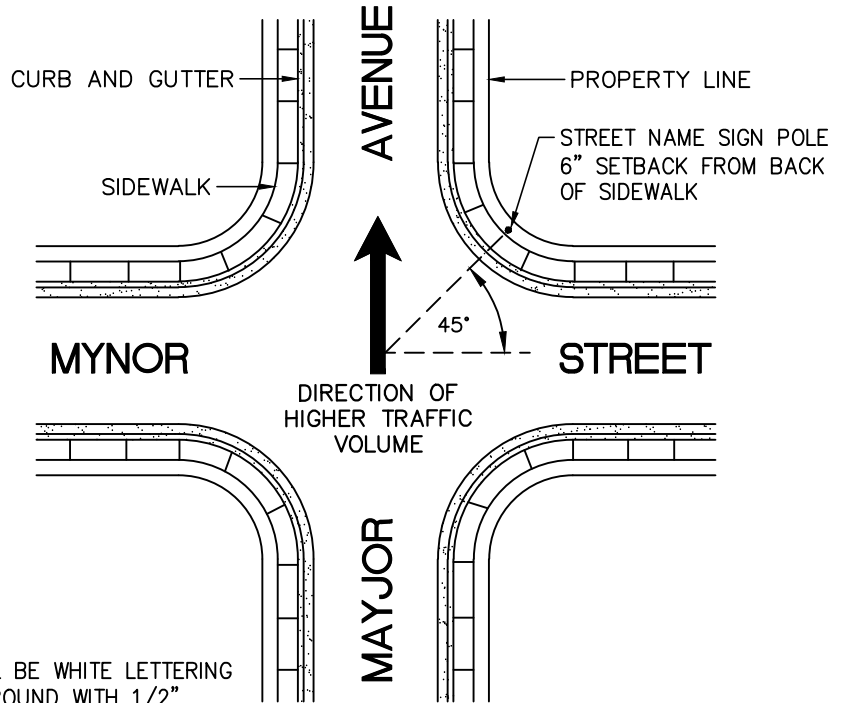

**STREET NAME SIGNS LETTERING SIZE:**

- SPEED LIMIT: 25 MPH OR LESS ----- 4"
- SPEED LIMIT: 40 MPH OR LESS ----- 6"
- SPEED LIMIT: MORE THAN 40 MPH ----- 8"
- SUPPLEMENTARY LETTER (ST, AVE, ETC.) ----- 3"

**NOTE:**  
 LOWER CASE LETTERS SHALL BE 3/4 OF SIZE SHOWN ABOVE.

H = TOTAL HEIGHT OF POLES

EMBEDMENT DEPTH FOR POLES SHALL NOT BE LESS THAN H/6 OR 2 FEET, WHICHEVER IS GREATER.

**COUNTY OF SAN MATEO STANDARD  
STREET NAME SIGN**



**COUNTY OF SAN MATEO DEPARTMENT  
OF**

**PUBLIC WORKS**

.....  
REDWOOD CITY  
CALIFORNIA

DRAWN BY: A.Z.  
CHECKED BY: K.L.  
APPROVED BY: A.M.S.

SCALE: NONE  
DATE: 2-2022  
REVISED: 2-2022

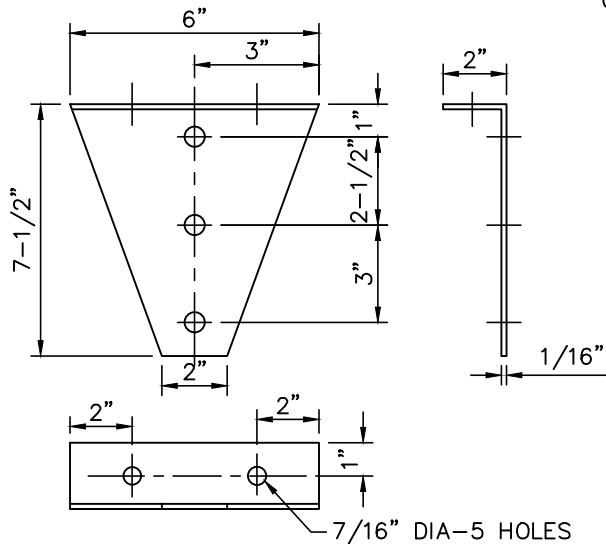
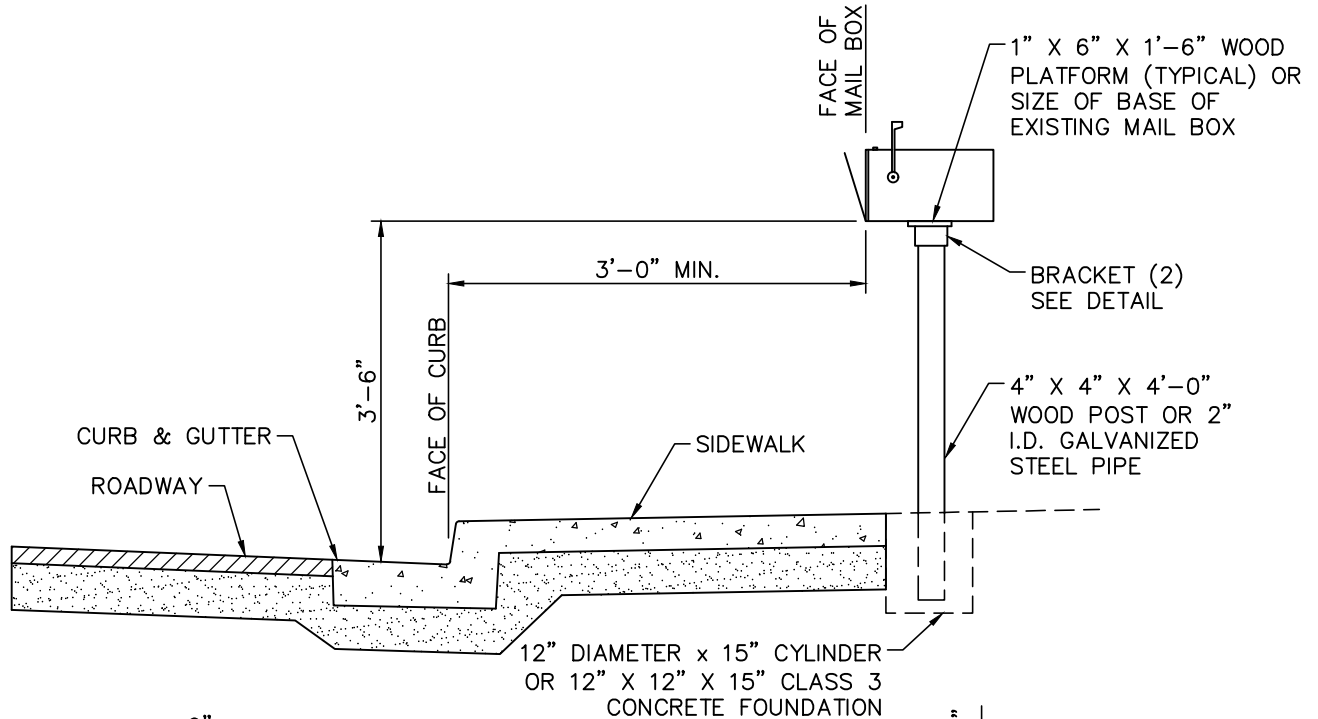

**FOR STEEL PIPE AND PLATFORM**

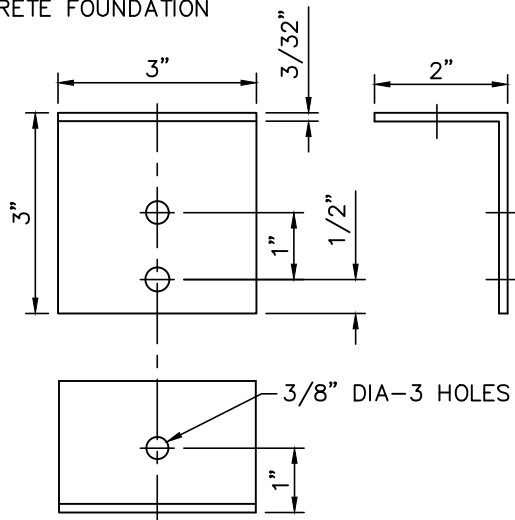

**FOR WOOD POST AND PLATFORM**

**BRACKET DETAILS**

- NOTES:**
1. ALL WOOD TO BE REDWOOD, CONSTRUCTION HEART GRADE, S4S
  2. ALL METAL TO BE GALVANIZED STEEL.

**MAIL BOX LOCATION AND CONSTRUCTION DETAILS**

**COUNTY OF SAN MATEO DEPARTMENT  
OF**

**PUBLIC WORKS**

.....  
REDWOOD CITY  
CALIFORNIA

DRAWN BY: A.Z.  
CHECKED BY: K.L.  
APPROVED BY: A.M.S.

SCALE: NONE  
DATE: 2-2022  
REVISED: 2-2022

**NOTES:**

1. MONUMENT FRAME & COVER SHALL BE PHOENIX IRON WORKS P-2001-A WITH MONUMENT COVER OR APPROVED EQUAL.
  - \* 2. BRASS MARKER FURNISHED BY COUNTY, (CONCRETE SHALL BE PACKED TIGHTLY AROUND STEM OF BRASS MARKER).
  3. 6" & 10" DIA. CYLINDERS TO BE FURNISHED BY CONTRACTOR.
  4. CONCRETE SHALL BE CLASS 2 (RODDED OR VIBRATED).
  5. MONUMENT CASTING SHALL BE HELD SECURELY IN PLACE (TO FINISH LINE & GRADE) PRIOR TO POURING THE UPPER 4-1/2 INCHES OF CONCRETE. (SUGGESTED METHOD - WIRE THE CASTING TO A 2" X 4" TIMBER 3 FEET LONG).
  6. MONUMENT CASTINGS SHALL BE INSTALLED AFTER THE FINAL SURFACE COURSE HAS BEEN COMPLETED.
- \* FURNISHED BY PROJECT ENGINEER ON NON-COUNTY PROJECT.

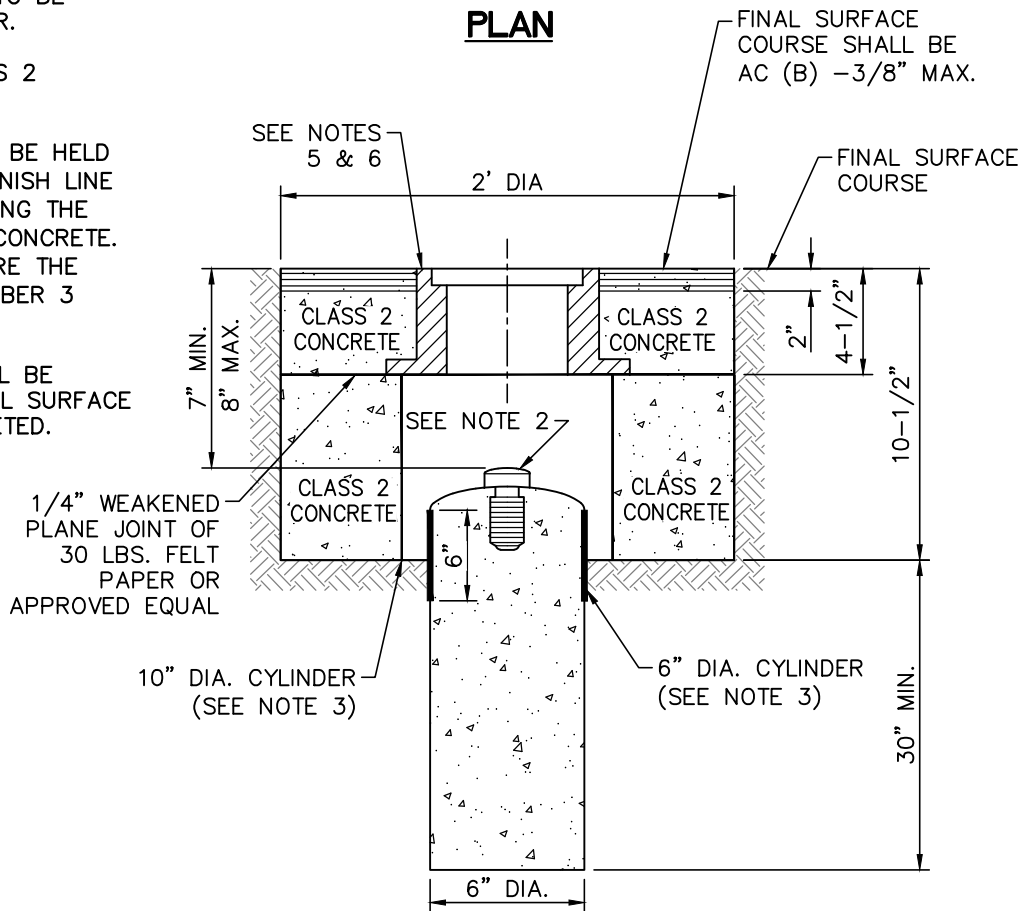
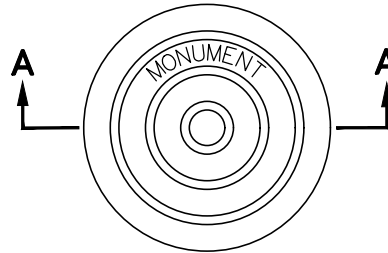

**SECTION A-A**

**STANDARD STRUCTURES  
MONUMENT, FRAME AND COVER**

**COUNTY OF SAN MATEO DEPARTMENT  
OF**

DRAWN BY: A.Z.  
 CHECKED BY: K.L.  
 APPROVED BY: A.M.S.

**PUBLIC WORKS**



REDWOOD CITY  
CALIFORNIA

SCALE: NONE  
 DATE: 2-2022  
 REVISED: 2-2022

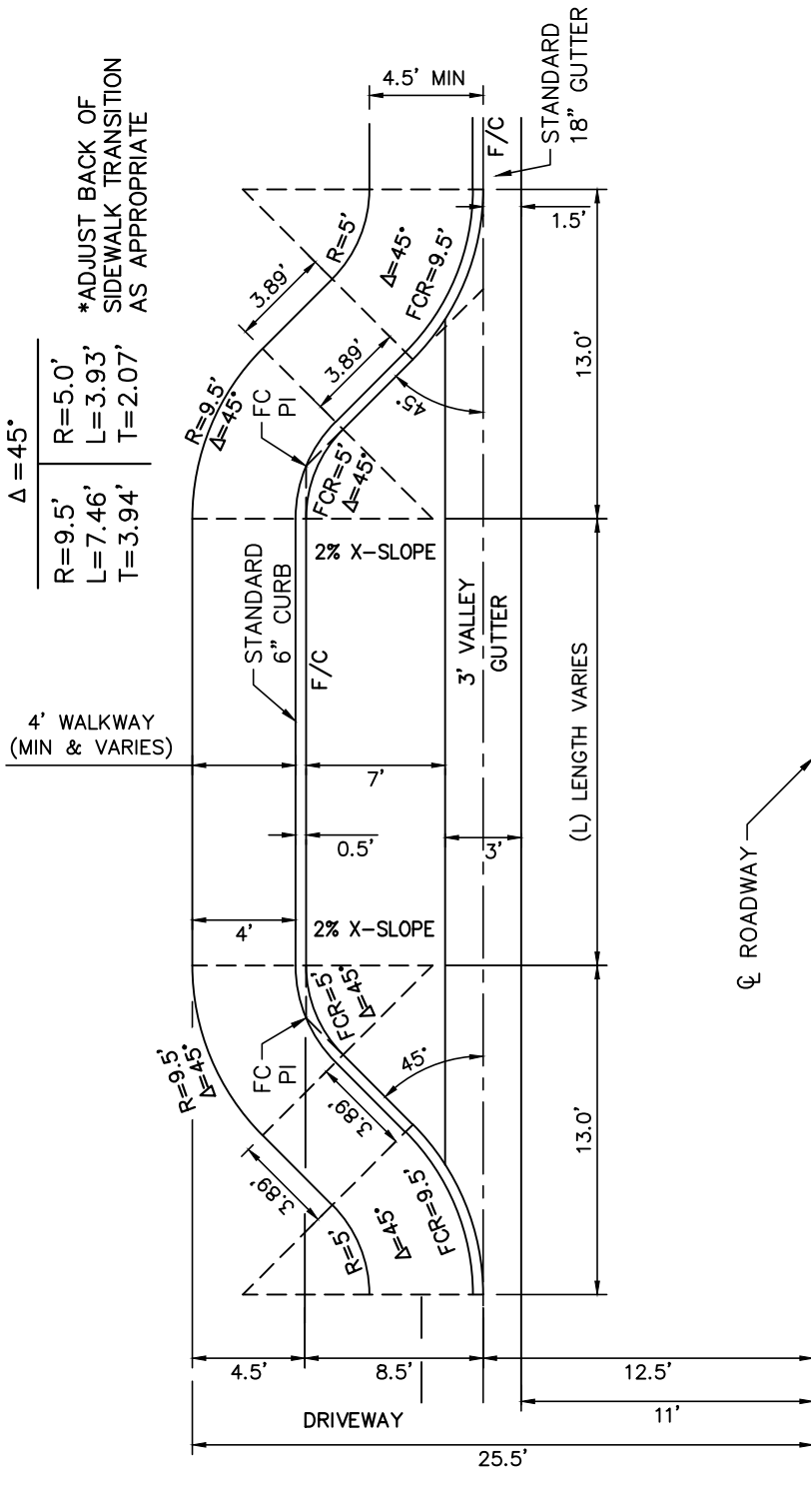

**TYPICAL PARKING BAY (P-1)**

(NOT FOR USE IN MONTARA/MOSS BEACH)

AREA OF SIDEWALK FROM END OF PARKING BAY TO END OF PARKING BAY (SEE NOTE 1) (FT <sup>2</sup> )	AREA OF CURB FROM END OF PARKING BAY TO END OF PARKING BAY (FT <sup>2</sup> )	AREA OF AC FROM END OF PARKING BAY TO END OF PARKING BAY (FT <sup>2</sup> )	AREA OF VALLEY FROM GUTTER FROM END OF PARKING BAY TO END OF PARKING BAY (FT <sup>2</sup> )	LENGTH OF CURB FROM END OF PARKING BAY TO END OF PARKING BAY (FT)
122.226+4L	15.278+0.5L	52.206+7L	67.57+3L	30.5564+L

**NOTES:**

1. AREA OF SIDEWALK APPROXIMATION FOR 4' WALKWAY ONLY.
2. "L" MUST BE IN FEET

**COUNTY OF SAN MATEO DEPARTMENT  
OF**

DRAWN BY: A.Z.  
 CHECKED BY: K.L.  
 APPROVED BY: A.M.S.

**PUBLIC WORKS**

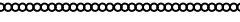

REDWOOD CITY  
CALIFORNIA

SCALE: NONE  
 DATE: 2-2022  
 REVISED: 2-2022

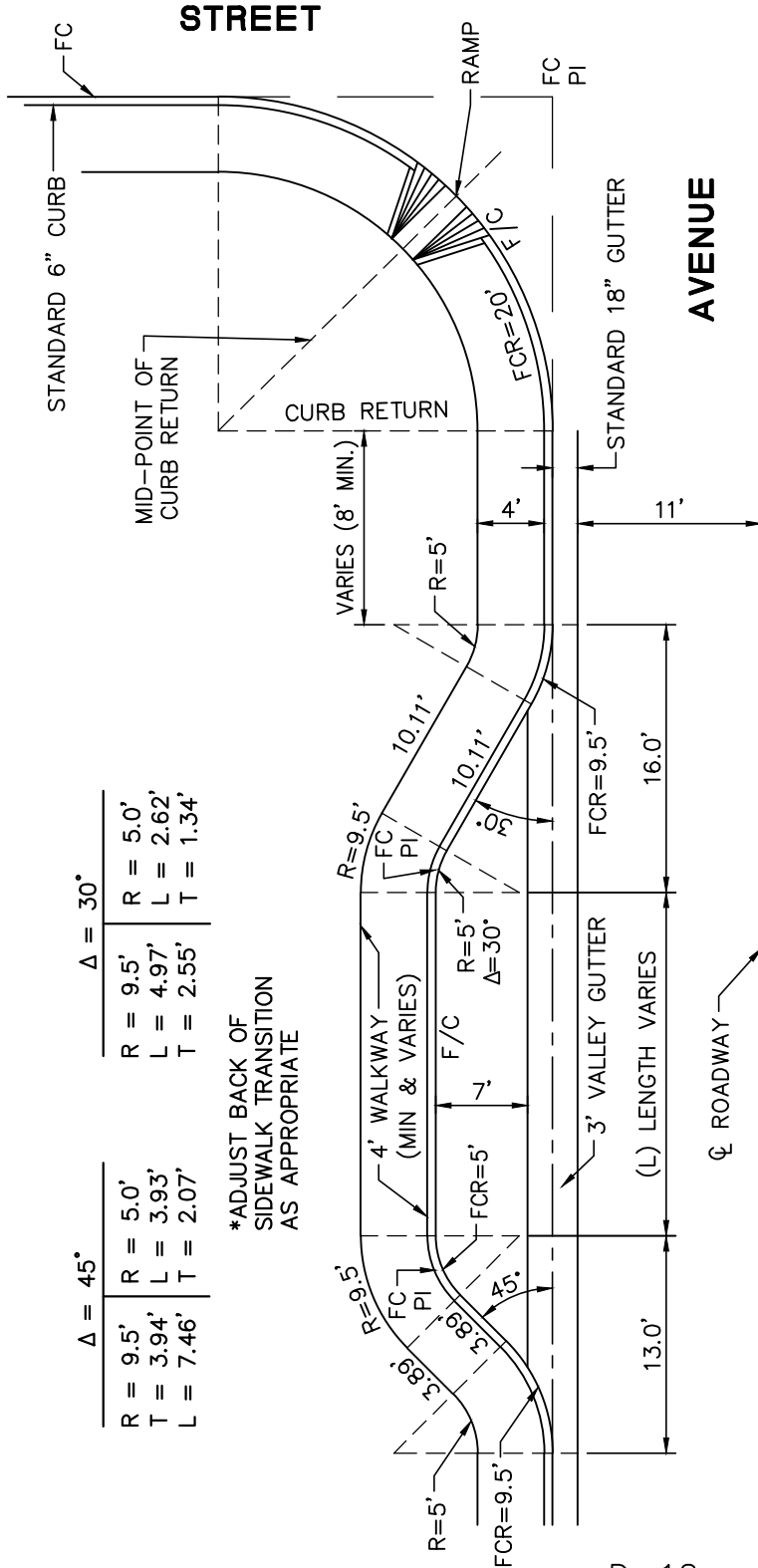

$\Delta = 45^\circ$		$\Delta = 30^\circ$	
R = 9.5'	R = 5.0'	R = 9.5'	R = 5.0'
L = 3.94'	L = 3.93'	L = 4.97'	L = 2.62'
T = 7.46'	T = 2.07'	T = 2.55'	T = 1.34'

\*ADJUST BACK OF  
SIDEWALK TRANSITION  
AS APPROPRIATE

**TYPICAL PARKING BAY (P-2)  
(AT STREET INTERSECTION)**

(NOT FOR USE IN MONTARA/MOSS BEACH)

AREA OF SIDEWALK FROM END OF PARKING BAY TO END OF PARKING BAY (SEE NOTE 1) (FT <sup>2</sup> )	AREA OF CURB FROM END OF PARKING BAY TO END OF PARKING BAY (FT <sup>2</sup> )	AREA OF AC FROM END OF PARKING BAY TO END OF PARKING BAY (FT <sup>2</sup> )	AREA OF VALLEY GUTTER FROM END OF PARKING BAY TO END OF PARKING BAY (FT <sup>2</sup> )	LENGTH OF CURB FROM END OF PARKING BAY TO END OF PARKING BAY (FT)
131.9222+4L	16.49+0.5L	59.506+7L	76.592+3L	32.9804+L

**NOTES:**

1. AREA OF SIDEWALK APPROXIMATION FOR 4' WALKWAY ONLY.
2. "L" MUST BE IN FEET

**COUNTY OF SAN MATEO DEPARTMENT  
OF**

DRAWN BY: A.Z.  
 CHECKED BY: K.L.  
 APPROVED BY: A.M.S.

**PUBLIC WORKS**

.....  
 REDWOOD CITY  
 CALIFORNIA

SCALE: NONE  
 DATE: 2-2022  
 REVISED: 2-2022

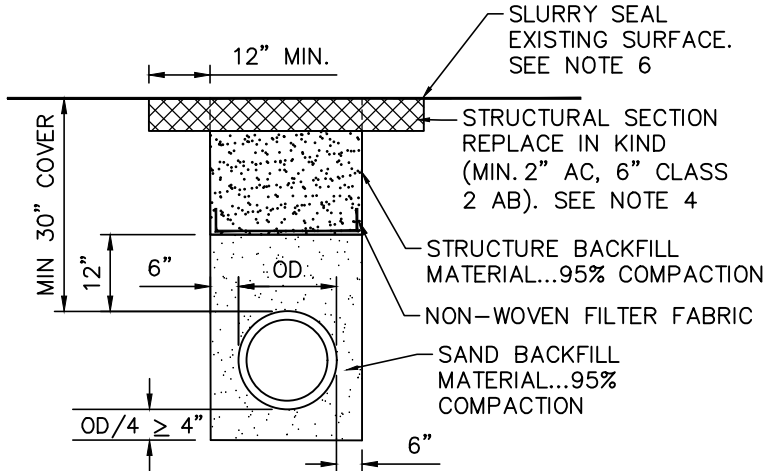

**TYPE A (IN ROADWAY)**

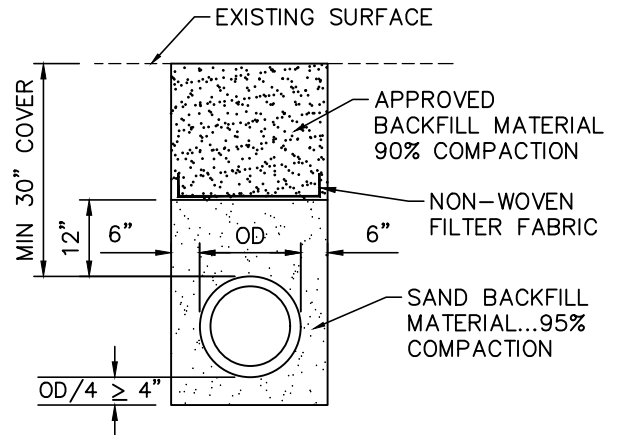

**TYPE B (OUTSIDE ROADWAY)**

**NOTES:**

1. SAND.... MATERIAL FREE FROM ORGANIC MATTER AND CLAY WITH A SIEVE GRADATION BY WEIGHT AS FOLLOWS:

<u>SIEVE SIZE</u>	<u>% PASSING SIEVE</u>
No. 4	100
No. 200	0-5

2. STRUCTURE BACKFILL MATERIAL.... MATERIAL WITH SAND EQUIVALENT NOT LESS THAN 20 AND SIEVE GRADATION BY WEIGHT AS FOLLOWS:

<u>SIEVE SIZE</u>	<u>% PASSING SIEVE</u>
3"	100
No. 4	35-100
No. 200	20-100

3. BACKFILL MATERIAL.... MATERIAL FROM EXCAVATION, FREE FROM STONES OR LUMPS EXCEEDING 3 INCHES GREATEST DIMENSION, ORGANIC MATTER, OR OTHER UNSATISFACTORY MATERIAL.
4. ON TRENCHES THAT PARALLEL THE ROAD AND ARE WITHIN EXISTING BICYCLE LANES, THE WIDTH OF THE STRUCTURAL SECTION SHALL BE GREATER THAN OR EQUAL TO THE WIDTH OF THE EXISTING BICYCLE LANE, WHICHEVER IS WIDER. PAVING JOINTS WITHIN BICYCLE LANES ARE NOT ALLOWED.
5. IF PERMEABLE BACKFILL USED IN PIPE ZONE, NON-WOVEN FILTER FABRIC SHALL BE PLACED AS SHOWN PRIOR TO BACKFILLING ABOVE PIPE ZONE. FILTER FABRIC JOINTS SHALL BE LAPPED 6" LONGITUDINALLY.
6. FULL WIDTH SLURRY SHALL BE APPLIED TO THE FINISH SURFACE FROM EDGE OF PAVEMENT TO EDGE OF PAVEMENT WHEN THERE IS A MAIN OR LATERAL LINE INSTALLATION THAT IS GREATER THAN 100 FEET IN TOTAL LENGTH. SLURRY SEAL SHALL COMPLY WITH CALTRANS STANDARD SPECIFICATIONS. SPREAD RATE TO BE 17 LBS/SY (±1).

**STANDARD TRENCH BACKFILL AND BEDDING DETAIL  
FOR GAS, CABLE, FIBER OPTICS INSTALLATIONS**

COUNTY OF SAN MATEO DEPARTMENT  
OF

PUBLIC WORKS

.....  
REDWOOD CITY  
CALIFORNIA

DRAWN BY: A.Z.  
CHECKED BY: K.L.  
APPROVED BY: A.M.S.

SCALE: NONE  
DATE: 2-2022  
REVISED: 2-2022

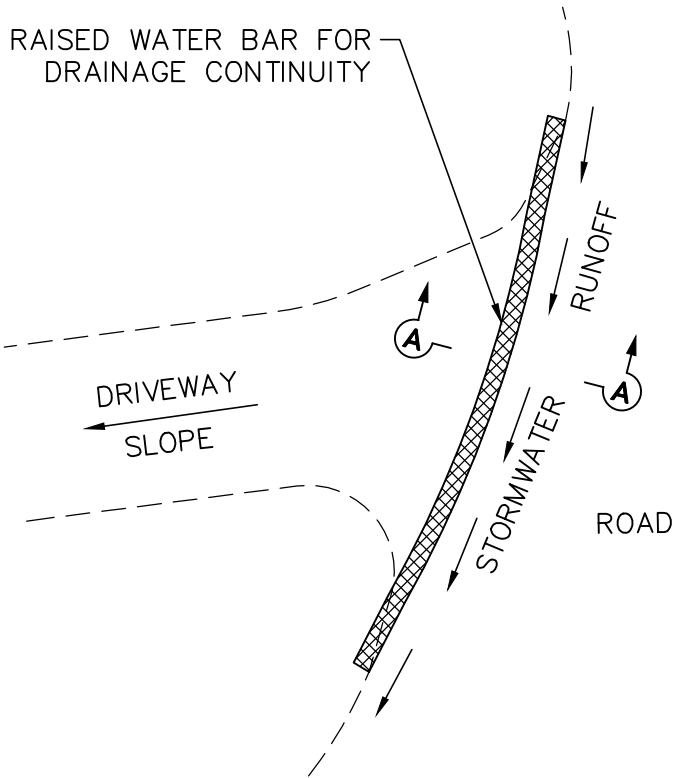

**PLAN**

NOTES:

1. AC WATER BAR MUST BE ROLLED AND COMPACTED WITH A HAND-HELD ROLLER.
2. APPLY ASPHALTIC EMULSION (TYPE SS1) ON EXISTING AC PAVEMENT PRIOR TO INSTALLING AC WATER BAR. ASPHALTIC EMULSION MUST BE APPLIED ON A CLEANED SURFACE.

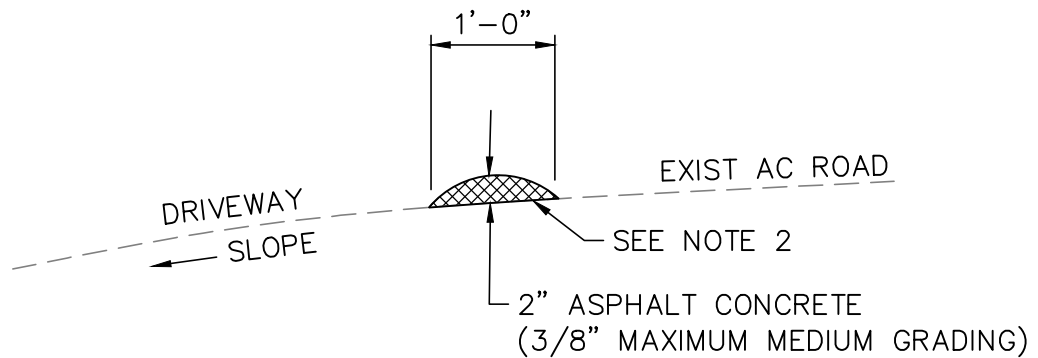

**SECTION A-A**

**AC WATER BAR DETAIL**

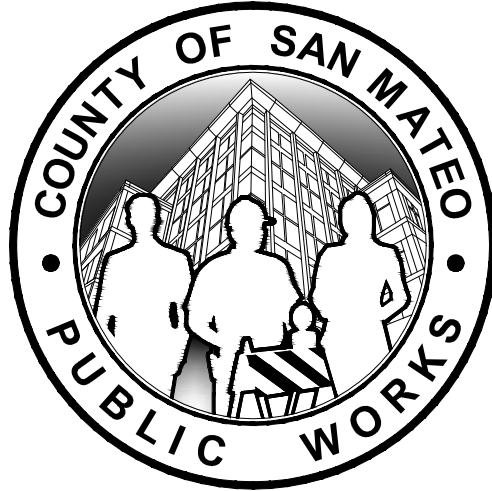

STANDARD DRAWINGS

FOR

PUBLIC IMPROVEMENT

---

**COUNTY  
LIGHTING  
STANDARDS**

**COUNTY OF SAN MATEO DEPARTMENT  
OF**

**PUBLIC WORKS**

.....  
REDWOOD CITY  
CALIFORNIA

DRAWN BY: A.Z.  
CHECKED BY: K.L.  
APPROVED BY: A.M.S.

SCALE: NONE  
DATE: 2-2022  
REVISED: 2-2022

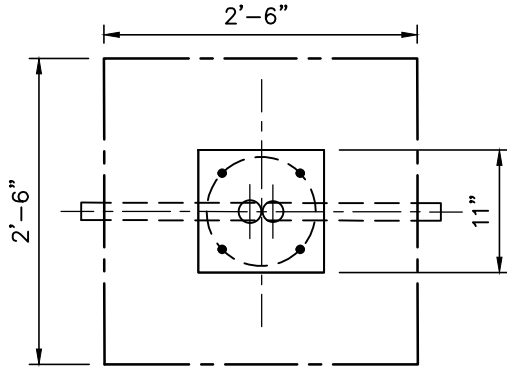

**TOP VIEW**

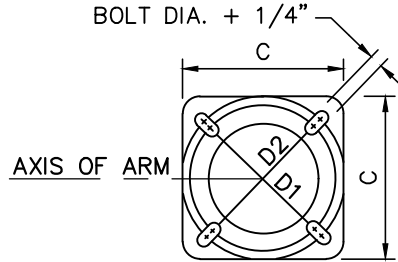

POLE TYPE	BASE PLATE DATA					
	C	D1	D2	THICKNESS	ANCHOR BOLTS	
					SIZE	BOLT CIRCLE
15	12"	11-1/2"	11"	1"	1"x36"x4"	11"

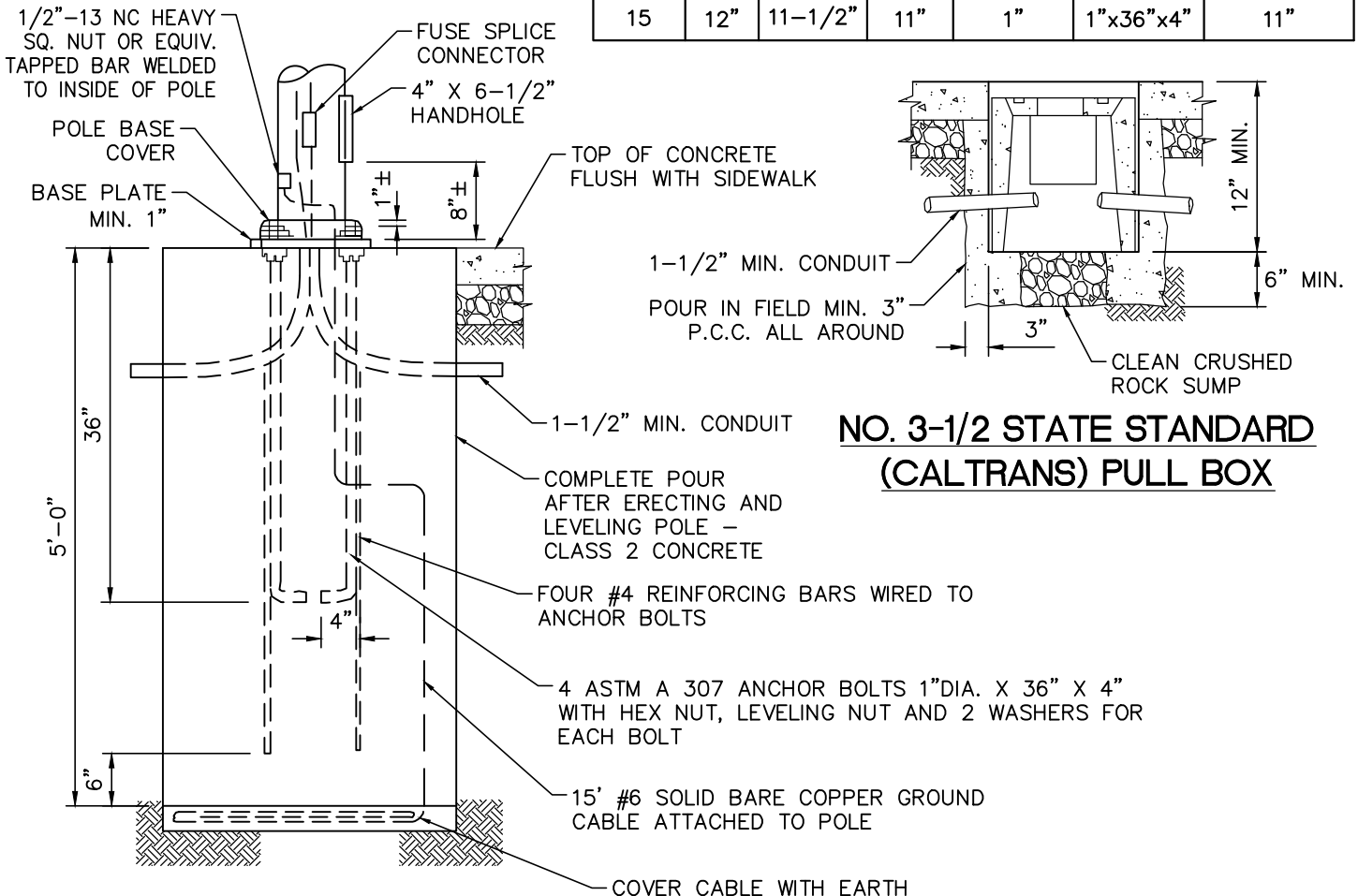

**NO. 3-1/2 STATE STANDARD  
(CALTRANS) PULL BOX**

**STREET LIGHT FOUNDATION**

**COUNTY LIGHTING STANDARD**



**COUNTY OF SAN MATEO DEPARTMENT  
OF  
PUBLIC WORKS**

DRAWN BY: A.Z.  
 CHECKED BY: K.L.  
 APPROVED BY: A.M.S.

.....  
 REDWOOD CITY  
 CALIFORNIA

SCALE: NONE  
 DATE: 2-2022  
 REVISED: 2-2022

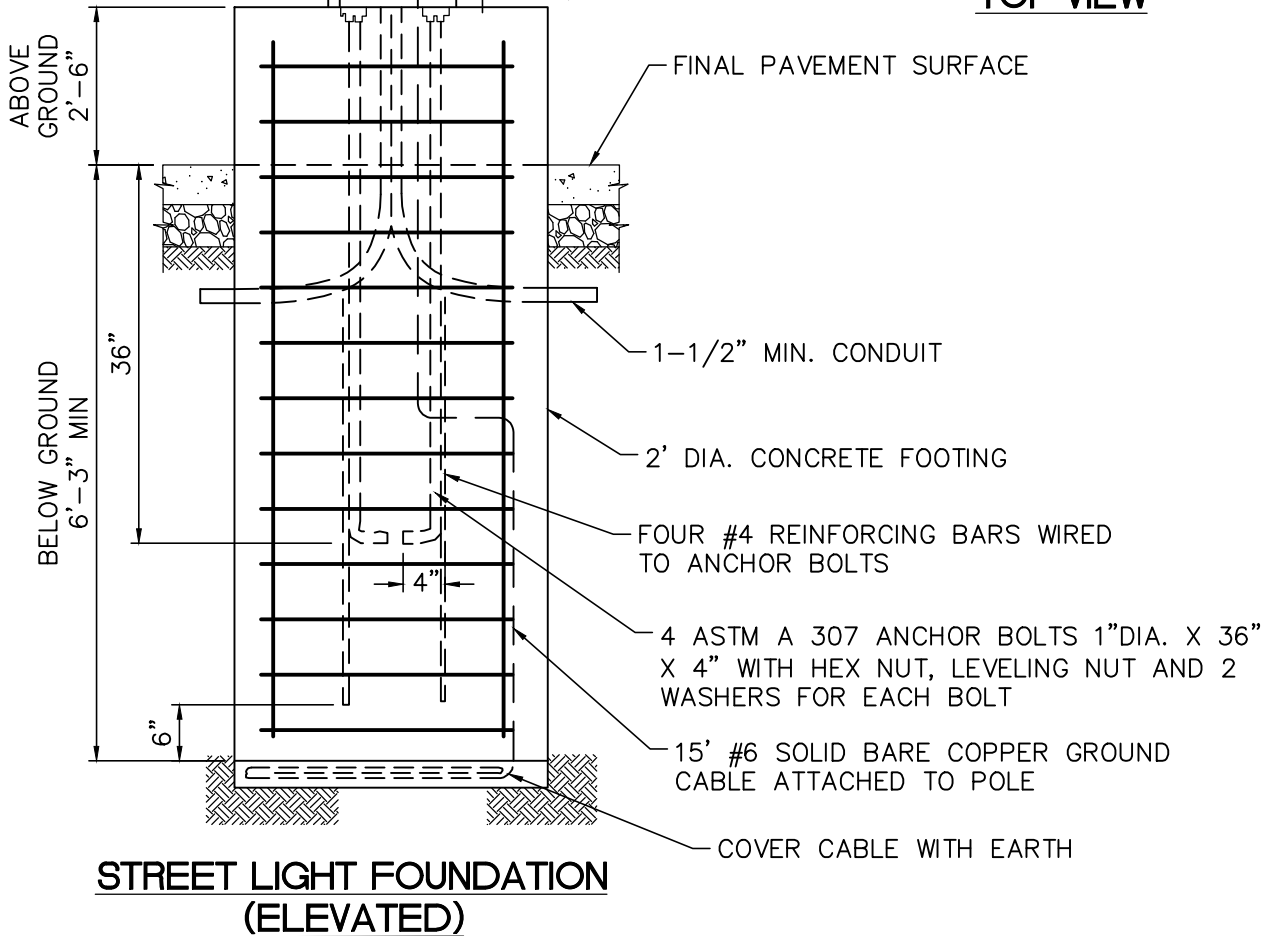
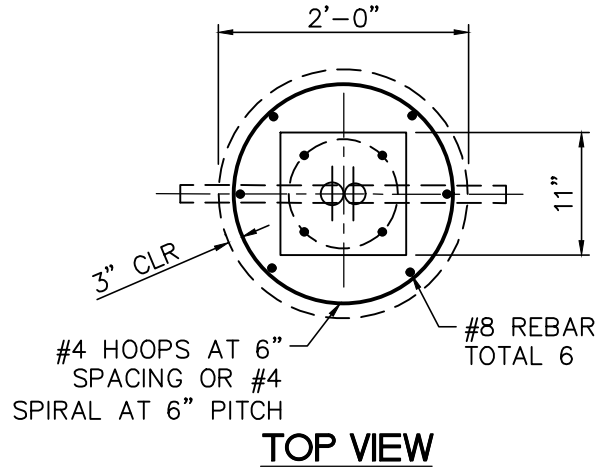
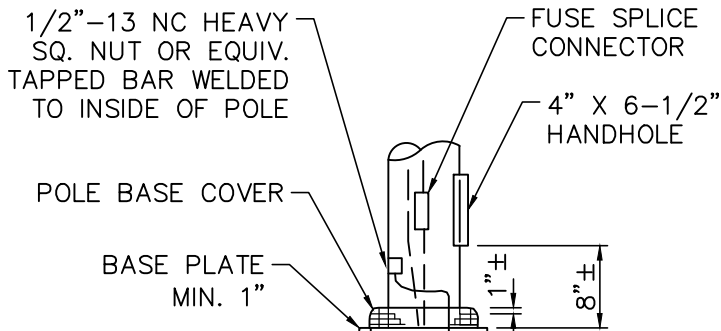

**COUNTY LIGHTING STANDARD**

Sheet 2 of 4

**COUNTY OF SAN MATEO DEPARTMENT  
OF**

DRAWN BY: A.Z.  
 CHECKED BY: K.L.  
 APPROVED BY: A.M.S.

**PUBLIC WORKS**

.....  
 REDWOOD CITY  
 CALIFORNIA

SCALE: NONE  
 DATE: 2-2022  
 REVISED: 2-2022

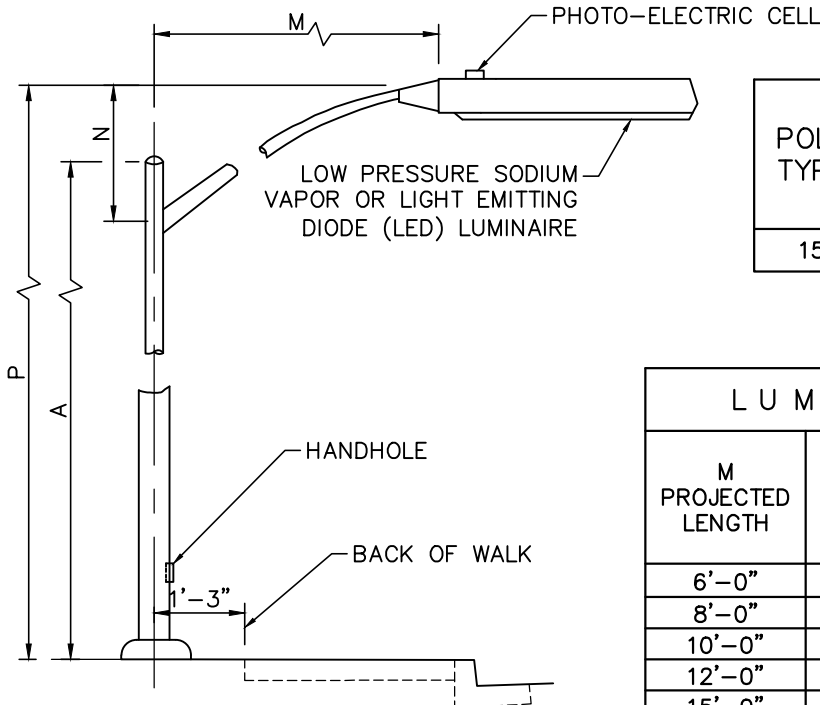

POLE TYPE	P O L E D A T A			
	A HEIGHT	MIN. OD		THICKNESS
		BASE	TOP	
15	30'-0"	8"	3-7/8"	0.1196"

L U M I N A I R E A R M D A T A				
M PROJECTED LENGTH	N RISE	MIN. OD AT POLE	THICKNESS	P MOUNTING HEIGHT
				TYPE 15
6'-0"	2'-0"±	3-1/4"	0.1196"	31'-6"±
8'-0"	2'-6"±	3-1/2"		32'-0"±
10'-0"	3'-3"±	3-7/8"		32'-9"±
12'-0"	4'-3"±	3-7/8"		33'-9"±
15'-0"	4'-9"±	4-1/4"		34'-3"±

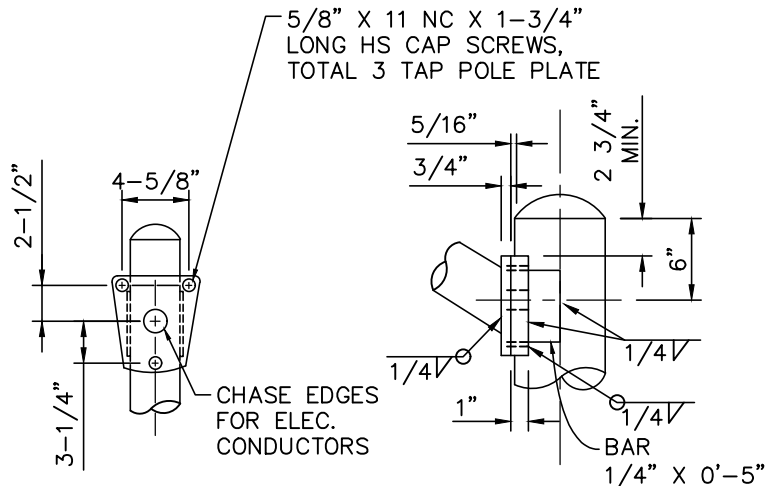
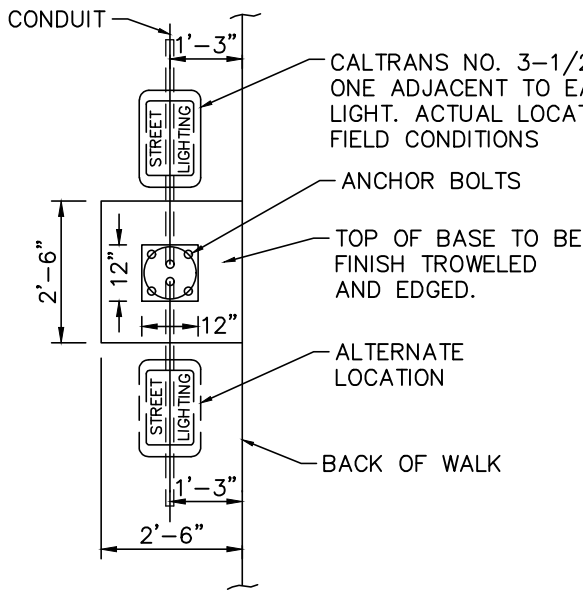

**PLAN**

**PULL BOX LOCATION**

**DETAIL - LUMINAIRE ARM CONNECTION**

**COUNTY LIGHTING STANDARD**

Sheet 3 of 4

**COUNTY OF SAN MATEO DEPARTMENT  
OF**

DRAWN BY: A.Z.  
CHECKED BY: K.L.  
APPROVED BY: A.M.S.

**PUBLIC WORKS**

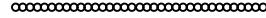

REDWOOD CITY  
CALIFORNIA

SCALE: NONE  
DATE: 2-2022  
REVISED: 2-2022

GENERAL NOTES:

1. LIGHTING STANDARD SHALL BE CALTRANS TYPE 15 AS SPECIFIED IN THE STANDARD SPECIFICATIONS.
2. LIGHTING STANDARD SHALL BE IN PLACE AND TRULY PLUMBED BEFORE PLACING DRY PACK.
3. FOUR ASTM A-307 ANCHOR BOLTS ARE REQUIRED FOR EACH POLE. PROVIDE A HEX NUT, LEVELING NUT AND TWO WASHERS FOR EACH BOLT.
4. LUMINAIRE ARMS SHALL BE ROUND, TAPERED STEEL TUBES.
5. LUMINAIRE SHALL BE LOW PRESSURE SODIUM VAPOR AMERICAN ELECTRIC OR APPROVED EQUAL AND AS SPECIFIED IN THE SPECIAL PROVISIONS OF THE CONTRACT SPECIFICATIONS.
6. ALL LUMINAIRES SHALL BE PROVIDED WITH INDIVIDUAL TYPE IV FISHER PIERCE 105/285V OR APPROVED EQUAL PHOTO-ELECTRIC OUTDOOR LIGHTING CONTROLS, DUAL VOLTAGE 120V-240V INTEGRAL BALLASTS, AND PHILIPS LOW PRESSURE SODIUM VAPOR LAMPS AS SPECIFIED IN THE SPECIAL PROVISIONS OF THE SPECIFICATIONS.
7. LUMINAIRES SHALL BE WIRED TO A "MULTIPLE CIRCUIT".
8. EACH STREET LIGHT STANDARD SHALL BE INSTALLED WITH A CALTRANS NO. 3-1/2 STREET LIGHT PULL BOX, AND A SPLICED-FUSED CONNECTOR.
9. BONDING OF STREET LIGHT STANDARDS SHALL BE BY MEANS OF A BONDING WIRE OR BRAID ATTACHED TO ALL ANCHOR BOLTS.
10. STREET LIGHT FOUNDATION CONCRETE SHALL BE CLASS "2" AS SPECIFIED IN THE STANDARD SPECIFICATIONS.
11. LUMINAIRE WIRING SHALL BE TWO #10 SOLID WIRES (THHN) FROM LUMINAIRE THRU THE SPLICED-FUSED CONNECTOR TO THE STREET LIGHT PULL BOX.
12. THE REFRACTOR OR LENS FOR ALL LUMINAIRES SHALL BE MOULDED PRISMATIC POLYCARBONATE PLASTIC.

**COUNTY LIGHTING STANDARD**

Sheet 4 of 4

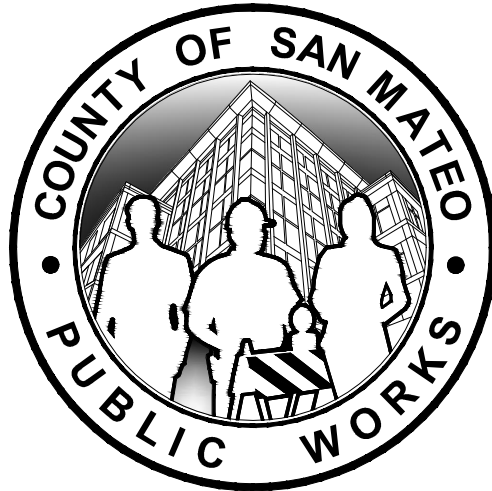

STANDARD DRAWINGS

FOR

PUBLIC IMPROVEMENT

---

**COUNTY  
WATER  
STANDARDS**

**COUNTY OF SAN MATEO DEPARTMENT  
OF**

DRAWN BY: A.Z.  
CHECKED BY: K.L.  
APPROVED BY: A.M.S.

**PUBLIC WORKS**

.....

REDWOOD CITY  
CALIFORNIA

SCALE: NONE  
DATE: 2-2022  
REVISED: 2-2022

**THE FOLLOWING WATER STANDARDS  
ARE APPLICABLE ONLY TO THE FOLLOWING:**

**EAST PALO ALTO COUNTY WATERWORKS DISTRICT**

**COUNTY SERVICE AREA NO. 7  
(LA HONDA)**

**COUNTY SERVICE AREA NO. 11  
( PESCADERO )**

**FOR STANDARDS APPLICABLE TO OTHER AREAS,  
PLEASE CONTACT THE APPROPRIATE JURISDICTION.**

**COUNTY OF SAN MATEO DEPARTMENT  
OF**

**PUBLIC WORKS**

.....  
REDWOOD CITY  
CALIFORNIA

DRAWN BY: A.Z.  
CHECKED BY: K.L.  
APPROVED BY: A.M.S.

SCALE: NONE  
DATE: 2-2022  
REVISED: 2-2022

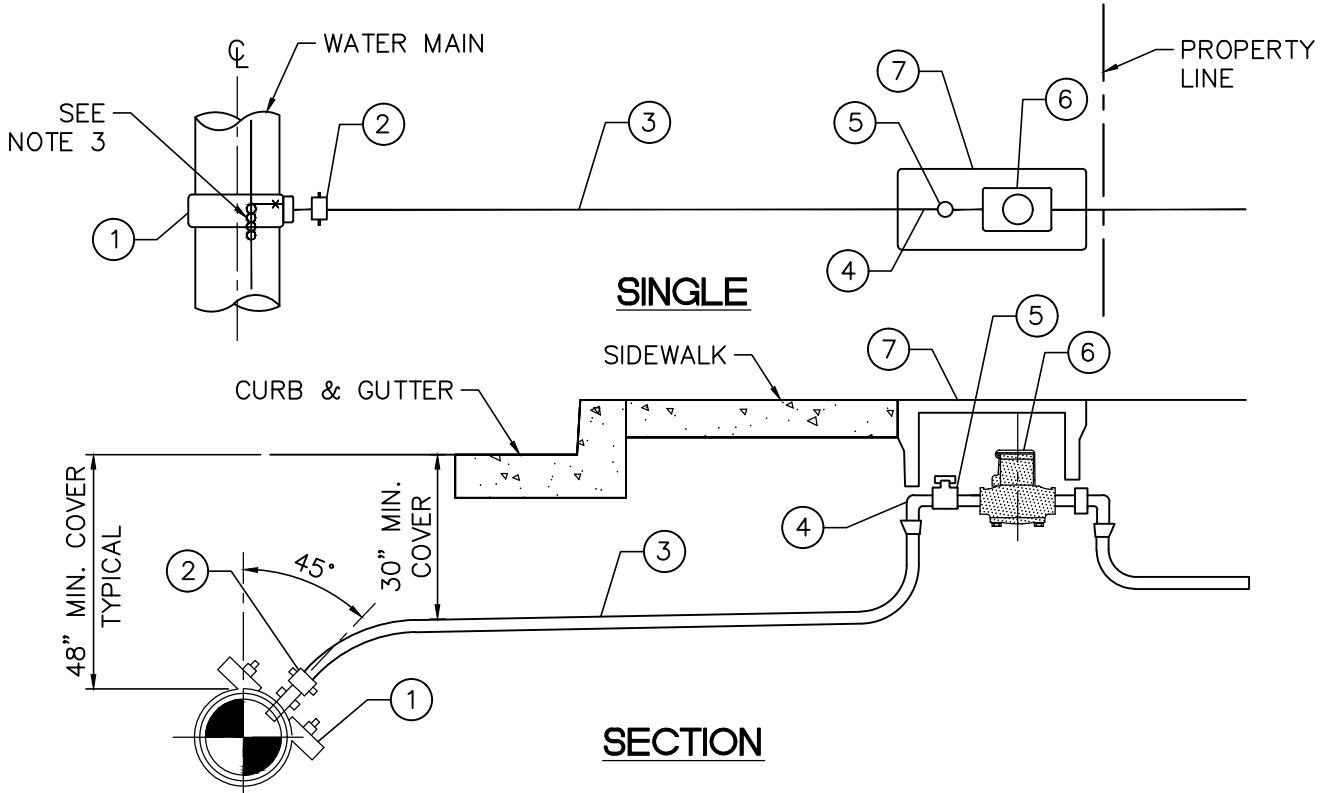

NO.	ITEM	MANUFACTURER & No. AND/OR DESCRIPTION	3/4" SERVICE	SERVICES OVER 3/4"
1	SADDLE	DOUBLE STRAP SADDLE	SEE STANDARD SADDLE REQUIREMENTS	
2	CORB STOP	MUELLER H - 15000	3/4"	AS DETERMINED BY DISTRICT
3	SERVICE PIPE	TYPE K SOFT COPPER	3/4"	
4	1/4 BEND	MUELLER H - 15530	3/4"	
5	CURB STOP	MUELLER H - 10257	3/4"	
6	METER	BY DISTRICT	3/4" X 5/8"	
7	BOX	CHRISTY (BOX : LID)	B-9 : B-9D	

- NOTES:**
1. ITEMS SHADED INSTALLED BY WATER DISTRICT.
  2. FACE OF METER TO BE NO MORE THAN 12 INCHES BELOW LID.
  3. CONNECT TO MAIN LOCATION WIRE, WHERE EXISTING.

**STANDARD SERVICE CONNECTION**

**COUNTY OF SAN MATEO DEPARTMENT  
OF**

DRAWN BY: A.Z.  
 CHECKED BY: K.L.  
 APPROVED BY: A.M.S.

**PUBLIC WORKS**

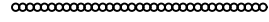

REDWOOD CITY  
CALIFORNIA

SCALE: NONE  
 DATE: 2-2022  
 REVISED: 2-2022

MAIN		TAP SIZE					
TYPE	SIZE	3/4"	1"	1-1/2"	2"	3"	4"
A.C. PIPE	4"	D	D	D	D	X	X
	6"	D	D	D	D	D	X
	8"	D	D	D	D	D	D
	10"	D	D	D	D	D	D
	12"	D	D	D	D	D	D
D.I. PIPE	4"	D	D	D	D	X	X
	6"	D	D	D	D	D	X
	8"	D	D	D	D	D	D
	10"	D	D	D	D	D	D
	12"	D	D	D	D	D	D
P.V.C. PIPE	4"	D	D	D	D	X	X
	6"	D	D	D	D	D	X
	8"	D	D	D	D	D	D
	10"	D	D	D	D	D	D
	12"	D	D	D	D	D	D

X – TAP NOT PERMITTED WITHOUT SPECIAL PERMISSION FROM THE DISTRICT ENGINEER – USE NECESSARY FITTINGS.

D – DOUBLE STRAP SADDLE REQUIRED.

ALL SERVICE SADDLES TO BE OF BRONZE WITH BRONZE STRAPS AND NEOPRENE GASKETS: SMITH BLAIR INC., MUELLER CO., OR APPROVED EQUAL. STAINLESS STEEL MAY BE USED WHEN BRONZE IS UNAVAILABLE.

SADDLES SHALL BE PROPERLY SIZED FOR KIND AND SIZE OF PIPE ACCORDING TO THE MANUFACTURER’S INSTRUCTIONS.

COUNTY OF SAN MATEO DEPARTMENT  
OF

PUBLIC WORKS

.....  
REDWOOD CITY  
CALIFORNIA

DRAWN BY: A.Z.  
CHECKED BY: K.L.  
APPROVED BY: A.M.S.

SCALE: NONE  
DATE: 2-2022  
REVISED: 2-2022

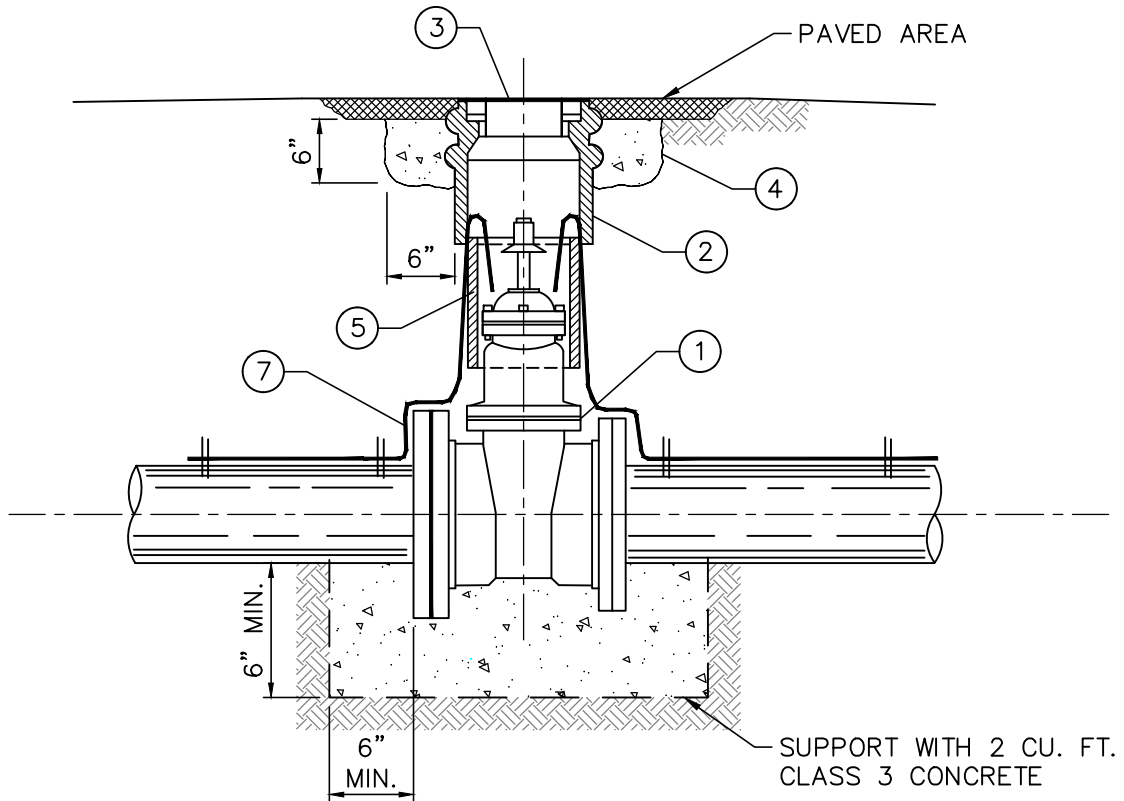

- ① RESILIENT SEAT GATE VALVE: MUELLER A2370 WITH "O"-RING SEALS AND NON-RISING STEM (CCW TO OPEN), OR EQUAL.
- ② VALVE BOX: CHRISTY G5, SET 2" ABOVE GRADE IN NON-TRAFFIC AREAS.
- ③ C.I. COVER, INSCRIBED "WATER"
- ④ CONCRETE SETTING COLLAR IN PAVED AREAS (CLASS 3)
- ⑤ 6" PVC, C900, CL 200 (UNLESS SPECIFIED OTHERWISE BY THE DISTRICT ENGINEER) (LENGTH AS NECESSARY).
- ⑥ ALL BOLTS AND NUTS USED SHALL BE STAINLESS STEEL.
- ⑦ BLUE #10 LOCATION WIRE (WIRE TO EXTEND 1 FOOT ABOVE TOP OF VALVE BOX).

STANDARD GATE VALVE ASSEMBLY



**COUNTY OF SAN MATEO DEPARTMENT  
OF**

**PUBLIC WORKS**

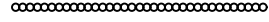

REDWOOD CITY  
CALIFORNIA

DRAWN BY: A.Z.  
CHECKED BY: K.L.  
APPROVED BY: A.M.S.

SCALE: NONE  
DATE: 2-2022  
REVISED: 2-2022

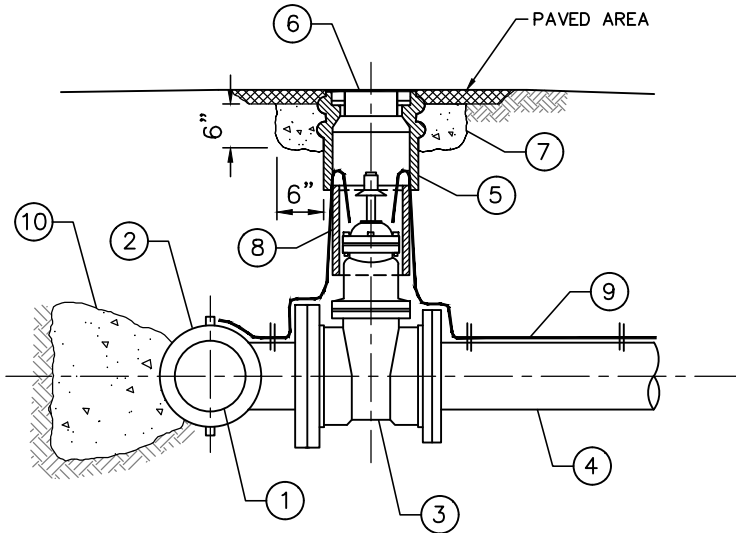

- ① WATER PIPE MAIN (EXISTING)
- ② TAPPING SLEEVE- MUELLER H-619, OR EQUAL
- ③ TAPPING VALVE-MUELLER H-687 OR EQUAL. SIZE SAME AS LATERAL.
- ④ LATERAL, PVC C900, CL-200 (OR AS SPECIFIED BY DISTRICT ENGINEER)
- ⑤ VALVE BOX, CHRISTY G-5, SET 2" ABOVE GRADE IN NON-TRAFFIC AREAS
- ⑥ C.I. COVER, INSCRIBED "WATER"
- ⑦ CONCRETE SETTING COLLAR IN PAVED AREAS (CLASS-3)
- ⑧ 6" PVC PIPE C900 (LENGTH AS NECESSARY)
- ⑨ BLUE #10 LOCATION WIRE (WIRE TO EXTEND 1 FOOT ABOVE TOP OF VALVE BOX)
- ⑩ STANDARD WATER MAIN THRUST BLOCK (SEE W-11)

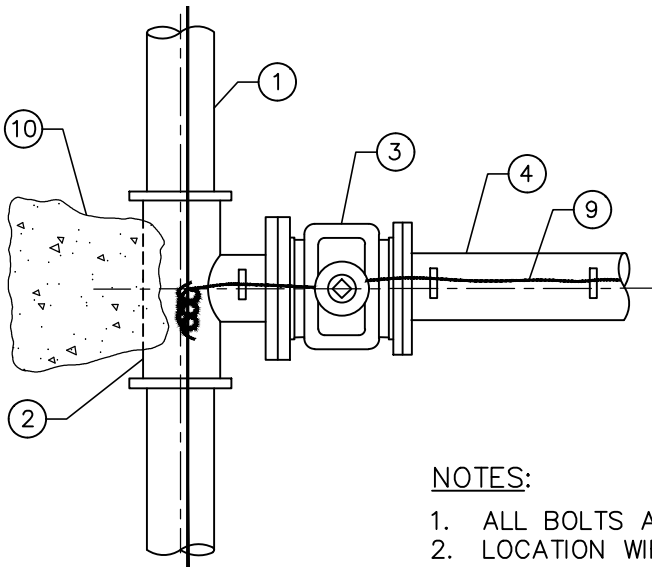

**NOTES:**

- 1. ALL BOLTS AND NUTS USED SHALL BE STAINLESS STEEL.
- 2. LOCATION WIRE TO BE CONNECTED TO MAIN LINE WIRE, WHERE EXISTING.

**STANDARD TAPPING SLEEVE AND  
VALVE ASSEMBLY**

**COUNTY OF SAN MATEO DEPARTMENT  
OF  
PUBLIC WORKS**

DRAWN BY: A.Z.  
CHECKED BY: K.L.  
APPROVED BY: A.M.S.

SCALE: NONE  
DATE: 2-2022  
REVISED: 2-2022

.....  
REDWOOD CITY  
CALIFORNIA

**LOCATION OF FIRE HYDRANT**

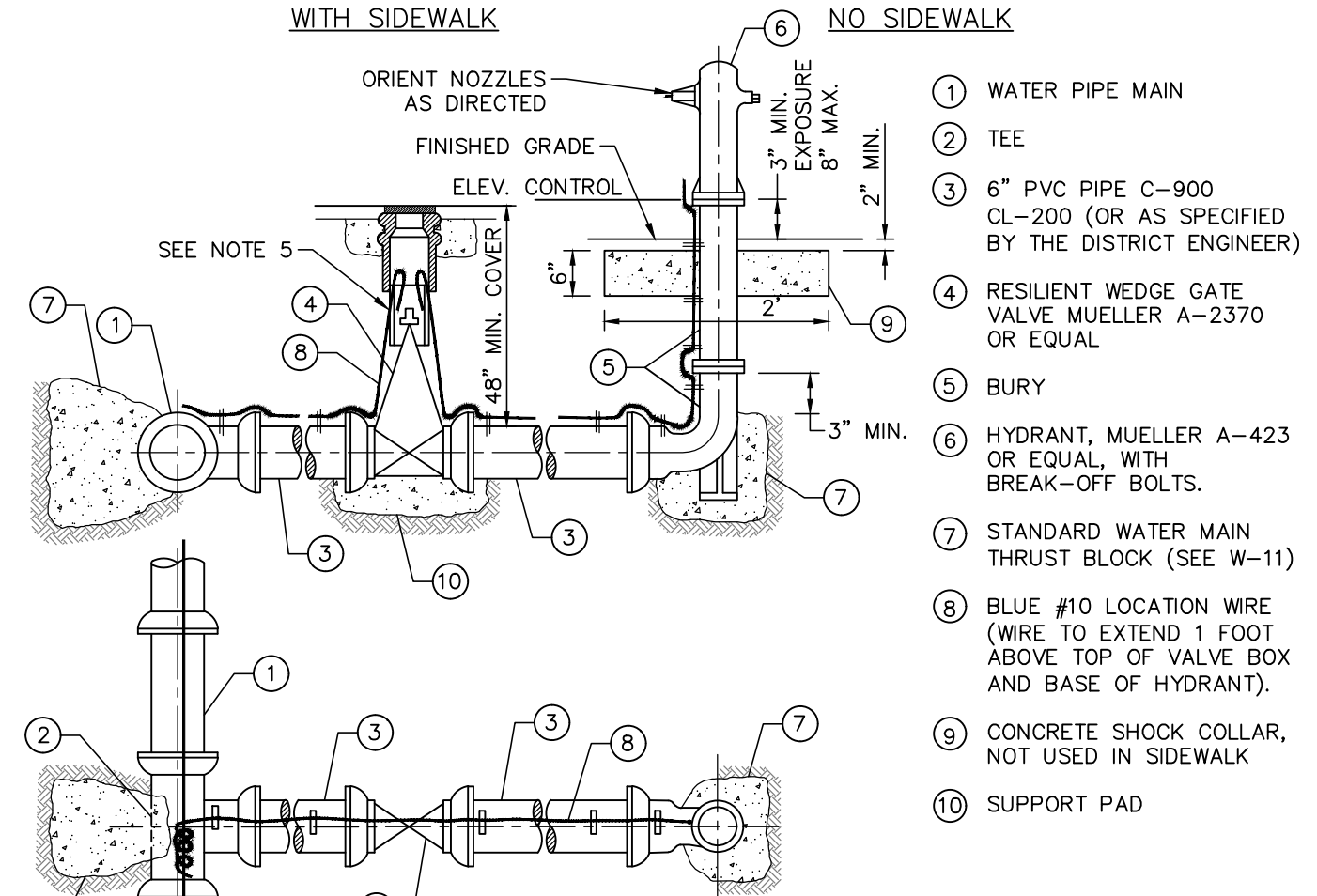
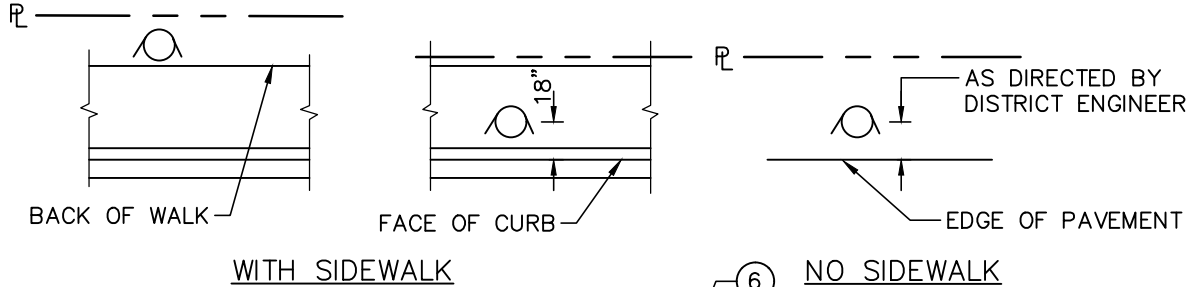

- ① WATER PIPE MAIN
- ② TEE
- ③ 6" PVC PIPE C-900 CL-200 (OR AS SPECIFIED BY THE DISTRICT ENGINEER)
- ④ RESILIENT WEDGE GATE VALVE MUELLER A-2370 OR EQUAL
- ⑤ BURY
- ⑥ HYDRANT, MUELLER A-423 OR EQUAL, WITH BREAK-OFF BOLTS.
- ⑦ STANDARD WATER MAIN THRUST BLOCK (SEE W-11)
- ⑧ BLUE #10 LOCATION WIRE (WIRE TO EXTEND 1 FOOT ABOVE TOP OF VALVE BOX AND BASE OF HYDRANT).
- ⑨ CONCRETE SHOCK COLLAR, NOT USED IN SIDEWALK
- ⑩ SUPPORT PAD

**NOTES:**

1. POUR THRUST BLOCKS AGAINST UNDISTURBED EARTH.
2. PROVIDE MINIMUM 3 CUBIC FEET OF DRAIN ROCK AROUND DRAIN OUTLETS AT FIRE HYDRANTS.
3. ALL BOLTS & NUTS USED SHALL BE STAINLESS STEEL.
4. LOCATION WIRE TO BE CONNECTED TO MAIN LINE WIRE.
5. SEE STANDARD GATE VALVE ASSEMBLY (W-3).

**STANDARD FIRE HYDRANT ASSEMBLY**

**COUNTY OF SAN MATEO DEPARTMENT  
OF  
PUBLIC WORKS**

DRAWN BY: A.Z.  
CHECKED BY: K.L.  
APPROVED BY: A.M.S.

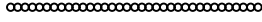

REDWOOD CITY  
CALIFORNIA

SCALE: NONE  
DATE: 2-2022  
REVISED: 2-2022

**LOCATION OF FIRE HYDRANT**

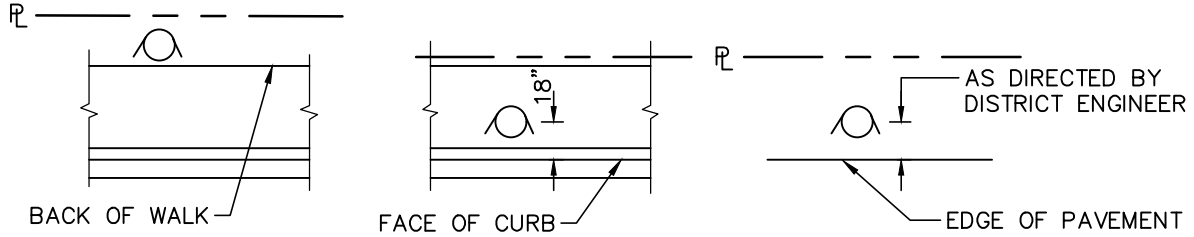

WITH SIDEWALK

NO SIDEWALK

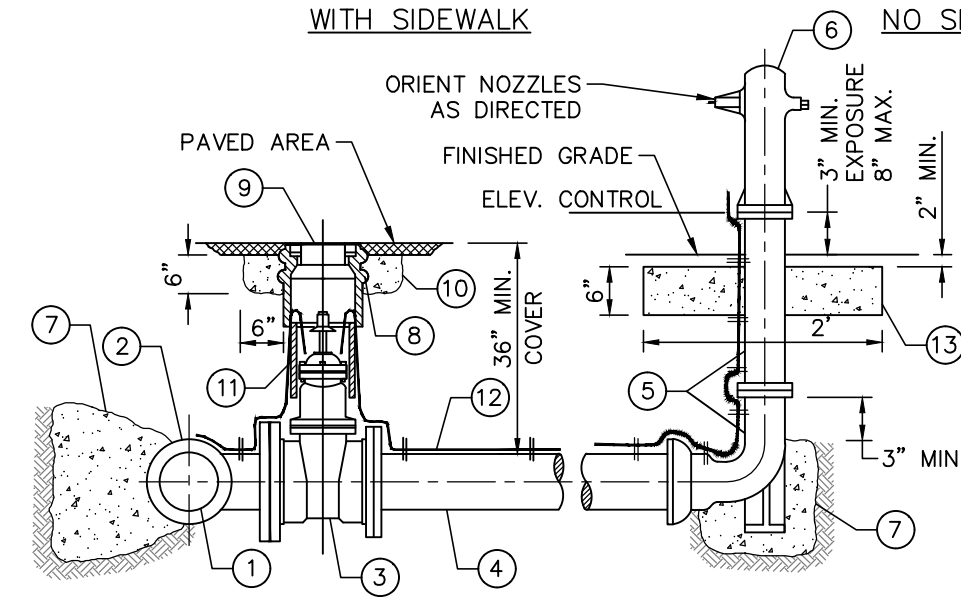

- ① WATER PIPE MAIN
- ② TAPPING SLEEVE—MUELLER H-619, OR EQUAL
- ③ TAPPING VALVE—MUELLER H-687, OR EQUAL
- ④ 6" PVC PIPE C-900 CL-200 (OR AS SPECIFIED BY THE DISTRICT ENGINEER)
- ⑤ BURY
- ⑥ HYDRANT, MUELLER A-423 OR EQUAL, WITH BREAK-OFF BOLTS
- ⑦ THRUST BLOCK (SEE W-11)
- ⑧ VALVE BOX, CHRISTY G5 SET 2" ABOVE GRADE IN NON-TRAFFIC AREAS
- ⑨ C.I. COVER, INSCRIBED "WATER"
- ⑩ CONCRETE SETTING COLLAR IN PAVED AREAS (CLASS 3)
- ⑪ 6" PVC PIPE (LENGTH AS NECESSARY)
- ⑫ BLUE #10 LOCATION WIRE (WIRE TO EXTEND 1 FOOT ABOVE TOP OF VALVE BOX AND BASE OF HYDRANT)
- ⑬ CONCRETE SHOCK COLLAR, NOT USED IN SIDEWALK

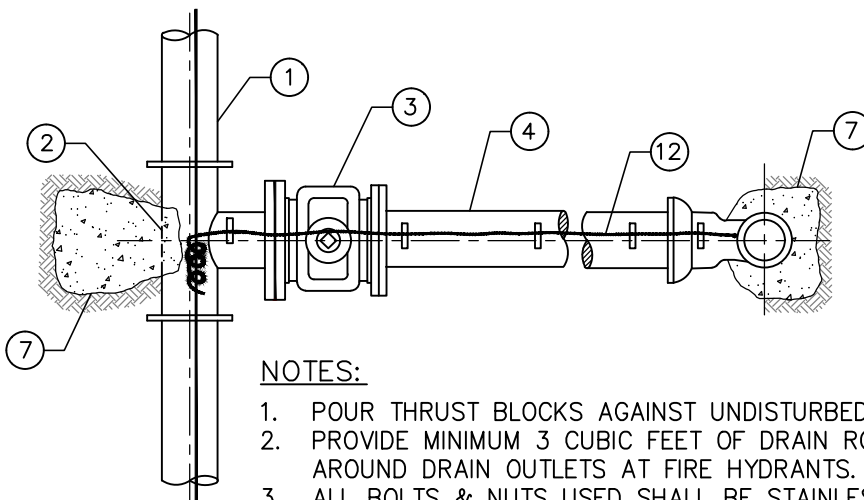

**NOTES:**

- 1. POUR THRUST BLOCKS AGAINST UNDISTURBED EARTH.
- 2. PROVIDE MINIMUM 3 CUBIC FEET OF DRAIN ROCK AROUND DRAIN OUTLETS AT FIRE HYDRANTS.
- 3. ALL BOLTS & NUTS USED SHALL BE STAINLESS STEEL.
- 4. LOCATION WIRE TO BE CONNECTED TO MAIN LINE WIRE.

**TAPPING SLEEVE, VALVE, AND FIRE HYDRANT ASSEMBLY**

COUNTY OF SAN MATEO DEPARTMENT  
OF

PUBLIC WORKS

.....  
REDWOOD CITY  
CALIFORNIA

DRAWN BY: A.Z.  
CHECKED BY: K.L.  
APPROVED BY: A.M.S.

SCALE: NONE  
DATE: 2-2022  
REVISED: 2-2022

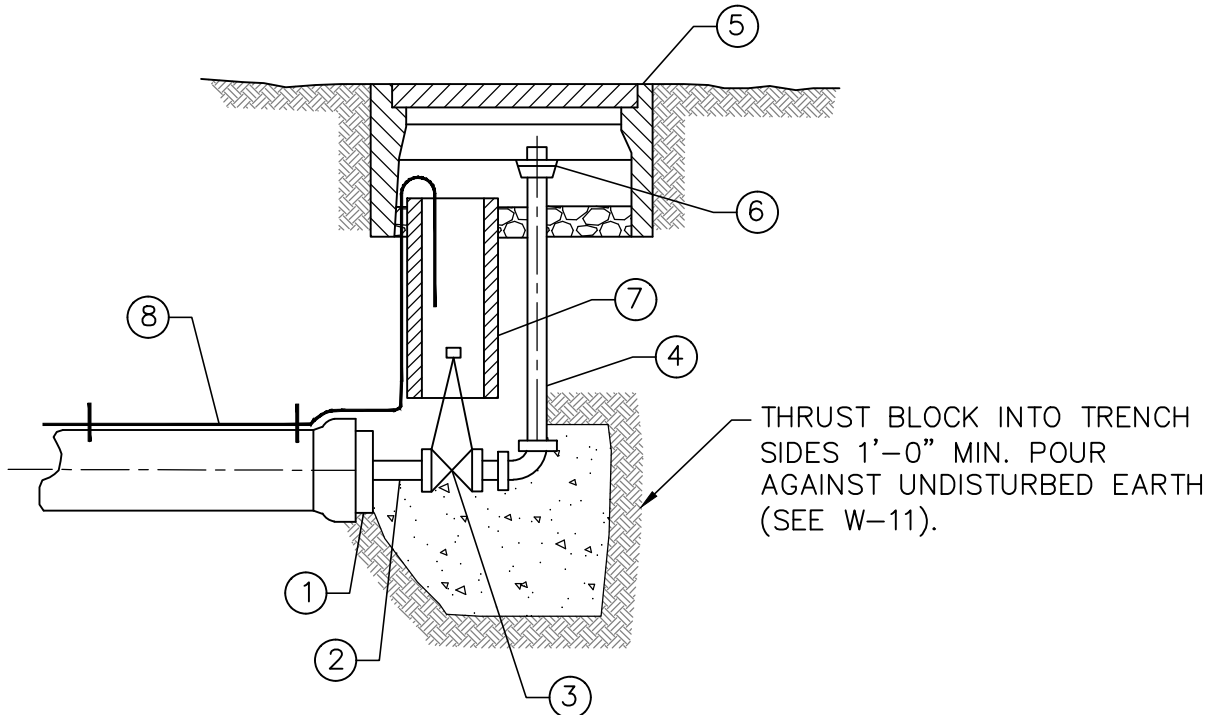

- ① MECHANICAL JOINT TAP CAP WITH ACCESSORIES (C 110). (ALL BOLTS AND NUTS USED SHALL BE STAINLESS STEEL)
- ② 2" BRASS NIPPLE 6" LONG
- ③ 2" MUELLER VALVE NO. H 10915
- ④ 2" BRASS PIPE AND FITTINGS
- ⑤ A. IN NON-TRAFFIC AREAS, USE: CHRISTY NO. B30 METER BOX WITH B30-61D STEEL LID  
B. IN TRAFFIC AREAS, USE: CHRISTY B1730 BOX WITH B1730-51JH STEEL LID
- ⑥ 2-1/2" FIRE HOSE ADAPTER AND CAP
- ⑦ 6" PVC PIPE (LENGTH AS NECESSARY)
- ⑧ BLUE # 10 LOCATION WIRE (WIRE TO EXTEND 1 FOOT ABOVE TOP OF VALVE BOX)

**STANDARD 2" BLOW-OFF ASSEMBLY**

**COUNTY OF SAN MATEO DEPARTMENT  
OF  
PUBLIC WORKS**

DRAWN BY: A.Z.  
 CHECKED BY: K.L.  
 APPROVED BY: A.M.S.

SCALE: NONE  
 DATE: 2-2022  
 REVISED: 2-2022

.....  
 REDWOOD CITY  
 CALIFORNIA

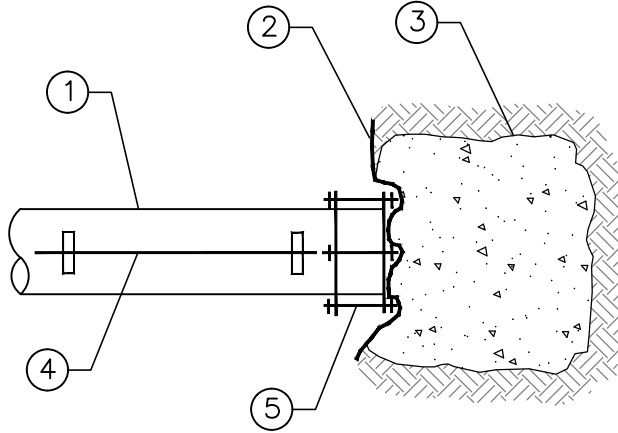

**PLAN**

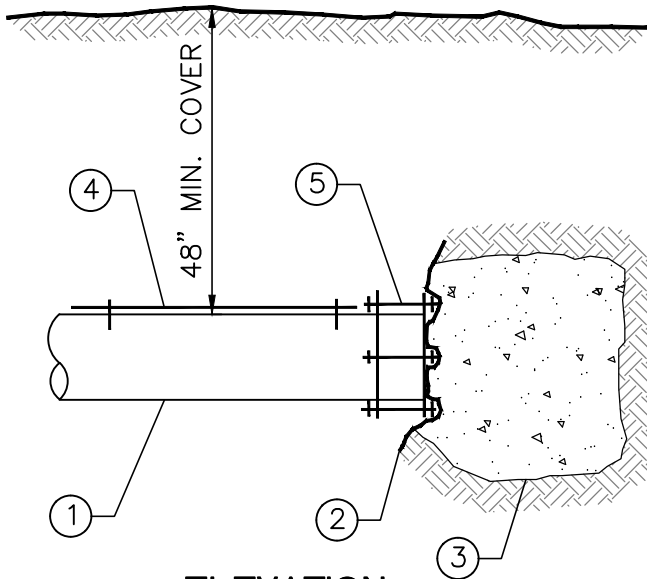

**ELEVATION**

**REMARKS:**

- ① WATER PIPE
- ② 2 LAYERS OF 6 MIL PLASTIC FILM, PLACED BETWEEN THE END CAP AND THRUST BLOCKING
- ③ STANDARD WATER MAIN THRUST BLOCKING (SEE W-11 )
- ④ BLUE # 10 LOCATION WIRE
- ⑤ END CAP, ROCKWELL # 482 OR EQUAL

**NOTES:**

- 1. POUR THRUST BLOCKS AGAINST UNDISTURBED EARTH.
- 2. LOCATION WIRE TO BE CONNECTED TO MAIN LINE WIRE.
- 3. ALL BOLTS AND NUTS USED SHALL BE STAINLESS STEEL.

**DEAD ENDING WATER MAINS**

**COUNTY OF SAN MATEO DEPARTMENT  
OF**

**PUBLIC WORKS**

.....  
REDWOOD CITY  
CALIFORNIA

DRAWN BY: A.Z.  
CHECKED BY: K.L.  
APPROVED BY: A.M.S.

SCALE: NONE  
DATE: 2-2022  
REVISED: 2-2022

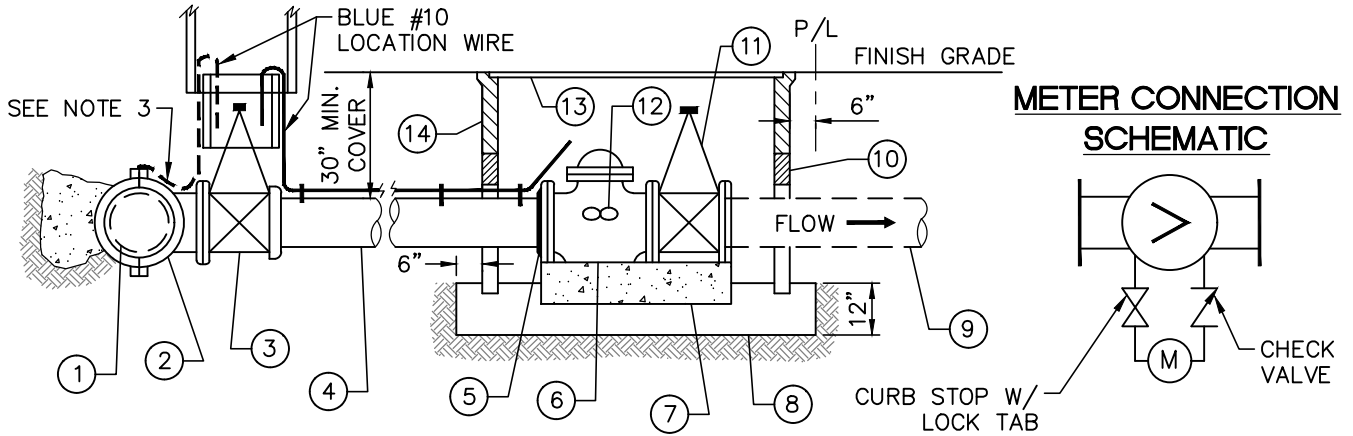

ITEM	6" CHECK	8" CHECK	10" CHECK	> 10" CHECK
① MAIN	AT LEAST 6"	AT LEAST 6"	AT LEAST 10"	CONSULT DISTRICT FOR APPROVAL
② TAPPING SLEEVE	MUELLER H-619, OR EQUAL (SEE W-4)			
③ TAPPING VALVE	MUELLER A-687, OR EQUAL. SIZE EQUAL TO CHECK			
④ PVC C900 CL200	6"	8"	10"	
⑤ FLANGED COUPLING ADAPTER	ROCKWELL TYPE 912, OR EQUAL			
⑥ DETECTOR CHECK VALVE	MUELLER A-2130-6, OR EQUAL, WITH METER			
⑦ 6" CLASS 2 CONCRETE BASE	6"	8"	10"	
⑧ DRAIN ROCK PAD	1-1/2"			
⑨ FIRE LINE	6"	8"	10"	
⑩ EXTENSIONS	2-CHRISTY B40X10	2-CHRISTY B48X10	2-CHRISTY B52X10	
⑪ VALVE	MUELLER A2370, RESILIENT WEDGE SERIES OR EQUAL. SIZE EQUAL TO CHECK			
⑫ METER	5/8" X 3/4"	5/8" X 3/4"	5/8" X 3/4"	
⑬ LID	CHRISTY B40-61G	CHRISTY B48-62G	CHRISTY B52-62G	
⑭ VAULT	CHRISTY B40	CHRISTY B48	CHRISTY B52	

**NOTES:**

1. CENTER METER UNDER READING LID ON COVER.
2. ALL BOLTS AND NUTS SHALL BE STAINLESS STEEL.
3. CONNECT TO MAIN LOCATION WIRE, WHERE EXISTING.
4. FACE OF METER TO BE NO MORE THAN 12 INCHES BELOW LID.

**STANDARD FIRE DETECTOR CHECK ASSEMBLY DETAIL**

**COUNTY OF SAN MATEO DEPARTMENT  
OF**

DRAWN BY: A.Z.  
 CHECKED BY: K.L.  
 APPROVED BY: A.M.S.

**PUBLIC WORKS**



REDWOOD CITY  
CALIFORNIA

SCALE: NONE  
 DATE: 2-2022  
 REVISED: 2-2022

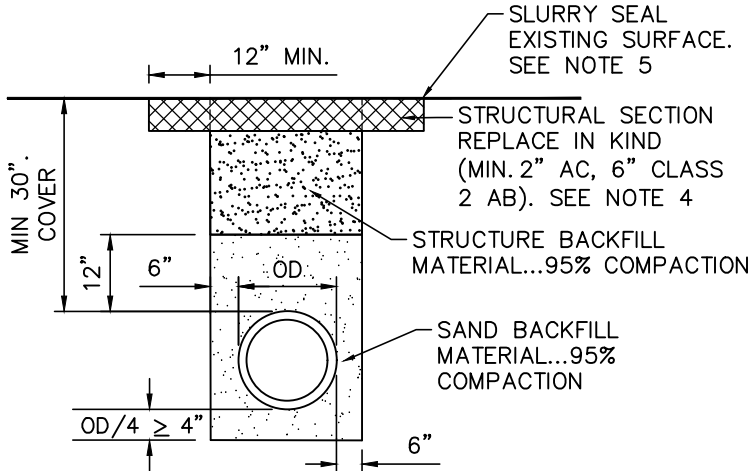

**TYPE A (IN ROADWAY)**

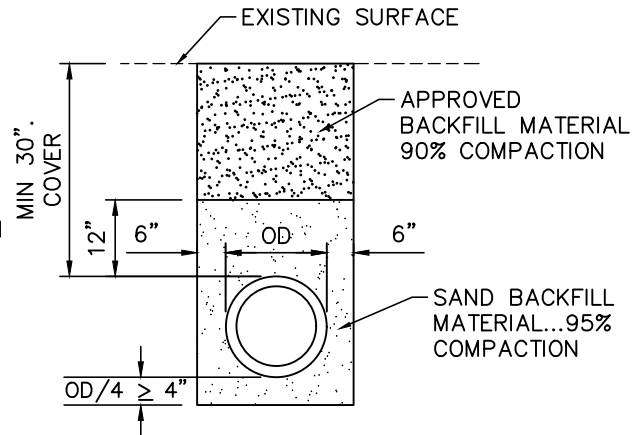

**TYPE B (OUTSIDE ROADWAY)**

**NOTES:**

- SAND.... MATERIAL FREE FROM ORGANIC MATTER AND CLAY WITH A SIEVE GRADATION BY WEIGHT AS FOLLOWS:

SIEVE SIZE	% PASSING SIEVE
No. 4	100
No. 200	0-5

- STRUCTURE BACKFILL MATERIAL.... MATERIAL WITH SAND EQUIVALENT NOT LESS THAN 20 AND SIEVE GRADATION BY WEIGHT AS FOLLOWS:

SIEVE SIZE	% PASSING SIEVE
3"	100
No. 4	35-100
No. 200	20-100

- BACKFILL MATERIAL.... MATERIAL FROM EXCAVATION, FREE FROM STONES OR LUMPS EXCEEDING 3 INCHES GREATEST DIMENSION, ORGANIC MATTER, OR OTHER UNSATISFACTORY MATERIAL.
- ON TRENCHES THAT PARALLEL THE ROAD AND ARE WITHIN EXISTING BICYCLE LANES, THE WIDTH OF THE STRUCTURAL SECTION SHALL BE GREATER THAN OR EQUAL TO THE WIDTH OF THE EXISTING BICYCLE LANE, WHICHEVER IS WIDER. PAVING JOINTS WITHIN BICYCLE LANES ARE NOT ALLOWED.
- FULL WIDTH SLURRY SHALL BE APPLIED TO THE FINISH SURFACE FROM EDGE OF PAVEMENT TO EDGE OF PAVEMENT WHEN THERE IS A MAIN OR LATERAL LINE INSTALLATION THAT IS GREATER THAN 100 FEET IN TOTAL LENGTH. SLURRY SEAL SHALL COMPLY WITH CALTRANS STANDARD SPECIFICATIONS. SPREAD RATE TO BE 17 LBS/SY (±1).

**STANDARD TRENCH BACKFILL AND BEDDING DETAIL  
FOR WATER LINE INSTALLATIONS**

**COUNTY OF SAN MATEO DEPARTMENT  
OF**

DRAWN BY: A.Z.  
 CHECKED BY: K.L.  
 APPROVED BY: A.M.S.

**PUBLIC WORKS**

.....  
 REDWOOD CITY  
 CALIFORNIA

SCALE: NONE  
 DATE: 2-2022  
 REVISED: 2-2022

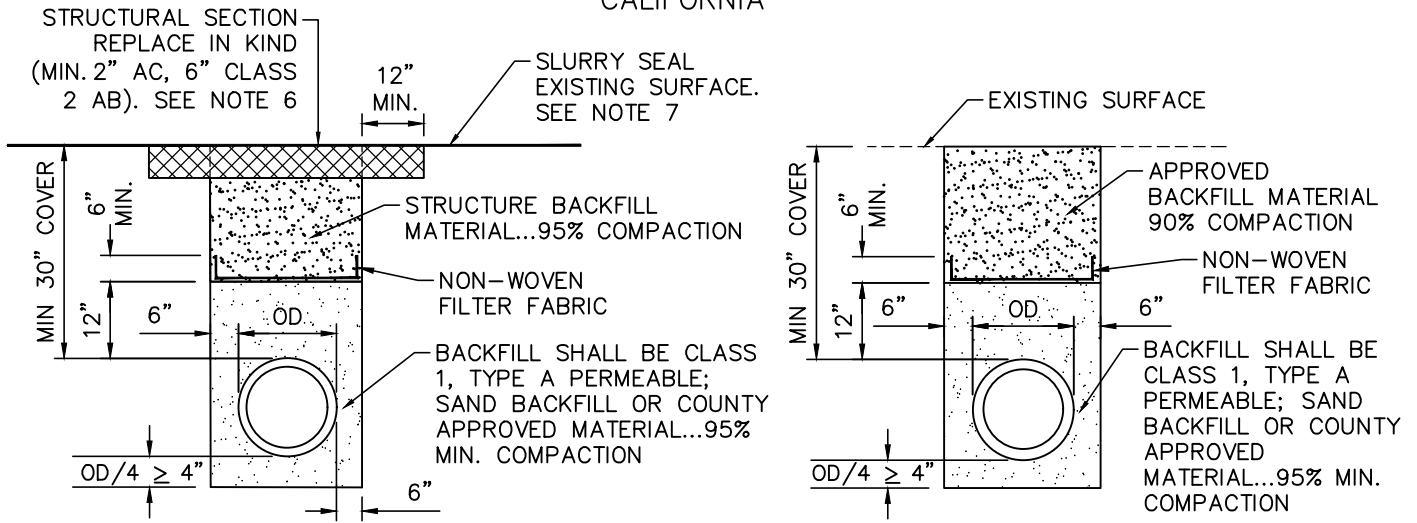

**TYPE A (IN ROADWAY OR SHOULDER)**

**TYPE B (OUTSIDE ROADWAY)**

**NOTES:**

1. SAND.... MATERIAL FREE FROM ORGANIC MATTER AND CLAY WITH A SIEVE GRADATION BY WEIGHT AS FOLLOWS:

<u>SIEVE SIZE</u>	<u>% PASSING SIEVE</u>
No. 4	100
No. 200	0-5

2. STRUCTURE BACKFILL MATERIAL.... MATERIAL WITH SAND EQUIVALENT NOT LESS THAN 20 AND SIEVE GRADATION BY WEIGHT AS FOLLOWS:

<u>SIEVE SIZE</u>	<u>% PASSING SIEVE</u>
3"	100
No. 4	35-100
No. 200	20-100

3. BACKFILL MATERIAL.... MATERIAL FROM EXCAVATION, FREE FROM STONES OR LUMPS EXCEEDING 3 INCHES GREATEST DIMENSION, ORGANIC MATTER, OR OTHER UNSATISFACTORY MATERIAL.
4. IF PERMEABLE BACKFILL USED IN PIPE ZONE, NON-WOVEN FILTER FABRIC SHALL BE PLACED AS SHOWN PRIOR TO BACKFILLING ABOVE PIPE ZONE. FILTER FABRIC JOINTS SHALL BE LAPPED 6" LONGITUDINALLY.
5. FOR INSTALLATIONS UNDER SIDEWALK SAWCUTS SHALL OCCUR AT SCORE MARKS OR CONSTRUCTION JOINTS. WHERE SERVICE LINE IS LOCATED WITHIN 6" OF SCORE LINE OR JOINTS, 2 SECTIONS OF SIDEWALK SHALL BE SAWCUT AND REPLACED IN KIND.
6. ON TRENCHES THAT PARALLEL THE ROAD AND ARE WITHIN EXISTING BICYCLE LANES, THE WIDTH OF THE STRUCTURAL SECTION SHALL BE GREATER THAN OR EQUAL TO THE WIDTH OF THE EXISTING BICYCLE LANE, WHICHEVER IS WIDER. PAVING JOINTS WITHIN BICYCLE LANES ARE NOT ALLOWED.
7. FULL WIDTH SLURRY SHALL BE APPLIED TO THE FINISH SURFACE FROM EDGE OF PAVEMENT TO EDGE OF PAVEMENT WHEN THERE IS A MAIN OR LATERAL LINE INSTALLATION THAT IS GREATER THAN 100 FEET IN TOTAL LENGTH. SLURRY SEAL SHALL COMPLY WITH CALTRANS STANDARD SPECIFICATIONS. SPREAD RATE TO BE 17 LBS/SY (±1).

**STANDARD TRENCH BACKFILL AND BEDDING DETAIL  
FOR REDWOOD CITY WATER LINE INSTALLATIONS**



**COUNTY OF SAN MATEO DEPARTMENT  
OF**

**PUBLIC WORKS**

.....  
REDWOOD CITY  
CALIFORNIA

DRAWN BY: A.Z.  
CHECKED BY: K.L.  
APPROVED BY: A.M.S.

SCALE: NONE  
DATE: 2-2022  
REVISED: 2-2022

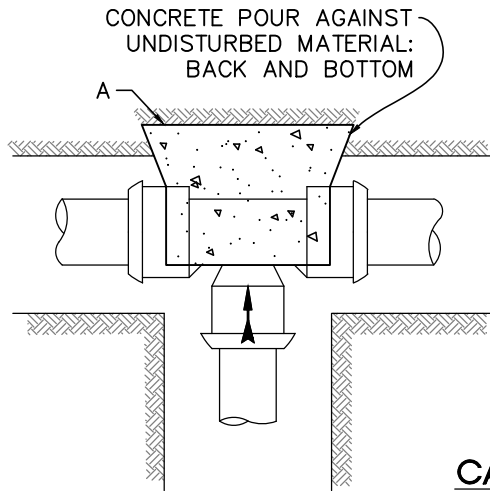

**CASE A**

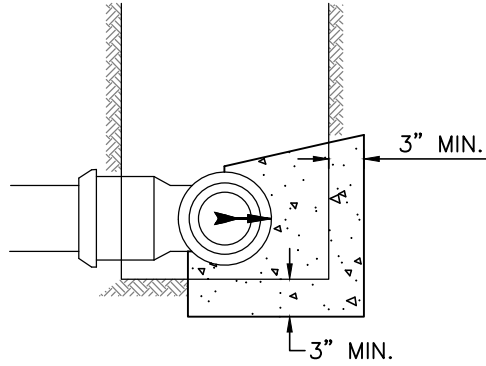

**CASE B**

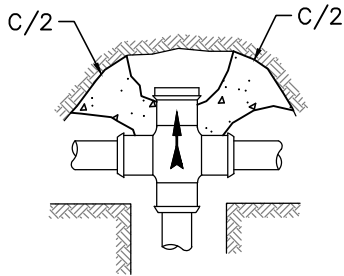
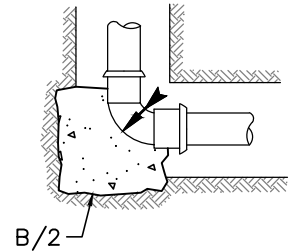

**CASE C**

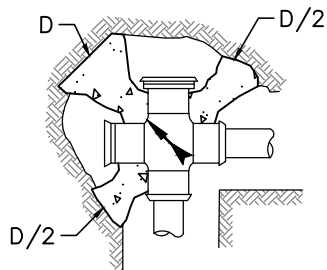

**CASE D**

(LARGEST MAIN GOVERNS)

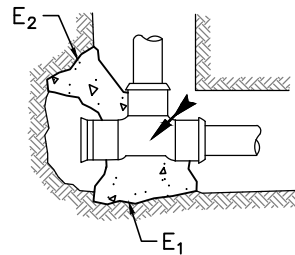

**CASE E**

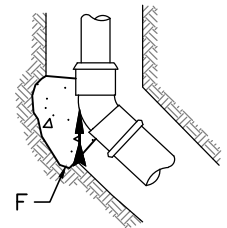

**CASE F**

**NOTES:**

1. CASE "A" IS TYPICAL FOR ALL.
2. ALL BLOCKS TO BE KEPT CLEAR OF LUGS.
3. UNSUPPORTED SURFACES TO BE FORMED.
4. ARROWS ON CASE "A", "C" & "E" INDICATE MAINS WHICH DETERMINE BEARING AREA.
5. BASED ON 150 P.S.I. PRESSURE, 1,000 P.S.F. SOIL BEARING.
6. CONCRETE SHALL BE CLASS B PER STANDARD SPECIFICATIONS.

REQUIRED BEARING AREAS – SQ. FT.

	A	B	C	D	E <sub>1</sub>	E <sub>2</sub>	F
4"	2	3	3	3	2	3	2
6"	5	6	7	7	5	7	4
8"	8	12	11	11	8	11	6
10"	12	18	17	17	12	17	8
12"	17	24	24	24	17	24	12

**STANDARD WATER MAIN THRUST BLOCK**

COUNTY OF SAN MATEO DEPARTMENT  
OF

PUBLIC WORKS

.....  
REDWOOD CITY  
CALIFORNIA

DRAWN BY: A.Z.  
CHECKED BY: K.L.  
APPROVED BY: A.M.S.

SCALE: NONE  
DATE: 2-2022  
REVISED: 2-2022

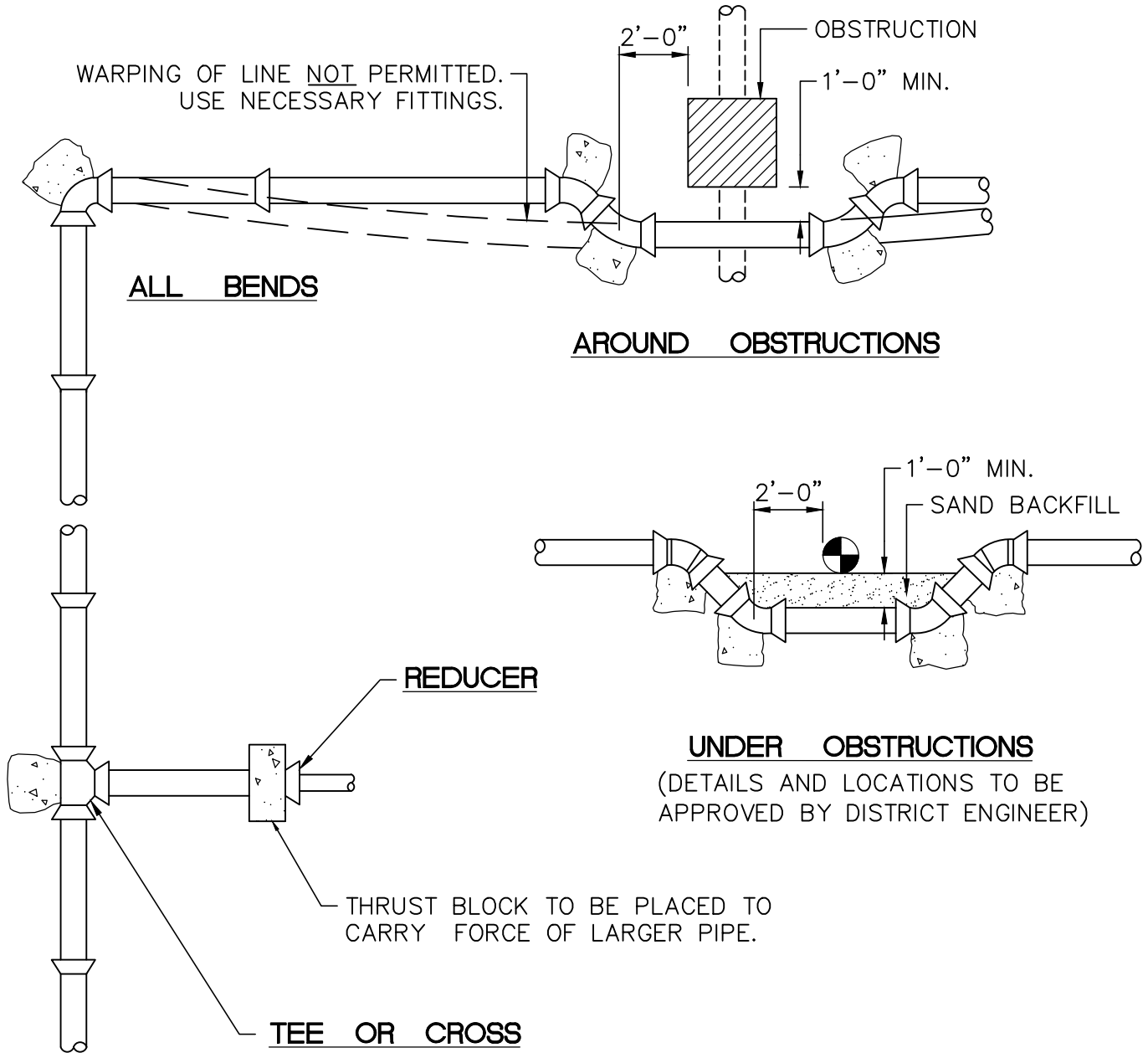

NOTE: IF FLANGED FITTINGS ARE SPECIFIED, USE  
STAINLESS STEEL BOLTS AND NUTS.

STANDARD PIPE INSTALLATION DETAILS

**COUNTY OF SAN MATEO DEPARTMENT  
OF**

DRAWN BY: A.Z.  
 CHECKED BY: K.L.  
 APPROVED BY: A.M.S.

**PUBLIC WORKS**

.....  
 REDWOOD CITY  
 CALIFORNIA

SCALE: NONE  
 DATE: 2-2022  
 REVISED: 2-2022

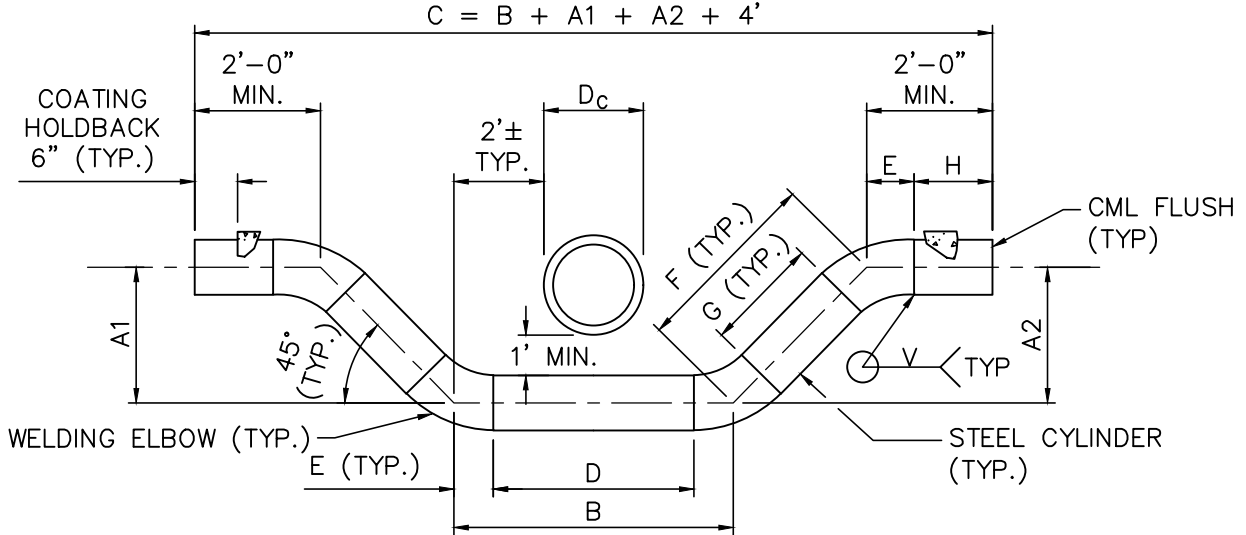

NOMINAL SIZE	STEEL CYLINDER		E	CML	CMC
	SIZE	SCHEDULE			
6"	6"	40	3.75"	3/8"	3/4"
8"	8"	20	5.00"	3/8"	3/4"
10"	10"	20	6.25"	1/2"	3/4"
12"	14"	10	8.75"	1/2"	3/4"

A's	B	C	D	F's	G's	H
A1, A2	4'+D <sub>c</sub>	4'+A1+A2+B	B-2E	F1=A1/0.707 F2=A2/0.707	G1=F1-2E G2=F2-2E	2'-E

**NOTES:**

- IT WILL BE THE RESPONSIBILITY OF THE CONTRACTOR TO EXPOSE AND VERIFY THE ELEVATIONS AND GRADIENTS OF THE PIPE. LOCATION OF EXISTING JOINTS, THRUST BLOCKS, AND ANY OTHER DIMENSION NECESSARY FOR THE PREPARATION, FABRICATION AND INSTALLATION OF THE DOUBLE OFFSET.
- FABRICATION AND INSTALLATION OF THE DOUBLE OFFSET SHALL BE IN ACCORDANCE WITH APPLICABLE AMERICAN WATERWORKS ASSOCIATION (AWWA) STANDARDS AND THESE SPECIAL DETAILS.
- CEMENT MORTAR LINING (CML) AS PER AWWA C205-85.
- CEMENT MORTAR COATED (CMC) AS PER AWWA C205-85. USE 14 GAUGE WIRE REINFORCING, SPIRALLY WOUND AND EMBEDDED IN CENTER OF COATING.
- USE ASTM A-234, GRADE B, WELDING FITTINGS, TO BE SAME SCHEDULE AS STEEL CYLINDER.
- STEEL COUPLINGS AND FITTINGS USED FOR CONNECTIONS SHALL BE FUSION BONDED, EPOXY COATED, PER AWWA C213-85.

**STANDARD FABRICATED DOUBLE OFFSET DETAIL**