

**COUNTY OF SAN MATEO
PLANNING AND BUILDING DEPARTMENT**

DATE: December 5, 2024

TO: Zoning Hearing Officer

FROM: Planning Staff

SUBJECT: Consideration of a Coastal Development Permit, Use Permit, and Design Review Permit, pursuant to Sections 6328.4, 6287.0, and 6565.3 of the San Mateo County Zoning Regulations, to allow a proposed 4,900 sq. ft. boat storage building on a 10,500 sq. ft. legal parcel. The project requires minimal grading and no tree removal. The project site is located at 166 California Avenue in the unincorporated Princeton area of San Mateo County. The project is appealable to the California Coastal Commission.

County File Number: PLN 2024-00035 (Falvey/French)

PROPOSAL

The applicant proposes a 4,900 sq. ft. prefabricated metal building for boat storage on a 10,500 sq. ft. legal parcel located at 166 California Avenue in the unincorporated Princeton area. The storage building will include a single-occupant restroom and 64 sq. ft. closet on the inside, two bay doors on the front, a pitched metal roof, and 3 onsite parking stalls. Stormwater runoff will be contained through an onsite infiltration-based retention feature. The project requires minimal grading and no tree removal. No boat assembly, repair, sales, or outdoor storage is proposed. The project site is an undeveloped lot used as an outdoor storage yard. Items stored onsite have been removed and the yard is currently vacant. The lot has some existing asphalt and is graveled throughout with an existing 6-foot-tall chain link fence, with tan colored vinyl slats, around the perimeter of the property. Access to the property is from California Avenue through existing rolling gates.

RECOMMENDATION

That the Zoning Hearing Officer approve the Coastal Development Permit, Use Permit, and Design Review Permit, County File Number PLN2024-00035, by adopting the required findings and conditions of approval contained in Attachment A.

BACKGROUND

Report Prepared By: Luis Topete, Project Planner III

Applicant: Bryan Falvey

Owner: Arthur T. French and Thelma V. French, Trustees of the French Family Trust dated May 9, 2013

Public Notification: Ten-day advanced notification for the hearing was mailed to all property owners and residents within 300 feet of the perimeter of the project parcel and a notice for the hearing was posted in newspaper San Mateo County Times of general public circulation.

Location: 166 California Avenue, in the unincorporated Princeton area

APN: 047-021-200

Size: 10,500 sq. ft.

Existing Zoning: Waterfront District/Design Review District/Coastal Development District (W/DR/CD)

General Plan/Local Coastal Program Designation: General Industrial

Sphere-of-Influence: City of Half Moon Bay

Existing Land Use: The project site is an undeveloped lot permitted (PLN1999-00370) as an outdoor storage yard for a tree cutting service.

Water Supply: Coastside County Water District

Sewage Disposal: Granada Community Services District

Flood Zone: Zone X (Areas of Minimal Flood Hazard). FEMA Community Panel 06081C0138F. Effective Date: August 2, 2017.

Hazard Zone: Tsunami and Seiche Inundation Area

Environmental Evaluation: The project is categorically exempt from the California Environmental Quality Act (CEQA), pursuant to CEQA Guidelines Section 15303, Class 3, relating to the construction and location of limited numbers of new, small facilities or structures.

Setting: The undeveloped subject property is located on the north side of California Avenue, north of the intersection of Yale Avenue and California Avenue within the unincorporated Princeton-by-the-Sea area. No trees or undisturbed areas are present on the subject parcel. There are existing trees on the neighboring properties near the southwest and southeastern corner of the parcel. The parcel is relatively flat, with the average slope across the property being 2 percent. The site drains as sheet-flow to the south to a concrete drainage swale alongside California Avenue. The concrete swale directs runoff to the south end of Broadway, where it flows over an armored embankment into the harbor.

Land uses in the surrounding area consist of self-storage buildings adjacent to the project site on the east and west, the Half Moon Bay Airport immediately to the north, with an undeveloped lot, outdoor storage yards, industrial, and non-conforming residential uses across the street to the south.

Chronology:

<u>Date</u>	<u>Action</u>
October 7, 1999	- Use Permit and Coastal Development Permit approved to by the ZHO to allow outdoor storage for a tree cutting service.
August 17, 2000	- Recordation of merger (PLN2000-00576) of the 3 lots constituting the subject site.
February 1, 2024	- Application submitted.
September 17, 2024	- Application deemed complete.
October 31, 2024	- Certificate of Compliance (Type A) recorded.
December 5, 2024	- Zoning Hearing Officer public hearing.

DISCUSSION

A. KEY ISSUES

1. Conformance with the County General Plan

Staff has determined that the project complies with all applicable General Plan Policies, including:

a. Visual Quality

Policy 4.36 (*Urban Area Design Concept*) seeks to maintain and improve upon the appearance and visual character of development in

urban areas, and to ensure that new development is designed and constructed to contribute to the orderly and harmonious development of the locality. The proposed structure is a prefabricated metal building with outdoor wall mounted lights that are dark sky compliant. The project proposes a color palette of darker shades, including gray, black, and brown. The building design fits the industrial style that exists in Princeton and will blend well with the overall neighborhood appearance. The proposed project will introduce a new development into the neighborhood that is compatible and complementary to the existing mix of architectural styles and will be an overall improvement to the site and the area.

b. General Land Use

Policy 7.15 (*Designation of Land Uses*) and Policy 7.16 (*Land Use Objectives for Urban Areas*) seek to apply land use designations where appropriate to urban areas and establish primary associated uses for the land use designations to meet land use objectives for urban areas that includes revitalization of existing developed areas. The project parcel's land use designation is General Industrial which supports boat storage. The project site is in the Waterfront Zoning District which allows for commercial establishments primarily engaged in storage of marine vessels as an allowed use, subject to the issuance of a use permit.

c. Urban Land Use Policies

Policy 8.24 (*Land Use Compatibility*), Policy 8.36 (*Uses*), and Policy 8.40 (*Parking Requirements*) seek to ensure that: industrial development is compatible with adjacent land uses; uses are consistent with the overall land use designation; and minimum on-site parking requirements and parking development standards accommodate the parking needs of the development, provide convenient and safe access, prevent congestion of public streets, and establish orderly development patterns. Land uses in the surrounding area consist of self-storage buildings adjacent to the project site on the east and west, the Half Moon Bay Airport immediately to the north, with an undeveloped lot, outdoor storage yards, industrial and non-conforming residential uses across the street to the south. The proposed boat storage use is compatible with adjacent land uses that would serve local residents and coastside visitors by offering a marine-related service consistent with the General Industrial land use designation and Waterfront Zoning District. Additionally, the project requires a minimum of two onsite parking spaces with three spaces proposed. The project complies with the minimum onsite parking requirement.

2. Conformance with the Local Coastal Program (LCP)

A Coastal Development Permit is required pursuant to LCP Policies 1.1 (*Coastal Development Permits*) and 1.2 (*Definition of Development*). Staff has reviewed the project against the applicable policies of the LCP and has summarized the sections most relevant to this project below.

a. Locating and Planning New Development

Policy 1.4 (*Designation of Urban Areas*) designates as urban those lands shown inside the urban/rural boundary on the Land Use Plan Maps. Such areas include Montara, Moss Beach, El Granada, Princeton-by-the-Sea and Miramar. The project site is located in Princeton-by-the-Sea, in the urban boundary and designated for urban use.

Policy 1.18 (*Location of New Development*) directs new development to existing urban areas in order to: (1) discourage urban sprawl, (2) maximize the efficiency of public facilities, services, and utilities; (3) protect and enhance the natural environment; (4) revitalize existing developed areas, and; (5) concentrate new development in urban areas by requiring the “infilling” of existing commercial areas. The project site is an undeveloped lot located in a developed urban area adjacent to developed lots. The parcel is within an area served by public water, sewer, gas, and electric. The parcel is currently used as outdoor storage with no trees or undisturbed areas present on the subject parcel.

Policy 1.19 (*Ensure Adequate Public Services and Infrastructure for New Development in Urban Areas*) prohibits the approval of permits for development in the urban area unless it can be demonstrated that it will be served with adequate water supplies and wastewater treatment facilities. A referral was sent to the Coastside County Water District (CCWD) and. CCWD is currently serving this parcel and did not indicate any issues with continued water allocation, subject to the project’s compliance with CCWD’s regulations on water service and metering. The Granada Community Services District indicated that there is a sewer mainline facility available to serve the proposed project and if the subject parcel conforms in size with the County’s zoning requirements, the applicant may submit a sewer permit application after receiving County Planning approval. The parcel’s Waterfront zoning district requires a minimum building site of 5,000 square feet. The subject parcel is 10,500 sq. ft. in size. All new construction projects require a sewer connection permit, and the

applicant will be required to submit the construction plans with their sewer permit application form and other items. Comments provided by the CCWD and GCSO have been incorporated as conditions of approval.

Policy 1.36 (*Half Moon Bay Airport Influence Area Requirements*) requires development to comply with all relevant Federal Aviation Administration (FAA) standards and criteria regarding (1) safety, (2) flashing lights (3) reflective material (4) land uses which might involve large concentration of birds, (5) HVAC exhaust fans, and (6) land uses which may generate electrical or electronic interference with aircraft communications and/or instruments. According to the City/County Association of Governments of San Mateo County (C/CAG) Airport Land Use Compatibility Plan (ALUCP) for the Half Moon Bay Airport, the project site is predominantly in the Half Moon Bay Airport safety Zone 2 -Inner Approach/Departure Zone (IADZ), with a small portion of the northeast corner of the site in safety Zone 3 - Inner Turning Zone (ITZ). The project was found to be in compliance with the Safety Criteria Matrix found in Table 4B of the ALUCP, including not exceeding the 35 feet height threshold that would trigger an airspace review. The proposed building will be 30 feet-5 inches in height. Further, the project site is outside of the defined aircraft noise exposure contours and would therefore not be exposed to high levels of aircraft noise.

b. Visual Resources

Policy 8.12 (*General Regulations*) requires the application of the Design Review (DR) Zoning District to urban areas in the Coastal Zone and for new development to be located and designed so that ocean views are not blocked from public viewing points. The proposed project is in the DR Zoning District and has been found to be compliant with the design standards contained in Section 6565.17 of the Zoning Regulations. Further, the project will not block ocean views from public viewing points.

Policy 8.13 (*Special Design Guidelines for Coastal Communities*) encourages industrial development in the Princeton-by-the-Sea area to employ architectural detailing, subdued colors, textured building materials, and landscaping to add visual interest and soften the harsh lines of standard or stock building forms normally used in industrial districts. The proposed structure is a prefabricated metal building with outdoor wall mounted lights that are dark sky compliant. The project proposes a color palette of darker shades, including gray, black, and brown. The building design fits the industrial style that exists in Princeton and will blend well with the overall neighborhood

appearance. The project proposes 4-foot-wide landscaped planters adjacent to California Avenue. The proposed project will introduce a new development into the neighborhood that is compatible and complementary with the existing mix of architectural styles and will be an overall improvement to the site and the area.

c. Hazards

Policy 9.1 (*Definition of Hazard Areas*) defines hazardous areas as fault zones and land subject to dangers from liquefaction and other severe seismic impacts, unstable slopes, landslides, coastal cliff instability, flooding, tsunamis, fire, and steep slopes (over 30 percent). The project site is mapped as being within the tsunami and seiche inundation area. The project was reviewed by the County's Geotechnical Section with conditions added to Attachment A.

Policy 9.3 (*Regulation of Geologic Hazard Areas*) requires the application of certain regulations of the Resource Management Zoning Ordinance to designated hazard areas. The proposed project has been found to be compliant with the "Hazards to Public Safety Criteria" contained in Section 6324.6 and the "Tsunami Inundation Area Criteria" contained in Section 6326.2 of the Zoning Regulations. No noxious chemical, petroleum or other flammable liquids, or other potentially hazardous materials will be stored or manufactured onsite. Further, no uses, structures, and development identified as unpermitted in Section 6326.2 are proposed.

d. Commercial Fishing/Recreational Boating

Policy 12.3 (*Related Uses*) encourages development or uses which directly support recreational boating or commercial fishing before all others within one-half mile of the Pillar Point Harbor area on lands designated on the Land Use Plan maps in Commercial Recreation or General Industrial. The Land Use Plan map designations the subject parcel as General Industrial. The subject parcel is located within one-half mile of the Pillar Point Harbor area and the proposed use of the parcel is boat storage.

3. Conformance with the Zoning Regulations

The project is located in the Waterfront District. This District defines "Boat Building, Repair, Sales and Support Establishments" as commercial establishments primarily engaged in the assembly, repair, storage, or sale of marine vessels and support services including, but not limited to, the sale of fuel. Projects falling under this land use definition are permitted uses in the Water District, subject to the approval of a use permit.

- a. Development Standards: The following analyses detail the project's compliance with relevant development standards of the Waterfront District. There is no maximum floor area ratio or minimum setbacks for the Waterfront District.
- Minimum Building Site. Each building site must have an area of not less than 5,000 sq. ft. and a width of not less than 50 feet. The lot area is 10,500 sq. ft., and the lot width is 105 feet.
 - Building Height Limit. The maximum building height is 36 feet. A building height of 30 feet-5 inches is proposed.
 - Lot Coverage. Not more than 60 % of the building site may be covered by buildings. A lot coverage of 47 % is proposed.
 - Landscaping. Landscaping must be provided in parking areas in accordance with Section 6121(a)1 and 4 of the Zoning Regulations. As the project does not propose more than 10 vehicle parking stalls, nor is it adjacent to a residentially zoned parcel, the screening requirements identified in Section 6121(a)1 are not applicable. Section 6121(a)4 requires that a planter or landscaped area of at least 4 feet wide shall be provided adjacent to all street rights-of-way. Not more than 30 % of the planter or landscaped area may be covered with hard surfaces such as gravel, landscaping rock, concrete, or other impervious materials. The project proposes 4-foot-wide landscaped planters adjacent to California Avenue. The minimum live landscaping requirement is required by Condition 9.
 - Parking. All uses not enumerated in Section 6119 "Parking Spaces Required" which are permitted in the "M" Districts shall provide no less than 1 space for each 2,000 sq. ft. of floor area. Therefore, as the proposed building is 4,900 sq. ft in size, a minimum of 2 onsite parking spaces are required. The project complies with the minimum onsite parking requirement.
- b. Performance Standards: Uses within the Waterfront District are subject to a series of performance standards. The following analyses details the project's compliance with relevant performance standards of the Waterfront District.
- Noise. No use will be permitted which exceeds the following sound levels more than thirty minutes in any hour: No use will be permitted which exceeds the following sound levels more than 30 minutes in any hour: 60 dBA from 7:00 a.m. to 10:00 p.m. or 55

dBA from 10:00 p.m. to 7:00 a.m. Given that the proposal is for the indoor storage of boats, with no assembly, repair, or sale proposed, noise generation is anticipated to meet these provisions. A condition has been added to address temporary noise impacts during construction.

- Lighting. All lighting, exterior and interior, must be designed and located so as to confine direct rays to the premises. External lighting proposed includes four wall-mounted lights. Three are proposed on the front of the building facing California Avenue, and one is proposed above the proposed door on the left (west) side of the building. The light fixtures will be dark sky compliant, which are designed to direct light towards the ground and towards the premises. Internal lighting proposed includes eight ceiling mounted shop lights. The building has minimal windows that will help to contain interior lighting.

4. Use Permit

Section 6503 of the Zoning Regulations requires that, in order to grant the use permit as applied for or conditioned, the findings of the Planning Commission must include that the establishment, maintenance, and/or conducting of the use will not, under the circumstances of the particular case, result in a significant adverse impact to coastal resources, or be detrimental to the public welfare or injurious to property or improvements in said neighborhood. The parcel is currently undeveloped and used as outdoor storage with no trees, no undisturbed areas, minimal to no vegetation, and no streams or other natural drainage systems on the project site. The project is located in a developed urban area adjacent to developed lots where access and utility services are available, is not in an environmentally sensitive area, and coastal views will not be affected. In addition, the building design fits the industrial style that exists in Princeton and will blend well with the overall neighborhood appearance. The proposed project will introduce a new development into the neighborhood that is compatible and complementary to the existing mix of architectural styles and will be an overall improvement to the site and the area. The project, as proposed and conditioned, conforms with all applicable zoning development standards, parking requirements, and design review standards.

5. Conformance with Design Review Standards

The proposed project is in the DR Zoning District and has been reviewed against the applicable design standards contained in Section 6565.17 "Standards for Design in Other Areas" of the Zoning Regulations. The project, as proposed and conditioned, has been found to be compliant with

all applicable design standards contained in Section 6565.17, with particular attention to the standards identified below. No review by the Coastside Design Review Committee was required as the project proposes no residential development.

- Section 6565.17.E. *Trees and other vegetative land cover are removed only where necessary for the construction of structures or paved areas in order to reduce erosion and impacts on natural drainage channels and maintain surface runoff at acceptable levels.*

The parcel is currently used as outdoor storage with no trees, no undisturbed areas, minimal to no vegetation, and no streams or other natural drainage systems on the project site. Stormwater runoff will be contained through an onsite infiltration-based retention feature.

- Section 6565.17.L. *The design of the structure is appropriate to the use of the property and is in harmony with the shape, size, and scale of adjacent building in the community.*

The building design fits the industrial style that exists in Princeton and will blend well with the overall neighborhood appearance. The Princeton area includes a wide range of development that differs with regard to quality, building materials, colors, and architectural styles. The existing undeveloped parcel has minimal to no vegetation and is used for outdoor storage. The proposed project will introduce a new development into the neighborhood that is compatible and complimentary to the existing mix of architectural styles and will be an overall improvement to the site and the area.

B. REVIEW BY THE CALIFORNIA COASTAL COMMISSION, MIDCOAST COMMUNITY COUNCIL, AND PRINCETON CITIZENS ADVISORY COMMITTEE

The project was referred to the California Coastal Commission, Midcoast Community Council, and Princeton Citizens Advisory Committee. No comments were received by the California Coastal Commission or Princeton Citizens Advisory Committee. The Midcoast Community Council provided a response indicating that they have no comments other than requests to limit the permeable surface area and for the containment of any hazardous materials that may be involved with the maintenance or construction of boats. No boat assembly, repair, or outdoor storage is proposed. The project will be for boat storage only. The stormwater runoff from all impervious surface areas would be retained onsite in a new infiltration-based retention feature. Per Condition 15, no hazardous materials shall be stored on-site.

C. ENVIRONMENTAL REVIEW

The project is categorically exempt from the California Environmental Quality Act (CEQA), pursuant to CEQA Guidelines Section 15303, Class 3, relating to the construction and location of limited numbers of new, small facilities or structures. This exemption allows for (c) A store, motel, office, restaurant, or similar structure. In urbanized areas, the exemption also applies to up to four such commercial buildings not exceeding 10,000 sq. ft. in floor area on sites zoned for such use if not involving the use of significant amounts of hazardous substances where all necessary public services and facilities are available, and the surrounding area is not environmentally sensitive. The project proposes a new 4,900 sq. ft. boat storage building and other ancillary onsite improvements. The project is in an urbanized area, proposes less than 10,000 sq. ft. in floor area, the site is zoned for the proposed use, does not involve the storage of hazardous substances, all necessary public services and facilities are available, and the surrounding area is not environmentally sensitive.

D. REVIEWING AGENCIES

Building Inspection Section
California Coastal Commission
Coastside County Water District
Coastside Fire Protection District
Department of Public Works
Granada Community Services District
Midcoast Community Council
Princeton Citizens Advisory Committee

ATTACHMENTS

- A. Recommended Findings and Conditions of Approval
- B. Location Map
- C. Project Plans

County of San Mateo
Planning and Building Department

RECOMMENDED FINDINGS AND CONDITIONS OF APPROVAL

Permit or Project File Number: PLN2024-00035 Hearing Date: December 5, 2024

Prepared By: Luis Topete, Project Planner For Adoption By: Zoning Hearing Officer

RECOMMENDED FINDINGS

Regarding the Environmental Review, Find:

1. That the project is categorically exempt from the California Environmental Quality Act (CEQA), pursuant to CEQA Guidelines Section 15303, Class 3, relating to the construction and location of limited numbers of new, small facilities or structures. The project proposes a new 4,900 sq. ft. boat storage building and other ancillary onsite improvements. The project is in an urbanized area, proposes less than 10,000 sq. ft. in floor area, the site is zoned for the proposed use, does not involve the storage of hazardous substances, all necessary public services and facilities are available, and the surrounding area is not environmentally sensitive.

Regarding the Coastal Development Permit, Find:

2. That the project, as described in the application and accompanying materials required by Zoning Regulations Section 6328.7 and as conditioned in accordance with Section 6328.14, conforms with the plans, policies, requirements, and standards of the San Mateo County Local Coastal Program with regards to the Locating and Planning New Development, Visual Resources, Hazards, and Commercial Fishing/Recreational Boating components. See Section A(2) of the staff report for the supporting analysis demonstrating conformance with the Local Coastal Program.
3. That the project is not subject to public access and public recreation policies of Chapter 3 of the Coastal Act of 1976 (commencing with Section 30200 of the Public Resources Code) since the project is not located between the nearest public road and the sea, or the shoreline of the Pescadero Marsh.
4. That the project conforms to the specific findings required by policies of the San Mateo County Local Coastal Program as discussed in Section A(2) of this staff report. See Section A(2) for the supporting analysis.

Regarding the Use Permit, Find:

5. That the establishment, maintenance and/or conducting of the use will not, under the circumstances of the particular case, result in a significant adverse impact to coastal resources, or be detrimental to the public welfare or injurious to property or improvements in said neighborhood. The parcel is currently undeveloped and used as outdoor storage with no trees, no undisturbed areas, minimal to no vegetation, and no streams or other natural drainage systems on the project site. The project is located in a developed urban area adjacent to developed lots where access and utility services are available, is not in an environmentally sensitive area, and coastal views will not be affected. In addition, the building design fits the industrial style that exists in Princeton and will blend well with the overall neighborhood appearance. The proposed project will introduce a new development into the neighborhood that is compatible and complementary to the existing mix of architectural styles and will be an overall improvement to the site and the area. The project, as proposed and conditioned, conforms with all applicable zoning development standards, parking requirements, and design review standards.

Regarding the Design Review Permit, Find:

6. The project, as proposed and conditioned, conforms to the standards and guidelines for design review applicable to the location of the project and achieves the overall objectives for the establishment and purpose of the design review district. The proposed design and materials are appropriate based upon the suitability of the building for its proposed use, and the design elements of the building are harmonious and proportionate. See Section A(4) of the staff report for the supporting analysis demonstrating conformance with the Design Review Standards.

RECOMMENDED CONDITIONS OF APPROVAL

Current Planning Section

1. This approval applies only to the proposal, documents, and plans described in this report, and submitted to and approved by the Zoning Hearing Officer on December 5, 2024. Modifications beyond those approved by the Zoning Hearing Officer will be subject to review and approval by the Director of Planning and Building and may require review at a public hearing. Minor modifications that are largely consistent with this approval may be approved at the discretion of the Director of Planning and Building.
2. The Coastal Development Permit, Design Review Permit, and Use Permit approvals shall be valid for five years from the date of final approval in which time a building permit shall be issued, and a completed building inspection (to the satisfaction of the Building Inspector) shall have occurred within 180 days of its

issuance. Any extension to these permits shall require submittal of a request for permit extension and payment of applicable extension fees, no less than 60 days prior to expiration. An extension of these approvals will be considered upon written request and payment of the applicable fees 60 days prior to the expiration of the approvals.

3. No site disturbance shall occur until a valid building permit has been issued.
4. All exterior lighting shall be designed and located so as to confine direct rays to the subject property and prevent glare in the surrounding area. Exterior lighting shall be installed per the approved plans. Please submit design manufacturer's "cut sheets" with the building permit application prior to the issuance of a building permit. Prior to Planning final of the building permit for this project, the applicant shall submit photos verifying compliance with this condition.
5. Any new utilities shall be located underground from the nearest existing pole. No new poles are permitted to be installed.
6. The proposed exterior building color is approved. Any changes to the exterior color of the building shall require review and approval by the Planning and Building Department prior to implementing.
7. Colors and material samples shall be submitted to the Planning Department at the time of application for a building permit. Approved colors and materials shall be confirmed prior to a final inspection for the building permit.
8. Any signage shall require separate approval by the Planning and Building Department prior to installation.
9. A planter or landscaped area of at least 4 feet wide shall be provided adjacent to all street rights-of-way. Not more than 30 % of the planter or landscaped area may be covered with hard surfaces such as gravel, landscaping rock, concrete, or other impervious materials.
10. Landscaping plans, including size, species, and location, for all proposed landscaping shall be submitted as part of the building permit for review and approval. Prior to building inspection final and certificate of occupancy, the Planning Department shall verify that the approved landscaping has been installed.
11. All approved landscaping shall be maintained in a healthy condition for the life of the use. Any dead or dying landscape shall be removed and replaced with the same or similar species.
12. The approved use shall maintain compliance with the noise, odor, lighting, and vibration standards of the Waterfront District.

13. The applicant shall adhere to Best Management Practices for erosion and sediment control throughout the duration of project construction. Erosion control measure deficiencies, as they occur, shall be immediately corrected. The goal is to prevent sediment and other pollutants from leaving the project site and to protect all exposed earth surfaces from erosive forces. Said plan shall adhere to the San Mateo Countywide Stormwater Pollution Prevention Program “General Construction and Site Supervision Guidelines,” including:
- a. Stabilizing any denuded areas and maintaining erosion control measures continuously between October 1 and April 30. Stabilizing shall include both proactive measures, such as the placement of hay bales or coir netting, and passive measures, such as revegetating disturbed areas with plants propagated from seed collected in the immediate area.
 - b. Storing, handling, and disposing of construction materials and wastes properly, so as to prevent their contact with stormwater.
 - c. Controlling and preventing the discharge of all potential pollutants, including pavement cutting wastes, paints, concrete, petroleum products, chemicals, wash water or sediments, and non-stormwater discharges to storm drains and watercourses.
 - d. Using sediment controls or filtration to remove sediment when dewatering the site and obtaining all necessary permits.
 - e. Avoiding cleaning, fueling, or maintaining vehicles on-site, except in a designated area where wash water is contained and treated.
 - f. Delineating with field markers clearing limits, easements, setbacks, sensitive or critical areas, buffer zones, trees, and drainage courses.
 - g. Protecting adjacent properties, buildings, and undisturbed areas from construction impacts using vegetative buffer strips, sediment barriers or filters, dikes, mulching, or other measures as appropriate.
 - h. Performing earth-moving or ground disturbing activities only during dry weather.
 - i. Limiting and timing application of pesticides and fertilizers to prevent polluted runoff.
 - j. Limiting construction access routes and stabilizing designated access points.
 - k. Avoiding tracking dirt or other materials off-site; cleaning off-site paved areas and sidewalks using dry sweeping methods.

- I. The contractor shall train and provide instructions to all employees and subcontractors regarding the construction best management practices.
14. To reduce the impact of construction activities on neighboring properties and/or the public roadways, comply with the following:
 - a. All debris shall be contained on-site; a dumpster or trash bin shall be provided on-site during construction to prevent debris from blowing onto adjacent properties. The applicant shall monitor the site to ensure that trash is picked up and appropriately disposed of daily.
 - b. The applicant shall remove all construction equipment from the site upon completion of the use and/or need of each piece of equipment which shall include but not be limited to tractors, back hoes, cement mixers, etc.
 - c. The applicant shall ensure that no construction-related vehicles will impede through traffic along any public right-of-way. All construction vehicles shall be parked on-site outside of any public right-of-way. There shall be no storage of construction vehicles, equipment, or materials in any public right-of-way or shared driveway.
15. The applicant shall ensure that during construction, noise, light, dust, odor, and other interference with persons and property off the development site is minimized. Furthermore, no hazardous materials shall be stored on-site.
16. Noise sources associated with demolition, construction, repair, remodeling, or grading of any real property shall be limited to the hours from 7:00 a.m. to 6:00 p.m. weekdays and 9:00 a.m. to 5:00 p.m. Saturdays. Said activities are prohibited on Sundays, Thanksgiving, and Christmas (San Mateo County Ordinance Code Section 4.88.360).

Building Inspection Section

17. A building permit shall be applied for and issued prior to the start of any construction.
18. The project shall comply with all requirements of the California Building Code, including compliance with all accessibility requirements of the Americans with Disabilities Act.

Drainage

19. Based on the information provided, this project is classified as a “C.3 Regulated” (Standard Review). This classification of project is required to have a comprehensive precise stormwater treatment and drainage plan and drainage report prepared by a California Registered Professional Civil Engineer (PE). Ensure to reference the SMCWPPP - San Mateo County Wide C.3 Regulated Projects Guide for requirements and Site Design Measures.

Geotechnical

20. Provide a Geotechnical Study for the proposed project at time of Building Application submittal. Although this project is not located within a mapped fault, landslide, or liquefaction zone, the scope and size of the project will trigger the general requirement for a soil’s evaluation and verification of soils type, bearing capacity, and design criteria.
21. Ensure that the geotechnical report information and design criteria is based on the current 2022 addition of the California Building Code Series to include all relevant standards.

Department of Public Works

22. Driveway entrance shall be constructed to County standards.
23. Boats and vehicles must be maneuvered and parked entirely on-site.
24. Sight/visibility triangles need to be shown on plans. Project will be required to remove/modify all objects including but not limited to fences etc. that are not compliant with height and clearance requirements.
25. Driveway egress shall be STOP-controlled with proper signage and markings to control conflict points with pedestrians/bicyclists/vehicles as they enter the public roadway and improve safety.

Coastside Fire Protection District

26. Address Numbers: Building identification shall be conspicuously posted and visible from the street. (TEMPORARY ADDRESS NUMBERS SHALL BE POSTED PRIOR TO COMBUSTIBLES BEING PLACED ON SITE). The letters/numerals for permanent address numbers shall be of 6-inch height with a minimum 1/2-inch stroke and of a color, which is contrasting with the background. Such letter/numerals shall be illuminated and facing the direction of access.

Distance from Road	Address No. Size
0-50 feet	6-inch
50-100 feet	8-inch
100-150 feet	10-inch
150 + feet	12-inch

with a corresponding increase in stroke width.

27. Address numbers and directional signs may be required at the entrance to the driveway/access road, road forks, and intersections. When located on the street the numbers shall be visible from each direction of travel. This remote signage shall consist of a 6-inch by 18-inch green reflective metal sign with 3-inch reflective Numbers/ Letters similar to Hy-Ko 911 or equivalent.
28. Automatic Fire Sprinkler System: The proposed project must be equipped with an approved NFPA 13 system per Coastside Fire Protection District. You will not be issued a building permit until fire sprinkler plans are received, reviewed, and approved by the fire district. If you have not already done so, please submit the required plans to the San Mateo County Building Department. Please be advised that the sprinkler system design shall be based on an at least Ordinary Hazard or higher classification based on stored commodity. Please provide information as to commodity including number of expected boats and if they will be stored vertically on racks. Please submit plans showing the location of all required fire sprinkler hardware to the San Mateo County Building Department.
29. Unobstructed fire sprinkler coverage: shall extend to all areas in the occupancy. Any areas creating compartmentalization due to new walls shall have additional sprinkler heads installed to provide unobstructed coverage. Any heat producing appliances that are hooked up to an electrical power source, natural or propane gas, and are operational shall not have sprinkler heads located within their respective heat zones.
30. Clearly identify fire service line on plans and verify that line meets minimum size for fire sprinkler hydraulic calculations.
31. Fire Sprinkler Hardware: Along with the automatic fire sprinkler system, this project is required to install all related fire sprinkler hardware (Double Check, Fire Department Connection and Exterior Bell). You will not be issued a building permit until plans have been submitted, reviewed and approved by the fire district. Please submit plans showing the location of all required fire sprinkler hardware to the San Mateo County Building Department.

32. Show location of fire hydrant on a site plan. A fire hydrant is required within 500 feet of the building and flow a minimum of 1000 gpm at 20 psi. This information is to be verified by the water purveyor in a letter initiated by the applicant and sent to San Mateo County Fire/CAL Fire or Coastside Fire District. If there is not a hydrant within 500 feet with the required flow, one will have to be installed at the applicant's expense.
33. Vegetation Management (LRA): A fuel break of defensible space is required around the perimeter of all structures to a distance of not less than 30 feet and may be required to a distance of 100 feet or to the property line. This is neither a requirement nor an authorization for the removal of living trees. Trees located within the defensible space shall be pruned to remove dead and dying portions, and limbed up 6 feet above the ground. New trees planted in the defensible space shall be located no closer than 10 feet to adjacent trees when fully grown or at maturity. Remove that portion of any existing trees, which extends within 10 feet of the outlet of a chimney or stovepipe or is within 5 feet of any structure. Maintain any tree adjacent to or overhanging a building free of dead or dying wood.
34. Exiting: Exiting shall comply with Table 1006.2.1. Maximum path of travel to the exit is 100 feet. Proposed location of the exit exceeds that distance. Exit door shall be moved to a new location.
35. Emergency Building Access: The proposed project will require the installation of "Knox Boxes." These emergency key boxes are required when access to or within a structure or an area is unduly difficult because of secured openings or where immediate access is necessary for life saving or fire-fighting purposes. The Chief will determine the location for the key box and provide an authorized order form. All security gate systems controlling vehicular access shall be equipped with a "Knox"; key operated emergency entry device. For application and instructions please email cfpdfiremarshal@fire.ca.gov if you need further assistance.
36. Fire Alarm System: This project is required to have installed an approved NFPA 72 Fire Alarm System. The system is to monitor any flow through the required automatic fire sprinkler system, and any fire sprinkler valve tamper. Specify if this will be a central or remote station. Ten or more heads will require a central monitoring station per Coastside Fire Protection District Ordinance.
37. Fire Extinguishers: There must be at least one 2A10BC fire extinguisher for each 1,500 sq. ft., travel distance not to exceed 75 feet with at least one extinguisher per floor per Title 19, California Code of Regulations. Show location of extinguishers on plans.
38. Provide Penetration protection in all membranes through fire rated assemblies (i.e., dampers, fire caulking).

39. Fire Alarm systems that meets NFPA 72 will be required.
40. A Certificate of Completion for Fire Sprinkler System requirement at final.
41. A Certificate of Completion for Fire Alarm required at final.
42. A Certificate of Completion for Underground required at final.
43. A current 5-year Certification for the Fire Sprinklers and Fire Alarm required at final.
44. Community Facilities District: The Fire District requires the formation of a Mello-Roos Community Facilities District (CFD) for all new construction of three or more residential units. Please contact the Fire District administration office for more details. Please be advised that the formation of a CFD takes approximately three months. The formation of a CFD is a condition of development and required to be completed prior to Fire District final approval and sign-off on the project.

Granada Community Services District

45. All new construction projects require a Sewer Connection Permit from the District. If the subject parcel conforms in size with the County's zoning requirements, the applicant may submit a sewer permit application after receiving County Planning approval. The District can be reached by calling their office at 650/ 726-7093 or by e-mail at gcsdadmin@granada.ca.gov to obtain instructions and an application form.
46. The applicant will be required to submit the construction plans with their sewer permit application form and other items. The construction plans must show all sewer lines necessary for the development including sewer pipes (lateral and sewer mainline), appurtenances, manholes, cleanouts and sewer backflow devices, which must conform to District standards. Upon District receipt of the Building Department Pick-up Notice and payment of the permit fees, the sewer connection permit will be issued over the counter.

Coastside County Water District

47. The project is required to comply with Coastside County Water District's regulations on water service and metering. The Coastside County Water District performs inspections to verify compliance with all District regulations during construction and a final inspection when construction is complete.
48. Show driveway and driveway aprons on utility plan to show clearance from domestic and fire meters with building permit submittals. Note that parking is not allowed on top of meter boxes.

49. Show any fencing that will be installed to show that meters and backflow devices remain accessible by District staff with building permit submittals.
50. Provide landscape and irrigation plans with building permit submittals. Irrigated landscaping 5,000 sq. ft. and over requires a separate dedicated irrigation meter (DIM).
51. Fire sprinklers are served from an independent and dedicated water service connection with a separate fire meter. Coastside County Water District does not allow passive purge systems to be installed on fire protection services. Fire protection services are authorized for the sole purpose of fire protection, and there shall be no cross connections.
52. A full set of the most recent plans and drawings for the project, (fire sprinkler, architectural, plumbing, mechanical, green building, structural, civil, utility, and landscape/irrigation) must be submitted to the District for review and approval. Existing and new utilities must be clearly marked on the drawings.
53. Before issuance of a building permit, the Coastside County Water District will still need to evaluate a complete set of building plans to determine if the water service capacity available is adequate for this development and it complies with all Coastside County Water District regulations.



COUNTY OF SAN MATEO - PLANNING AND BUILDING DEPARTMENT

ATTACHMENT B



WGS_1984_Web_Mercator_Auxiliary_Sphere
© Latitude Geographics Group Ltd.

1:1,643

This map is a user generated static output from an Internet mapping site and is for reference only. Data layers that appear on this map may or may not be accurate, current, or otherwise reliable.

THIS MAP IS NOT TO BE USED FOR NAVIGATION



COUNTY OF SAN MATEO - PLANNING AND BUILDING DEPARTMENT

ATTACHMENT C



SITE DATA:
 APN: 047-095-090
 ZONING: MDR/CD
 OCCUPANCY GROUP: 2
 TYPE OF CONSTRUCTION: 2

PRE:
 PLN:
 BLD:

APPLICABLE CODES:
 HALF MOON BAY CITY ZONING & BUILDING ORDINANCES

2022 CALIFORNIA RESIDENTIAL CODE
 2022 CALIFORNIA BUILDING CODE
 2022 CALIFORNIA MECHANICAL CODE
 2022 CALIFORNIA PLUMBING CODE
 2022 CALIFORNIA ELECTRICAL CODE
 2022 CALIFORNIA ENERGY CODE
 2022 CALIFORNIA FIRE CODE
 2022 CALIFORNIA GREEN BUILDING STANDARDS CODE

OWNER:
 ART AND THELMA FRENCH
 20 FARAWAY MONTARA, CA 94037
 THELMA.FRENCH@GMAIL.COM

CONTRACTOR:
 BRYAN FALVY
 FALCO CONSTRUCTION
 P.O. BOX 2263
 EL GRANADA, CA 94018
 falcohmb1@gmail.com

CIVIL:
 SIGMA PRIME GEOSCIENCES
 CHARLES KISSICK
 322 PRINCETON AVE
 HALF MOON BAY, CA 94019
 650.728.3590
 sigmaprm@gmail.com

SURVEYING:
 BGT SURVEYING
 BRIAN TAYLOR
 871 WOODSIDE WAY
 SAN MATEO, CA 94401
 650.212.1030
 bgtinfo@bgtsurveying.com

ARCHITECT:
 EDWARD C LOVE, ARCHITECT
 720 MILL ST
 HALF MOON BAY, CA 94019
 650.728.7615
 edwardclovearch@gmail.com

SCOPE OF WORK:
 BUILD A 4900 SQUARE FOOT BOAT STORAGE
 BUILDING ON AN 10498 SQUARE FOOT LOT

	EXISTING		PROPOSED		TOTAL		ALLOWED	
	AREA (SQFT)	%	AREA (SQFT)	%	AREA (SQFT)	%	AREA (SQFT)	%
LOT AREA	10498							
LOT COVERAGE	0	0.0	4900	46.7	4900	46.7	10498	100.0
FLOOR AREA								
Total	0	0.0	Total	4900	46.7	Total	4900	46.7
			Total			Total	10498	100.0

Sheet List

Sheet Number	Sheet Name	Rev
A001	Cover Sheet	
SU-1	Survey	
A100	Site Plan Existing	
A101	Site Plan Proposed	
C-1	Grading & Drainage Plan	
C-2	Erosion Control	
A102	Floor Plan	
A103	Roof Plan	
A201	Elevation North & South	
A202	Elevations East & West	
A203	Section	
A204	Spec Sheets	

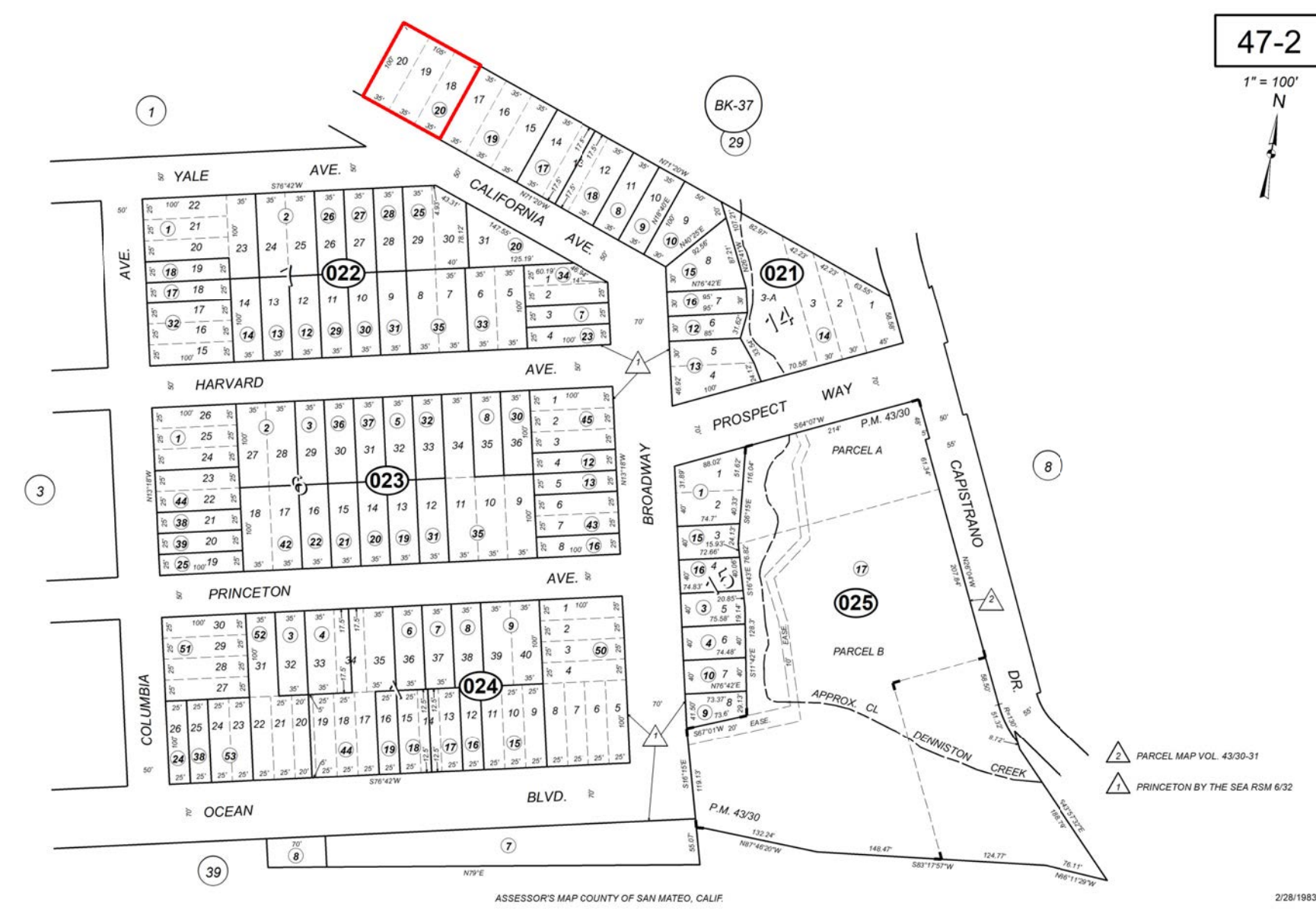

REVISIONS



Edward C. Love
 Architect
 720 MILL STREET
 HALF MOON BAY, CA 94019
 (650) 728-7615
 edwardclovearch@gmail.com

French Storage
 Art & Thelma French
 166 California Ave HMB, CA

Cover Sheet

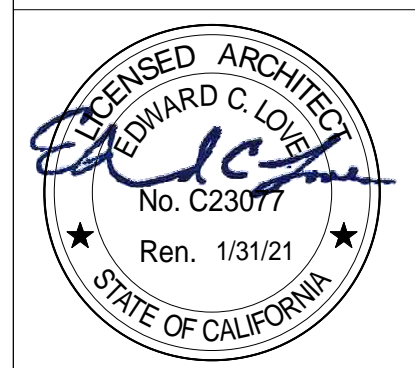

DATE: 9/3/2024
 SCALE:
 DRAWN: Boon
 JOB: French Storage
 SHEET:
A001
 OF SHEETS

S:\Client Projects 2024\French Storage\Revit\French Storage.rvt

BASIS OF BEARINGS

THE BEARING, SOUTH 13°17'53" EAST, OF THE CENTERLINE OF BROADWAY (OUTSIDE MAPPING LIMITS), AS SHOWN ON THAT CERTAIN RECORD OF SURVEY WHICH WAS FILED FOR RECORD IN VOLUME 25 OF LLS MAPS PAGES 87-89 ON JANUARY 26, 2004, SAN MATEO COUNTY RECORDS, WAS USED AS THE BASIS OF BEARINGS FOR THIS SURVEY.

BENCHMARK

ELEVATIONS ARE BASED UPON NAVD 88 DATUM. BENCHMARK USED WAS "TIDAL 5" (PID HT0455) WITH A PUBLISHED ELEVATION OF 14.22 FEET. SITE BENCHMARK IS THE SANITARY SEWER MANHOLE LID WITH AN ELEVATION OF 22.10 FEET.

NOTES:

BGT RELIED UPON LAWYERS TITLE INSURANCE COMPANY PRELIMINARY TITLE REPORT, NO. 0052300702, AS TITLE REFERENCE. NO EASEMENTS WERE REFERENCED WITHIN SAID REPORT.

UTILITIES SHOWN HEREON TAKEN FROM VISUAL SURFACE EVIDENCE AND SHOULD BE CONSIDERED AS APPROXIMATE ONLY. ACTUAL LOCATIONS OF UTILITIES MAY VARY. TRUE LOCATION OF UTILITIES CAN ONLY BE OBTAINED BY EXPOSING THE UTILITY.

THE LOCATION OF THE SEWER CLEANOUT WAS NOT FOUND BY THE FIELD CREW. THEREFORE, THE CLEANOUT(S), AND THE PROBABLE LOCATION OF THE SEWER LATERAL COULD NOT BE VERIFIED. VERIFICATION TO BE DONE BY OTHERS.

TREE LOCATIONS SHOWN HEREON ARE SHOWN SYMBOLICALLY WITH SYMBOL SIZES BASED UPON TRUNK DIAMETER AT CHEST HEIGHT, AT THE LOCATION WHERE THE TREE ENTERS THE GROUND SURFACE. LOCATIONS AND SIZES OF TREE TRUNKS CAN ONLY BE CONSIDERED APPROXIMATE UNLESS OTHERWISE STATED ON THE MAP. TREES OF TRUNK DIAMETER SIZES OF 6 INCHES OR GREATER WERE LOCATED BY THE FIELD CREW.

SURVEY PERFORMED BY: BGT LAND SURVEYING
www.bgtsurveying.com

DATE OF FIELD SURVEY: SEPTEMBER 13, 2023
JOB NUMBER: 23-122

MAP OF PRINCETON BY THE SEA
BOOK 6 MAPS 32
BLOCK 14

LEGEND

AC	ASPHALT CONCRETE	MH	MH (TYPE UNKNOWN)
BW	BACK OF WALK	MON-MON	MONUMENT TO MONUMENT DISTANCE
CB	CATCH BASIN	PBV	PACBELL/SBC VAULT
C/L	CENTERLINE	PGE	P&GE VAULT
CMP	CORRUGATED METAL PIPE	PIV	POST INDICATOR VALVE
CI	CAST IRON PIPE	SDI	STORM DRAIN INLET
CO	CLEAN OUT BOX	SDMH	STORM DRAIN MANHOLE
CP	SURVEY CONTROL POINT	SL	STREET LIGHT
CPP	CORRUGATED PLASTIC PIPE	SLB	STREET LIGHT BOX
CTV	CABLE TELEVISION LINE	SLV	STREET LIGHT VAULT
DI	DROP INLET	SSMH	SANITARY SEWER MANHOLE
EM	ELECTRIC METER	SSV	SANITARY SEWER VAULT
EV	ELECTRIC VAULT	TBC	TOP BACK OF CURB
FF	FINISHED FLOOR	TBM	TEMPORARY BENCHMARK
FL	FLOWLINE	TS	TRAFFIC SIGNAL
FH	FIRE HYDRANT	TSB	TRAFFIC SIGNAL BOX
GM	GAS METER	UNK	UNKNOWN TYPE
GRD	GROUND	VCP	VITRIFIED CLAY PIPE
GUY	GUY ANCHOR	WBF	WATER BACK FLOW VALVE
GV	GAS VALVE	WM	WATER METER BOX
HCR	HANDICAP RAMP	WV	WATER VALVE
HVE	HIGH-VOLT ELECTRIC	-CTV-	CABLE TELEVISION LINE
INV.	INVERT	-E-	ELECTRICAL LINE
IP	IRON PIPE	-G-	GAS LINE
JP	JOINT POLE	-OH-	OVERHEAD LINE
KV	KILOVOLT	-SD-	STORM DRAIN LINE
LAT.	LATERAL	-SS-	SANITARY SEWER LINE
LG	LIP OF GUTTER	-T-	TELEPHONE LINE
		-W-	WATER LINE

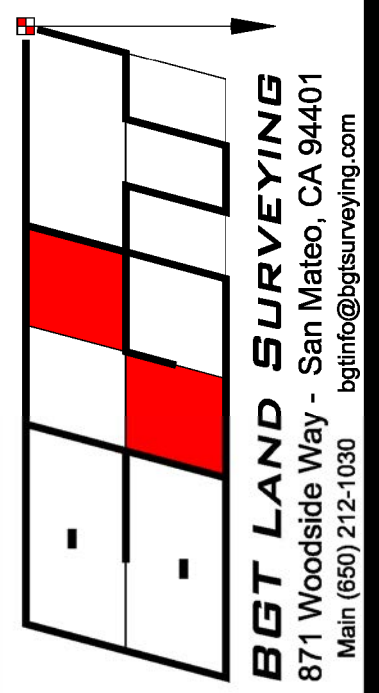
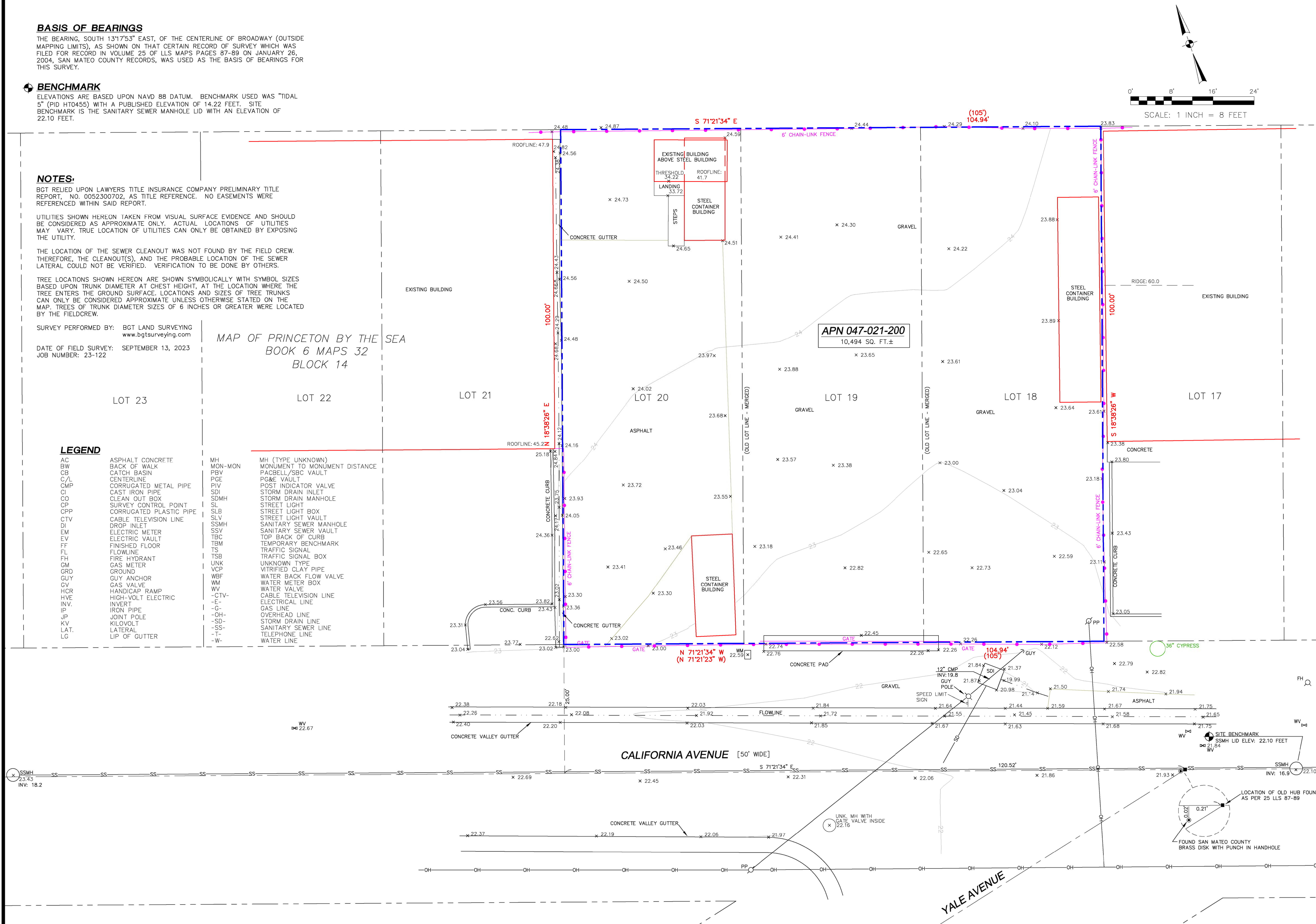

BOUNDARY AND TOPOGRAPHIC SURVEY
 LOTS 18-20, BLOCK 14, "MAP OF PRINCETON BY THE SEA" (BOOK 6 MAPS 32)
166 CALIFORNIA AVENUE
 PRINCETON (UNINCORPORATED), SAN MATEO COUNTY, CALIFORNIA

Assessor Parcel Number:
047-021-200

Prepared For:
ARTHUR T. FRENCH
PO BOX 371454
MONTARA, CA 94037

Date: SEPT. 2023
 Scale: 1" = 8'
 Contour Interval: 1'
 Drawn by: BGT
 Revisions:

SU-1
 Job No. 23-122

S:\Client Projects 2024\French Storage\Revit\French Storage.rvt

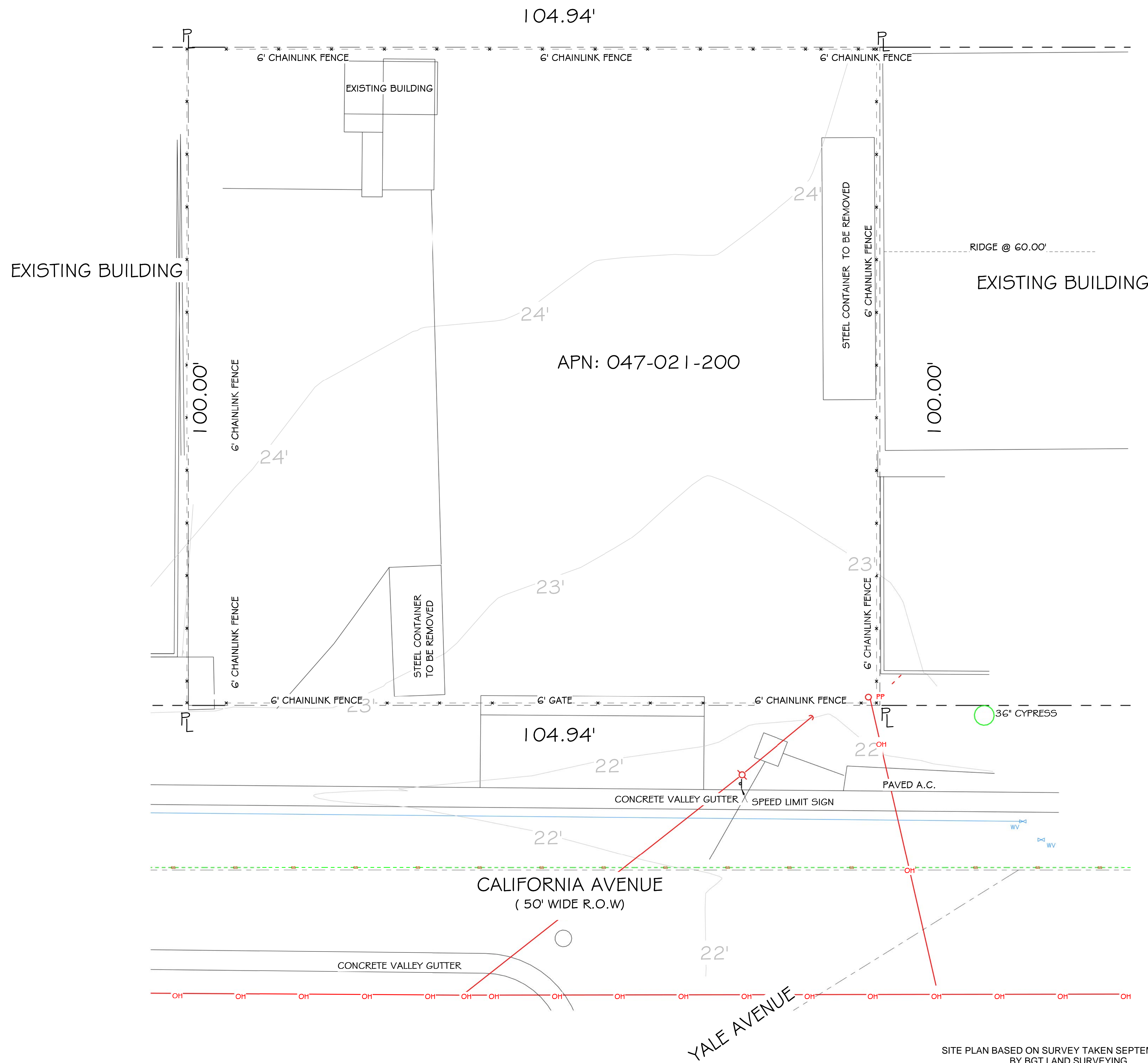

REVISIONS



Edward C. Love
Architect
720 MILL STREET
HALF MOON BAY, CA 94019
(650) 728-7615
edwardclovearch@gmail.com

French Storage
Art & Thelma French
166 California Ave HMB, CA

Site Plan Existing



DATE: 9/3/2024
SCALE: 1/8" = 1'-0"
DRAWN: Boon
JOB: French Storage

SHEET:
A100
OF SHEETS

SITE PLAN BASED ON SURVEY TAKEN SEPTEMBER 2023
BY BGT LAND SURVEYING

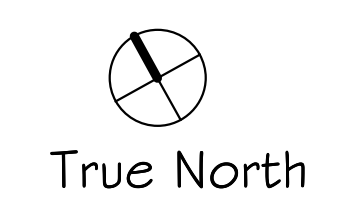
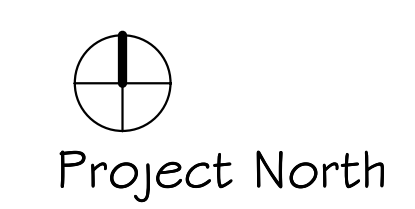

S:\Client Projects 2024\French Storage\Revit\French Storage.rvt

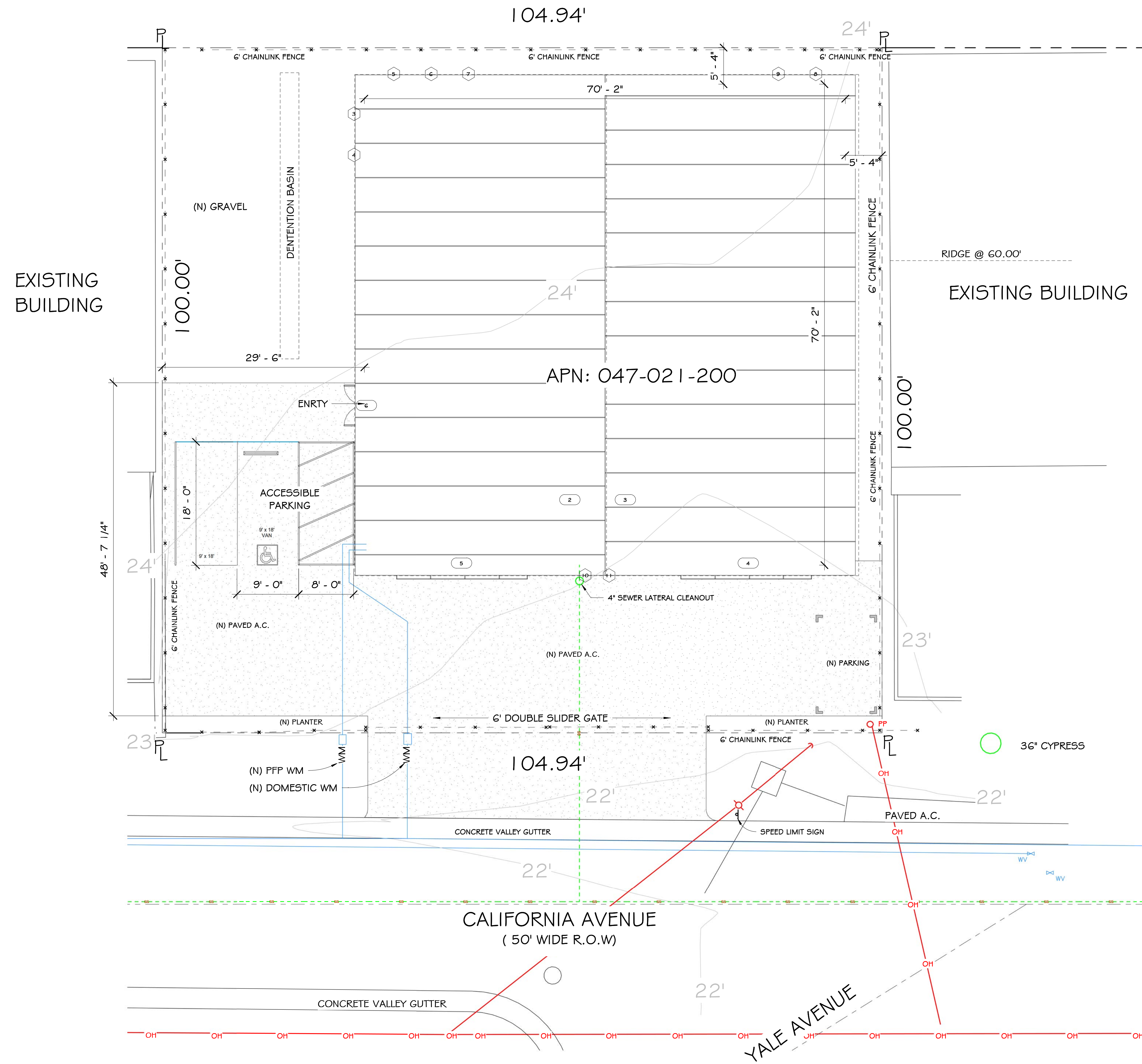

SITE PLAN BASED ON SURVEY TAKEN SEPTEMBER 2023 BY BGT LAND SURVEYING

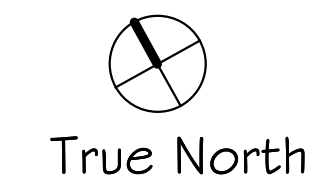

REVISIONS



EDWARD C. LOVE, ARCHITECT

Edward C. Love
Architect
720 MILL STREET
HALF MOON BAY, CA 94019
(650) 728-7615
edwardclovearch@gmail.com

French Storage
Art & Thelma French
166 California Ave HMB, CA

Site Plan Proposed



DATE: 9/3/2024

SCALE: 1/8" = 1'-0"

DRAWN: Boon

JOB: French Storage

SHEET:

A101

OF SHEETS

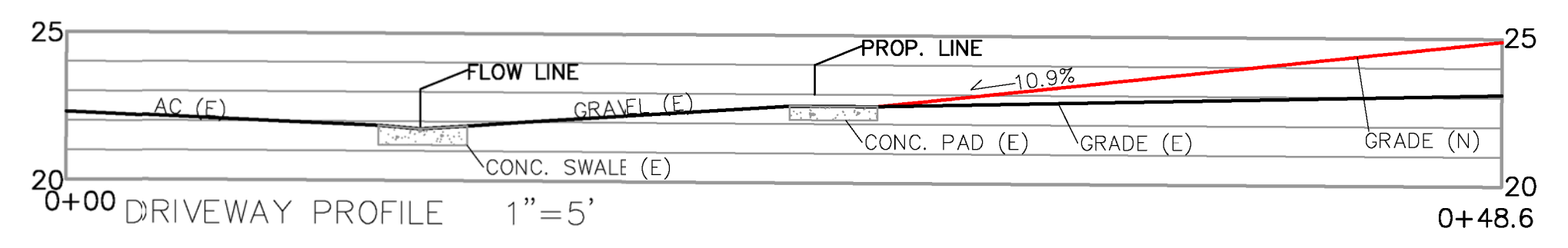
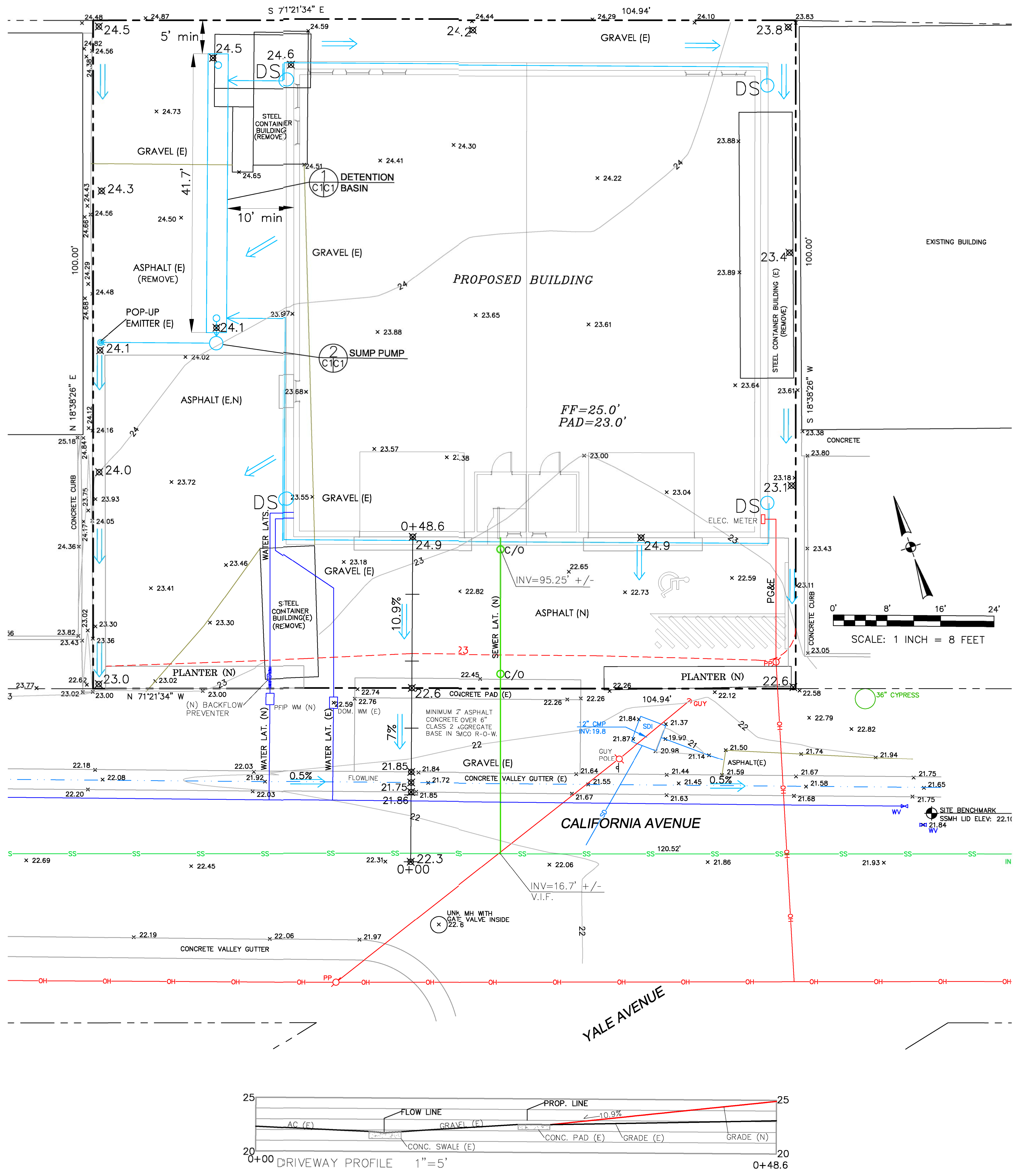

LEGEND

- EXISTING CONTOUR
- - - PROPOSED CONTOUR
- x 23.88 EXISTING SPOT ELEVATION
- x 23.8 PROPOSED SPOT ELEVATION
- SURFACE DRAINAGE DIRECTION
- DS DOWNSPOUT
- 4" MV SOLID DRAIN PIPE

GENERAL NOTES

1. PLANS PREPARED AT THE REQUEST OF: THELMA FRENCH, OWNER
2. TOPOGRAPHY BY BGT LAND SURVEYING, SURVEYED 9-13-23.
3. THIS IS NOT A BOUNDARY SURVEY.
4. ELEVATION DATUM: NAVD88.
5. THE GEOTECHNICAL REPORT: **GEOTECHNICAL STUDY:** GEOTECHNICAL REPORT FOR PROPOSED COMMERCIAL BUILDING, 166 CALIFORNIA AVENUE, BY SIGMA PRIME GEOSCIENCES, DATED 10-2-23, PROJECT NO. 23-194 SHALL BE RETAINED ON THE CONSTRUCTION SITE. THE GEOTECHNICAL ENGINEER OF RECORD IS SIGMA PRIME GEOSCIENCES, INC., WITH THE CONTACT NUMBER (650) 728-3590 (SIGMAPRM@GMAIL.COM). THE CONTRACTOR MUST NOTIFY THE GEOTECHNICAL ENGINEER OF RECORD AT LEAST 48 HOURS BEFORE CONSTRUCTION OF GEOTECHNICAL RELATED WORK. THE GEOTECHNICAL PART OF CONSTRUCTION WORK, INCLUDING BUT NOT LIMITED TO, ALL THE EARTHWORK AND FOUNDATION CONSTRUCTIONS, MUST BE APPROVED BY THE GEOTECHNICAL ENGINEER OF RECORD.
6. STORMWATER MANAGEMENT CONSTRUCTION INSPECTIONS SHALL BE SCHEDULED FOR APPLICABLE DRAINAGE INSPECTIONS, WHICH INCLUDE SITE CLEARANCE AND EROSION CONTROL MEASURES INSTALLATION AS WELL AS INSPECTION OF MAJOR DRAINAGE CONTAINMENT, TREATMENT, AND CONVEYANCE DEVICES BEFORE BEING BURIED (INCLUDING REQUIRED MATERIAL LABELS, E.G. PIPES, SUB-GRADE MATERIALS, ETC.). PLEASE FOLLOW THE INSPECTION CARD INSTRUCTIONS AND CALL SIGMA PRIME AT 650-728-3590 TO SCHEDULE DRAINAGE INSPECTIONS ACCORDINGLY. THERE SHALL BE THREE INSPECTIONS: ONE FOR EROSION CONTROL INSTALLATION, ONE BEFORE DRAINAGE FACILITIES ARE BURIED, AND ONE FOR FINAL WALK AROUND.
7. APPLICANT MUST OBTAIN ENCROACHMENT PERMIT FOR ALL WORK IN THE COUNTY RIGHT-OF-WAY. FAILURE TO HAVE APPROVED INSPECTIONS BY THE ROAD INSPECTOR MAY DELAY BUILDING PERMIT OCCUPANCY.
8. NO NET INCREASE IN STORMWATER RUN-OFF MAY DRAIN ONTO ADJACENT PROPERTIES.
9. THE OWNER SHALL ADEQUATELY MAINTAIN THE PROPERTY'S STORMWATER MANAGEMENT FACILITIES.

GRADING NOTES

CUT VOLUME : 200 CY (FOR FOUNDATION)
 FILL VOLUME: 0 CY

VOLUMES ABOVE ARE APPROXIMATE.

THE SUBGRADE BELOW ALL PAVED AREAS SHALL BE BASEROCK COMPACTED TO 95%.

ALL GRADING SHALL CONFORM TO LOCAL CODES AND ORDINANCES.

DRAINAGE NOTES

1. DRAINAGE INTENT: IT IS THE INTENT OF THE DRAINAGE SYSTEM TO CONVEY ROOF RUNOFF TO A SAFE LOCATION, AND TO MINIMIZE EXCESSIVE MOISTURE AROUND FOUNDATIONS. DIRECT SLOPES SUCH THAT STORMWATER WILL NOT BE DIVERTED ONTO ADJACENT PROPERTIES.
2. ALL DOWNSPOUT DRAIN LINES SHALL LEAD TO DETENTION BASIN, AS SHOWN.
3. ALL ROOF DRAINAGE PIPES SHALL BE 4" DIAMETER MINIMUM SOLID PIPE, SLOPED AT 1% MINIMUM.
4. IT IS THE PROPERTY OWNER'S RESPONSIBILITY TO CHECK ON ALL STORMWATER FACILITIES SUCH AS ROOF GUTTERS, DOWNSPOUT LINES, SUMP PUMP, AND THE DETENTION BASIN TO BE SURE THAT THEY ARE CLEAR OF EXCESSIVE DEBRIS AND OPERATING EFFICIENTLY. THE FACILITIES SHALL BE CHECKED EVERY FALL AND PERIODICALLY DURING THE RAINY SEASON.

SECTION AND DETAIL CONVENTION

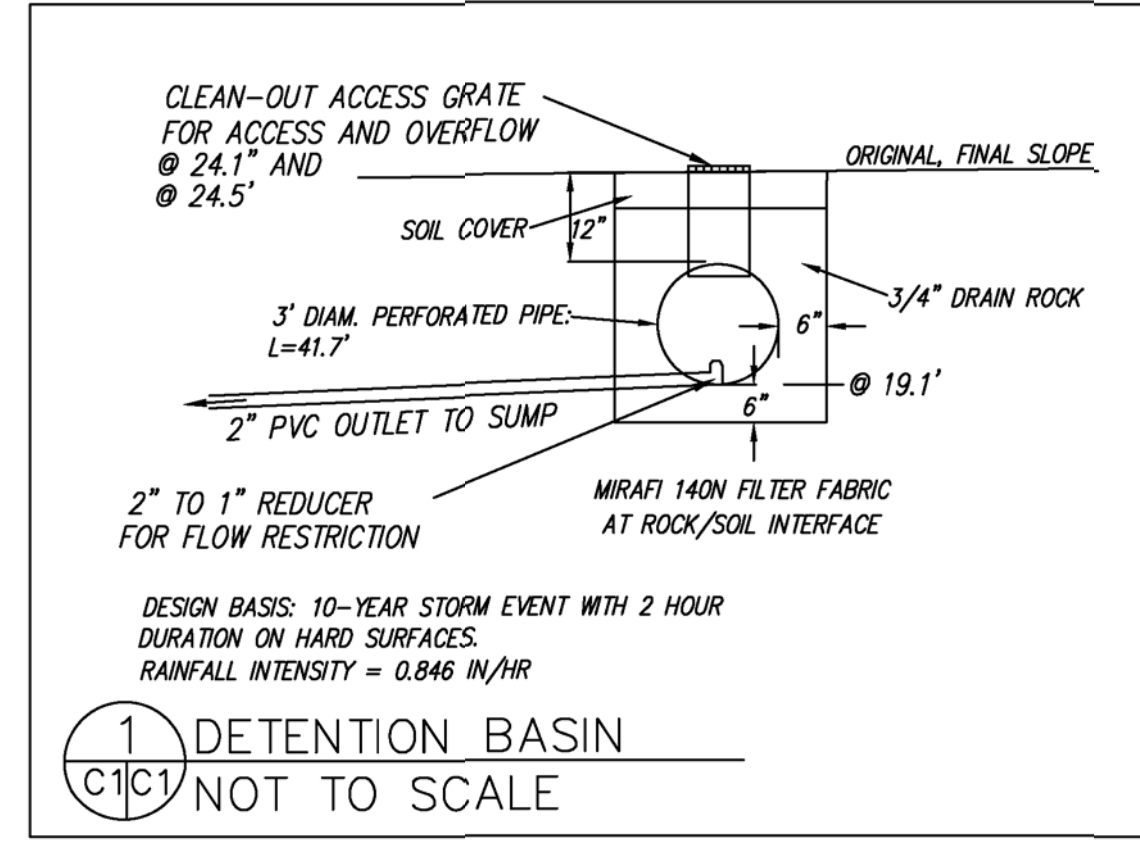
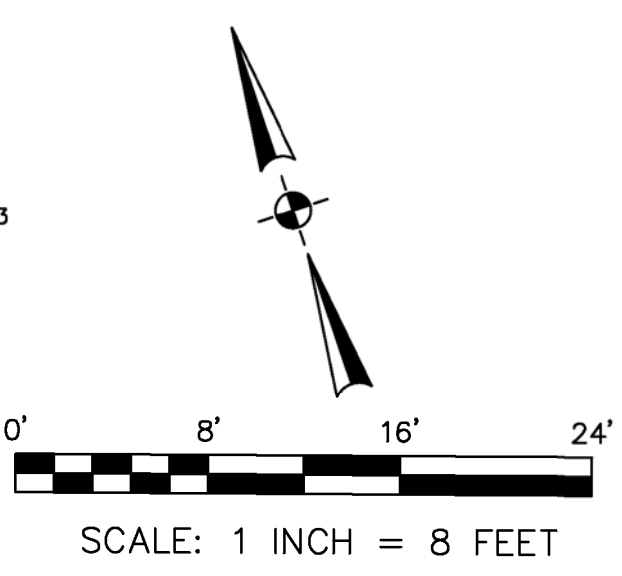
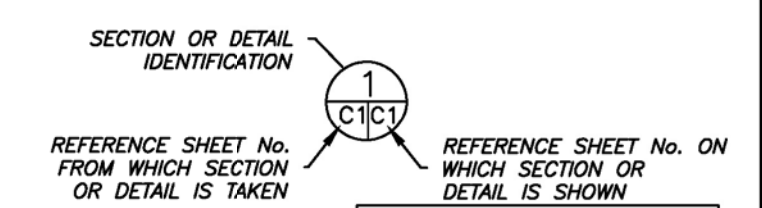

1 DETENTION BASIN
 C1/C1 NOT TO SCALE

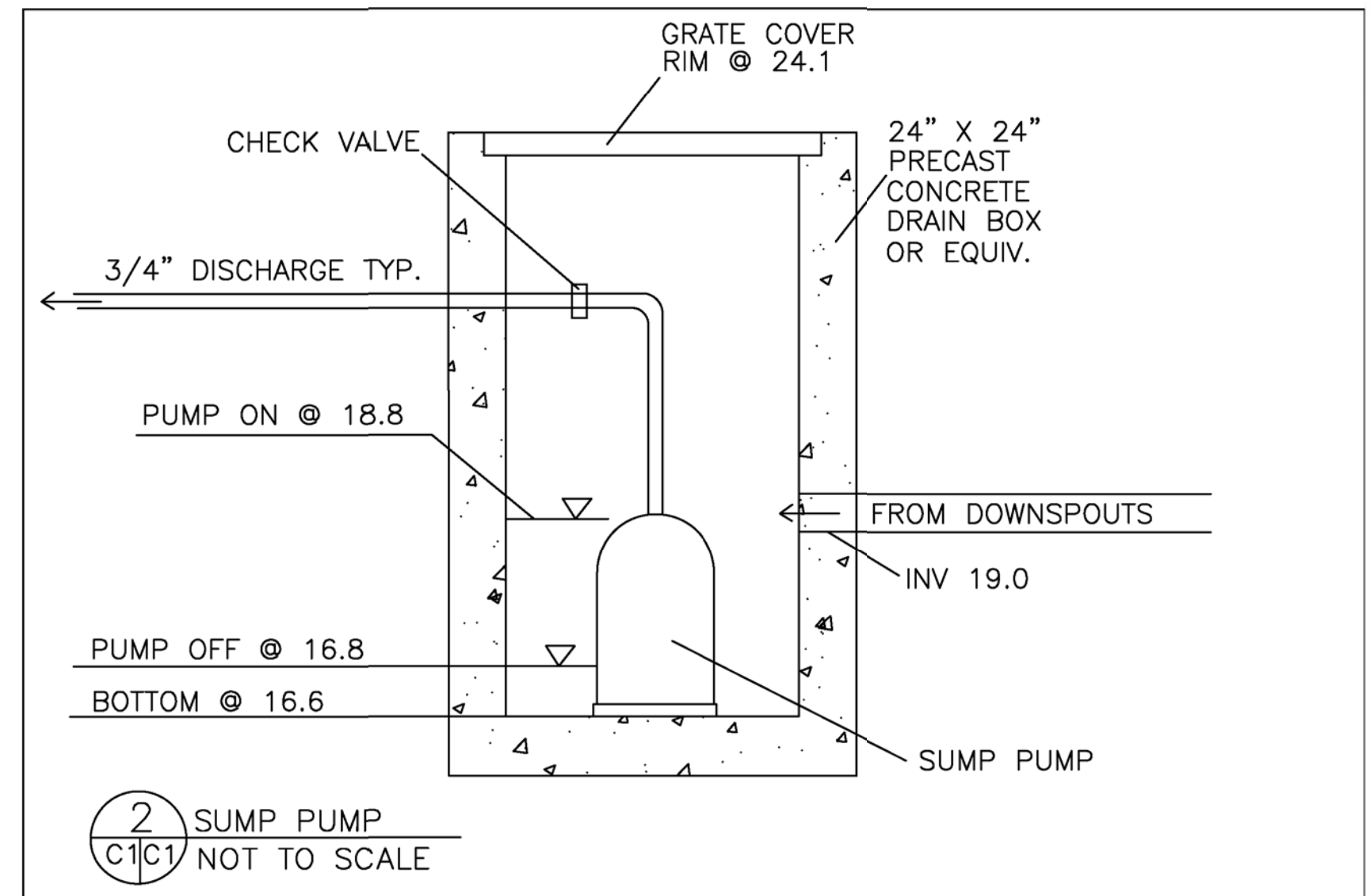

2 SUMP PUMP
 C1/C1 NOT TO SCALE

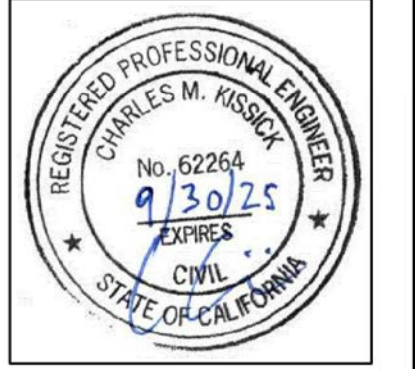

Sigma Prime Geosciences, Inc.
 SIGMA PRIME GEOSCIENCES, INC.
 322 FLORENCE AVENUE
 PRINCETON, CA 94119
 (650) 728-3590
 FAX 728-3593

DATE: 1-30-24
 DRAWN BY: CMK
 CHECKED BY: AZG
 REV. DATE: _____
 REV. DATE: _____
 REV. DATE: _____

GRADING AND DRAINAGE PLAN
 FRENCH PROPERTY
 166 CALIFORNIA AVENUE
 PRINCETON
 APN 047-031-440

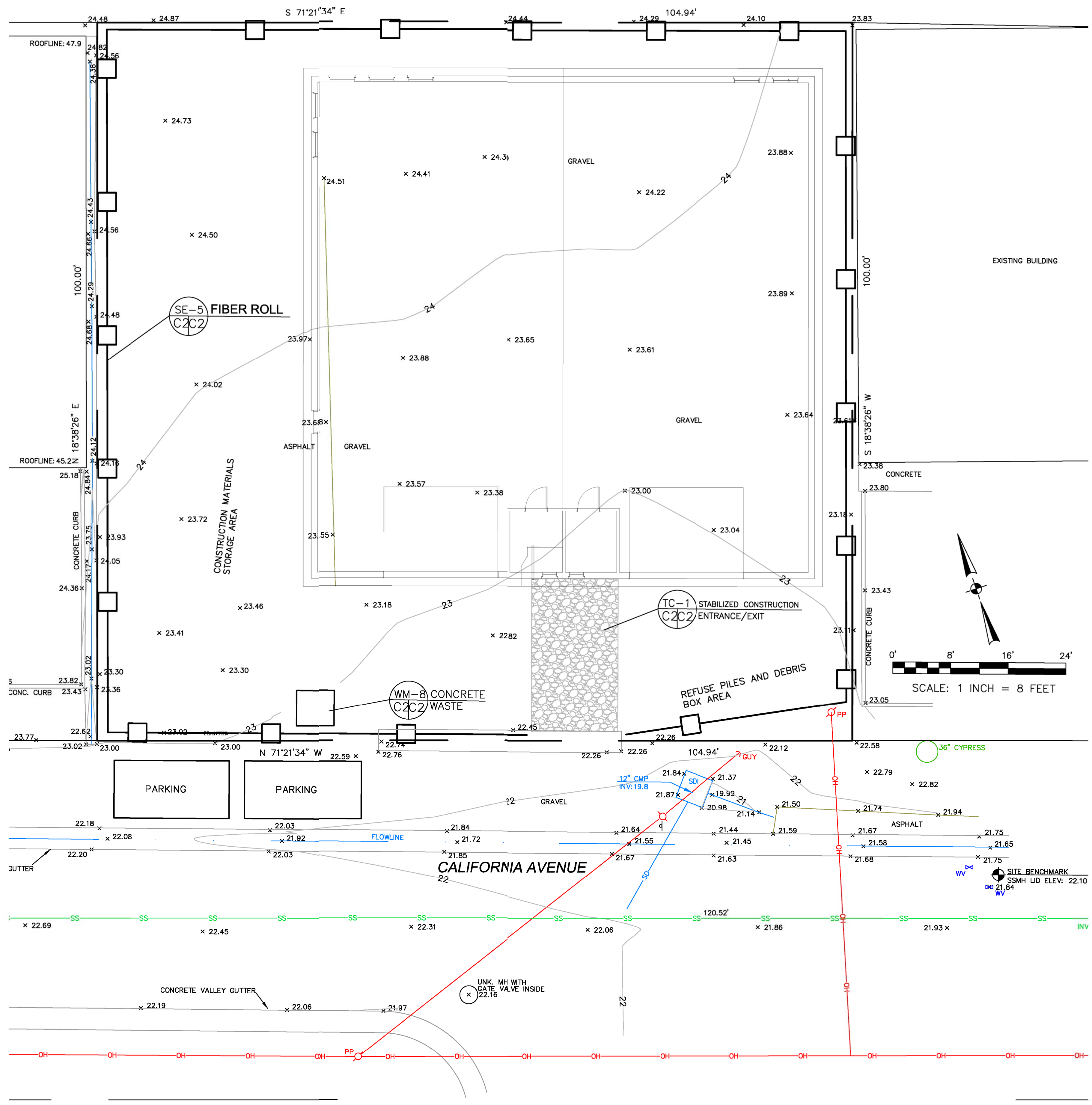

EROSION CONTROL NOTES

- FIBER ROLL
INSTALL AT LOCATIONS SHOWN.
AFIX AS SHOWN IN DETAIL SE-5
1. GRADING MAY TAKE PLACE DURING WET WEATHER AFTER OCTOBER 1 PROVIDED THE FOLLOWING PROVISIONS ARE FOLLOWED.
 2. NO GRADING SHALL TAKE PLACE DURING RAINY WEATHER OR FOR A PERIOD OF AT LEAST 24 HOURS FOLLOWING RAIN.
 3. ALL EXPOSED SOIL SHALL BE TEMPORARILY PROTECTED FROM EROSION WITH JUTE NETTING.
 4. ALL STOCKPILED SOIL SHALL BE COVERED AT ALL TIMES AND REMOVED FROM SITE AS SOON AS POSSIBLE, IF SCHEDULED FOR OFF-HAUL.
 5. ALL EXPOSED SURFACES SHALL BE PERMANENTLY PROTECTED FROM EROSION WITH SEEDING AND/OR LANDSCAPING. SEED MIX SHALL BE 75 LB PER ACRE ANNUAL RYGRASS OR APPROVED SUBSTITUTE. SEED SHALL BE COVERED WITH STRAW MULCH AT A RATE OF 2 TONS/ACRE.
 6. ROCKED CONSTRUCTION ENTRANCE SHALL BE 50 FEET LONG BY 15 FEET WIDE AND CONFORM TO THE FOLLOWING:
 - A. THE MATERIAL FOR THE PAD SHALL BE 3 TO 6 INCH STONE.
 - B. PAD SHALL BE NOT LESS THAN 12" THICK.
 - C. THE ENTRANCE SHALL BE MAINTAINED IN A CONDITION THAT WILL PREVENT TRACKING OR FLOWING OF SEDIMENT ONTO PUBLIC RIGHT-OF-WAY. THIS MAY REQUIRE PERIODIC TOP DRESSING WITH ADDITIONAL STONE AS CONDITIONS DEMAND, AND REPAIR AND/OR CLEANOUT OF ANY MEASURES USED TO TRAP SEDIMENT. ALL SEDIMENT SPILLED, DROPPED, WASHED, OR TRACKED ONTO PUBLIC RIGHT-OF-WAY SHALL BE REMOVED IMMEDIATELY.
 - D. WHEN NECESSARY, WHEELS SHALL BE CLEANED TO REMOVE SEDIMENT PRIOR TO ENTRANCE ONTO PUBLIC RIGHT-OF-WAY. WHEN WASHING IS REQUIRED, IT SHALL BE DONE ON AN AREA THAT DRAINS TO THE CONCRETE WASHOUT AREA.
 7. CONCRETE WASHOUT AREA SHALL BE SURROUNDED BY A SINGLE LAYER OF SAND BAGS TO CONTAIN FLUIDS. CHANNEL INTO AREA SHALL BE CLEARED TO ALLOW TIRE DEBRIS (SEE NOTE 6.D. ABOVE)

GENERAL EROSION AND SEDIMENT CONTROL NOTES

- There will be no stockpiling of soil. All excavated soil will be hauled off-site as it is excavated.
- Perform clearing and earth-moving activities only during dry weather. Measures to ensure adequate erosion and sediment control shall be installed prior to earth-moving activities and construction.
- Erosion control materials to be on-site during off-season.
- Measures to ensure adequate erosion and sediment control are required year-round. Stabilize all denuded areas and maintain erosion control measures continuously between October 1 and April 30.
- Store, handle, and dispose of construction materials and wastes properly, so as to prevent their contact with stormwater.
- Control and prevent the discharge of all potential pollutants, including pavement cutting wastes, paints, concrete, petroleum products, chemicals, wash water or sediments, and non-stormwater discharges to storm drains and watercourses.
- Avoid cleaning, fueling, or maintaining vehicles on-site, except in a designated area where wash water is contained and treated.
- Limit and time applications of pesticides and fertilizers to prevent polluted runoff.
- Limit construction access routes to stabilized, designated access points
- Avoid tracking dirt or other materials off-site; clean off-site paved areas and sidewalks using dry sweeping methods.
- Train and provide instruction to all employees and subcontractors regarding the Watershed Protection Maintenance Standards and construction Best Management Practices.
- Placement of erosion materials is required on weekends and during rain events.
- The areas delineated on the plans for parking, grubbing, storage etc., shall not be enlarged or "run over."
- Dust control is required year-round.
- Erosion control materials shall be stored on-site

CONCRETE WASTE MANAGEMENT WM-8

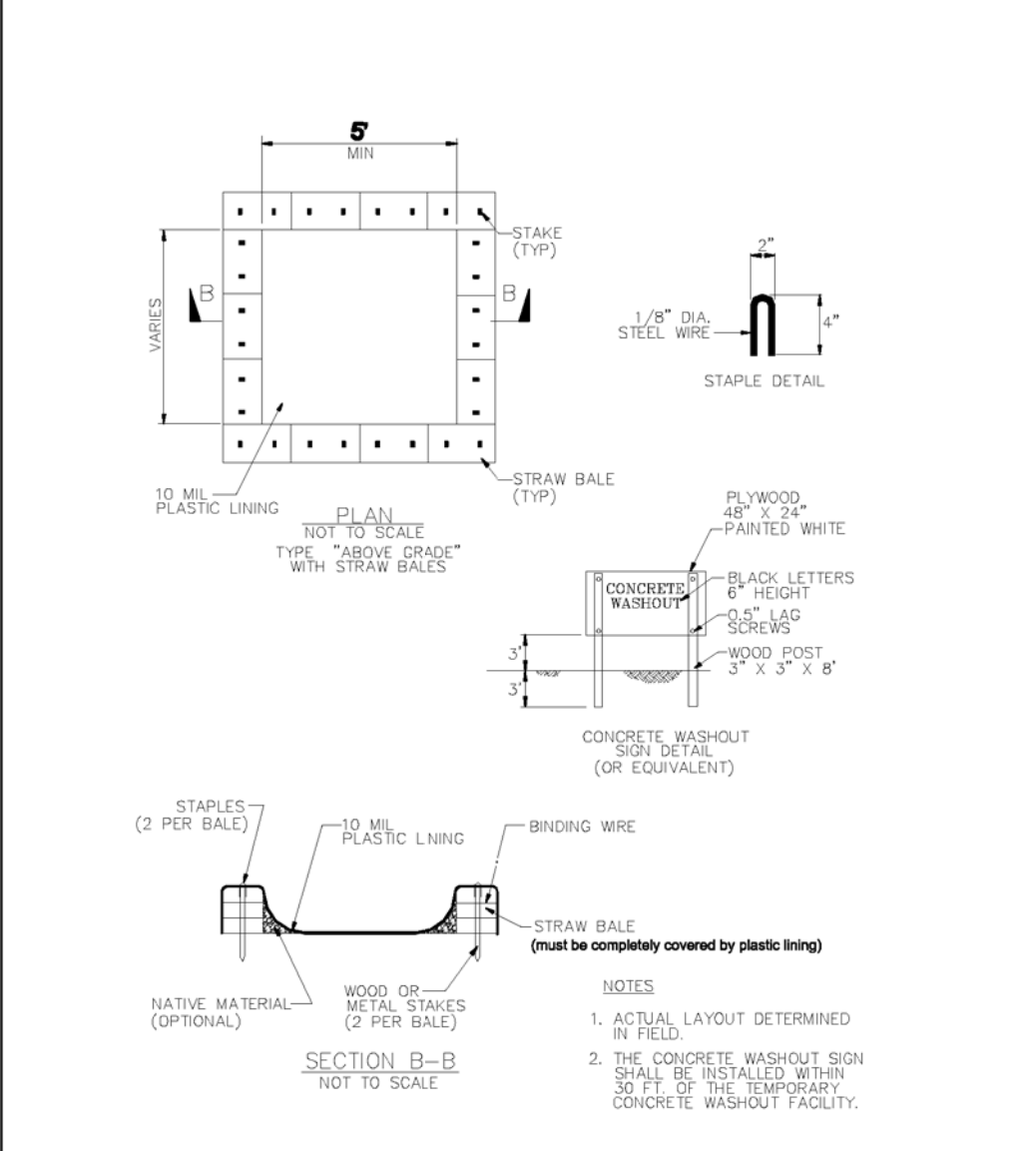

EROSION CONTROL POINT OF CONTACT

THIS PERSON WILL BE RESPONSIBLE FOR EROSION CONTROL AT THE SITE AND WILL BE THE COUNTY'S MAIN POINT OF CONTACT IF CORRECTIONS ARE REQUIRED.

NAME: BRYAN FALVEY

TITLE/QUALIFICATION: CONTRACTOR

PHONE: 650-302-4358

PHONE:

E-MAIL: FALCOHM81@GMAIL.COM

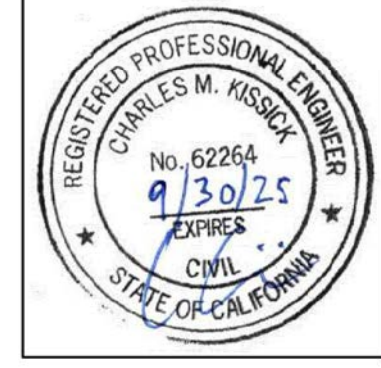

FIBER ROLLS SE-5

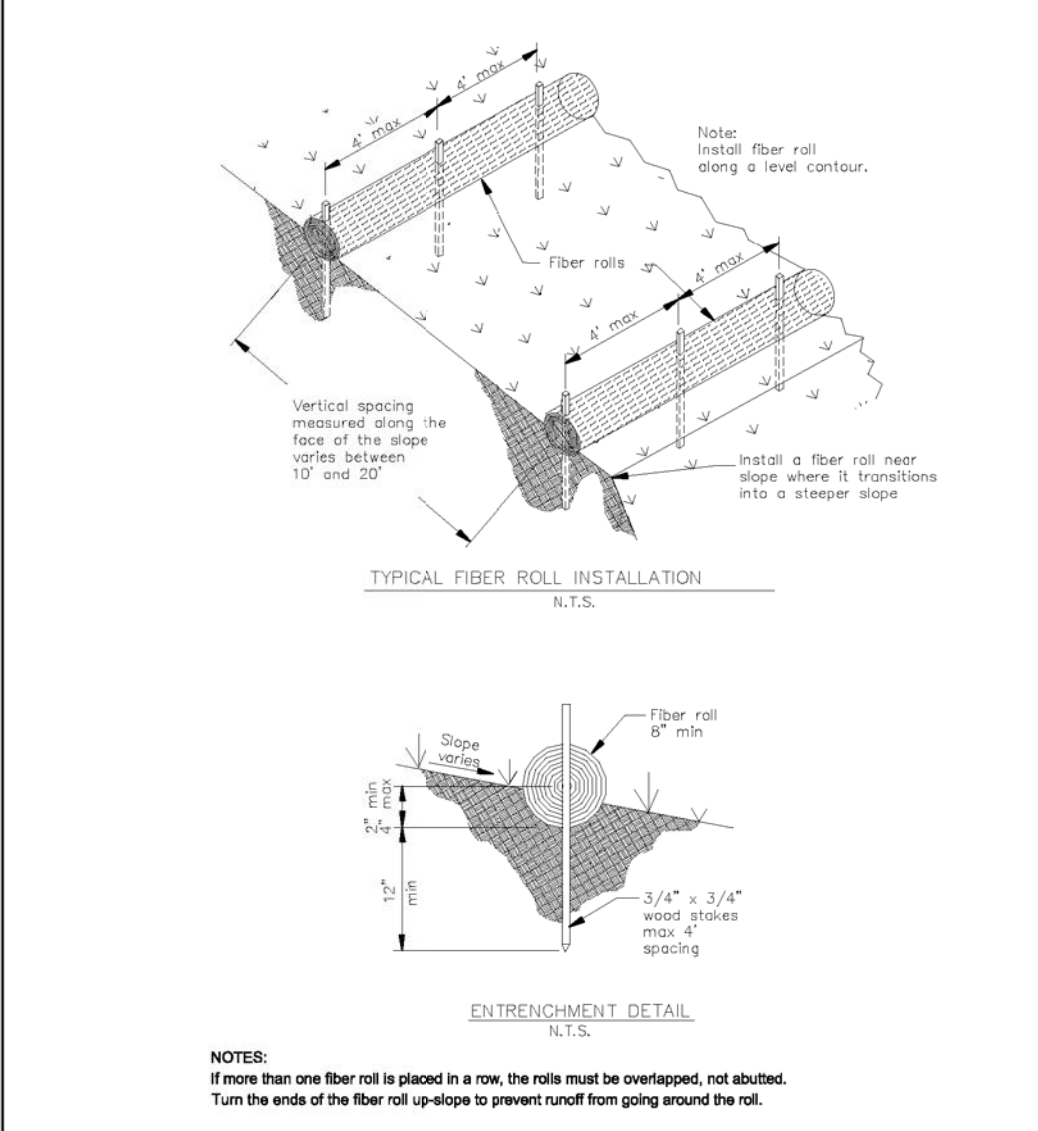

STABILIZED CONSTRUCTION ENTRANCE/EXIT TC-1

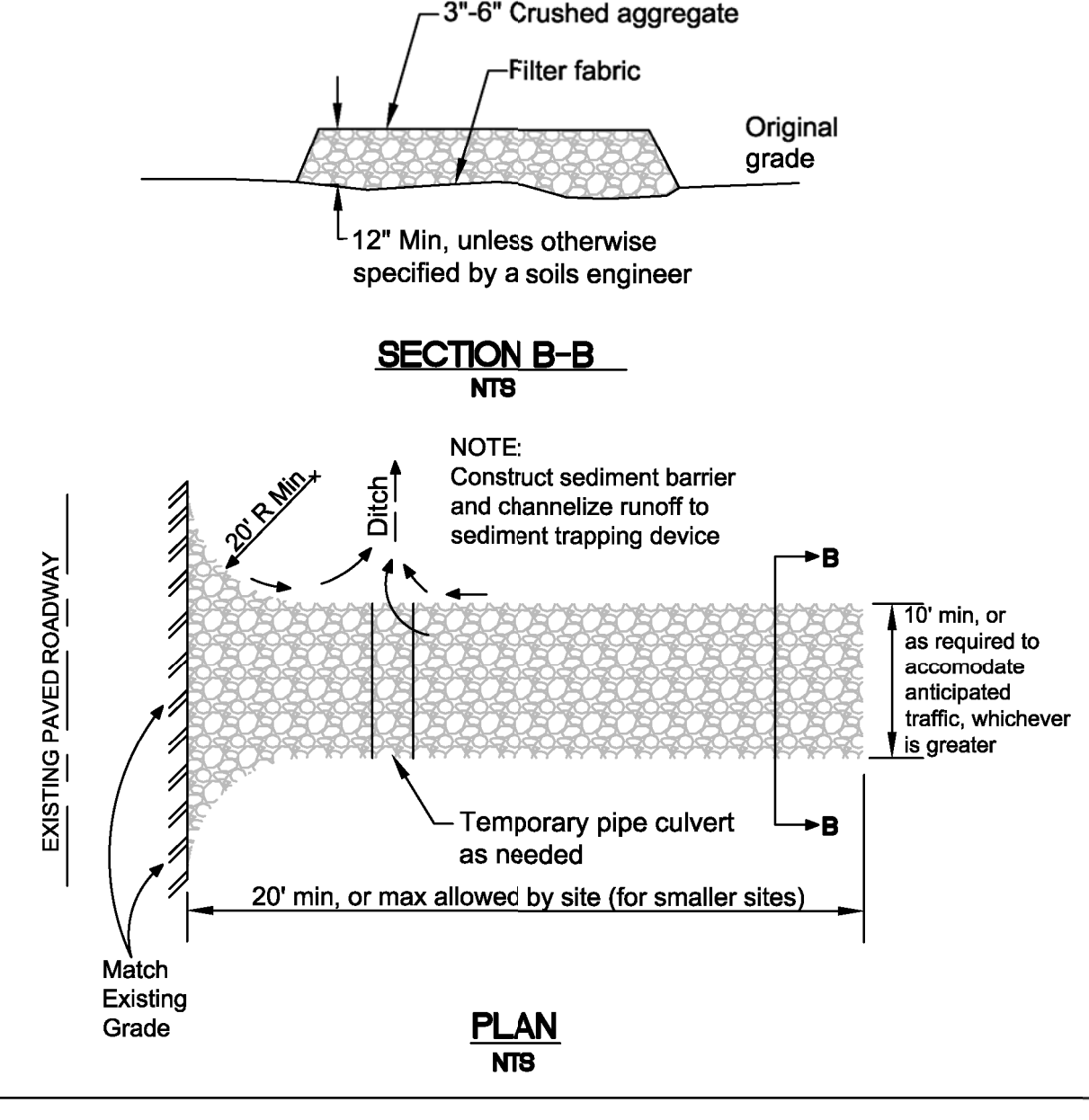

DATE: 1-30-24
 DRAWN BY: CNK
 CHECKED BY: AZG
 REV. DATE: 1-30-24
 REV. DATE: 1-30-24
 REV. DATE:

EROSION AND SEDIMENT CONTROL PLAN

FRENCH PROPRIETY
 166 CALIFORNIA AVENUE
 PRINCETON
 APN 047-031-440

SHEET
C-2

Window Schedule

Mark	Type	Width	Height	Sill Height	Tempered Glass	Comments
3	FIXED	3' - 6"	5' - 0"	15' - 0"		
4	FIXED	3' - 6"	5' - 0"	15' - 0"		
5	FIXED	3' - 6"	5' - 0"	15' - 0"		
6	FIXED	3' - 6"	5' - 0"	15' - 0"		
7	FIXED	3' - 6"	5' - 0"	15' - 0"		
8	FIXED	3' - 6"	5' - 0"	15' - 0"		
9	FIXED	3' - 6"	5' - 0"	15' - 0"		
10	FIXED	2' - 0"	2' - 0"	5' - 0"		
11	FIXED	2' - 0"	2' - 0"	5' - 0"		

Door Schedule

Mark	Type	Width	Height	Comments
2	Solid Core Door	3' - 0"	6' - 8"	
3	Solid Core Door	3' - 0"	6' - 8"	
4	Overhead Garage Door	16' - 0"	12' - 0"	
5	Overhead Garage Door	16' - 0"	12' - 0"	
6	Double Glass Entry Door	6' - 0"	7' - 0"	

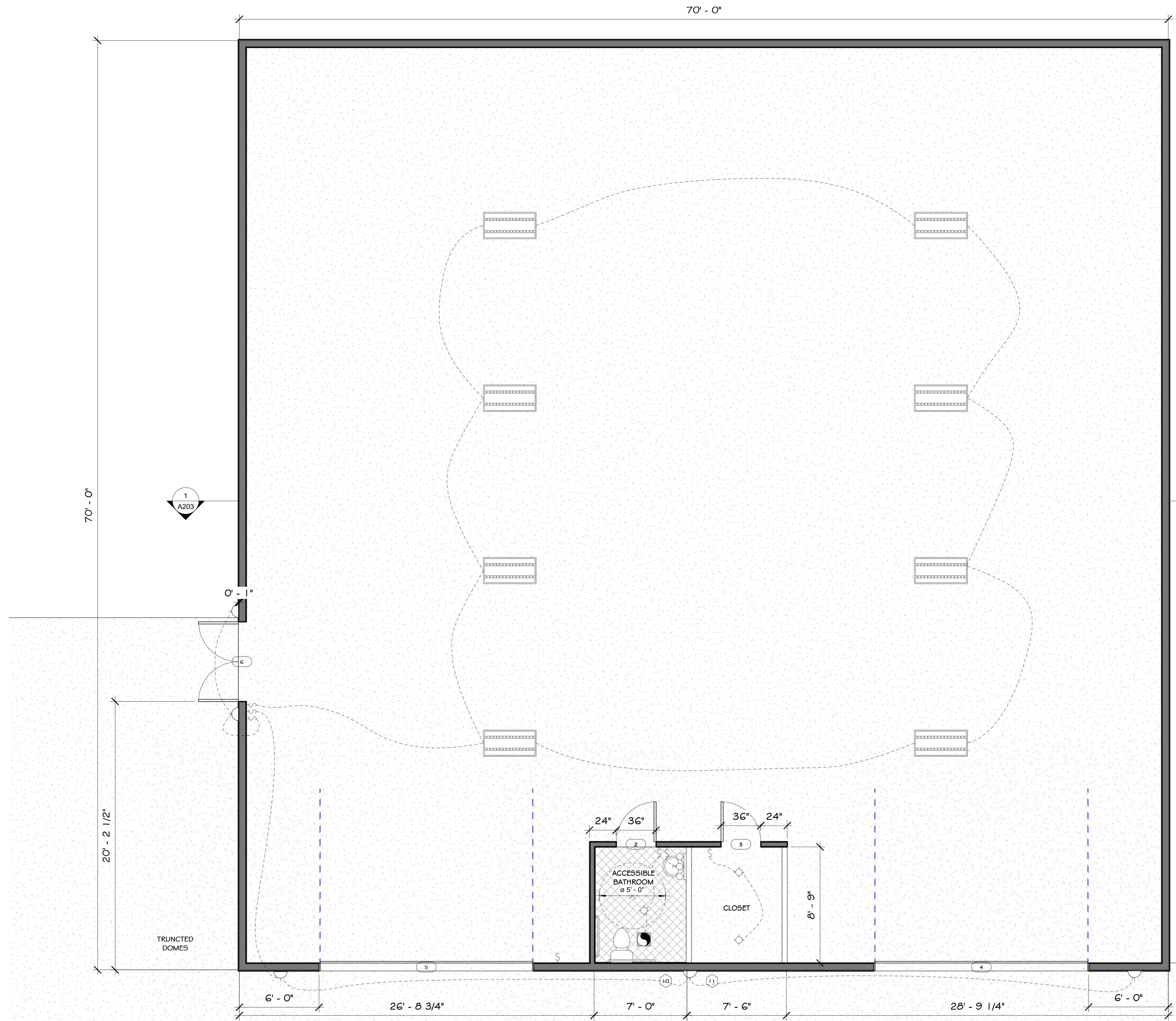

REVISIONS



Edward C. Love
Architect
720 MILL STREET
HALF MOON BAY, CA 94019
(650) 728-7615
edwardclovearch@gmail.com

French Storage
Art & Thelma French
166 California Ave HMB, CA

Floor Plan



DATE: 9/3/2024
SCALE: 1/4" = 1'-0"
DRAWN: Author
JOB: French Storage
SHEET:

A102

OF SHEETS

- SWITCH - SINGLE
- SWITCH - DIMMER
- SWITCH - DIMMER, THREE-WAY
- SWITCH - MOTION
- RECESSED LIGHT
- 4FT. BOX LIGHT DOUBLE
- EXTERIOR LIGHT
- VANITY FIXTURE (STYLE TBD)
- FAN

Legend - Lighting

1/4" = 1'-0"

S:\Client Projects 2024\French Storage\Revit\French Storage.rvt

S:\Client Projects 2024\French Storage\Revit\French Storage.rvt

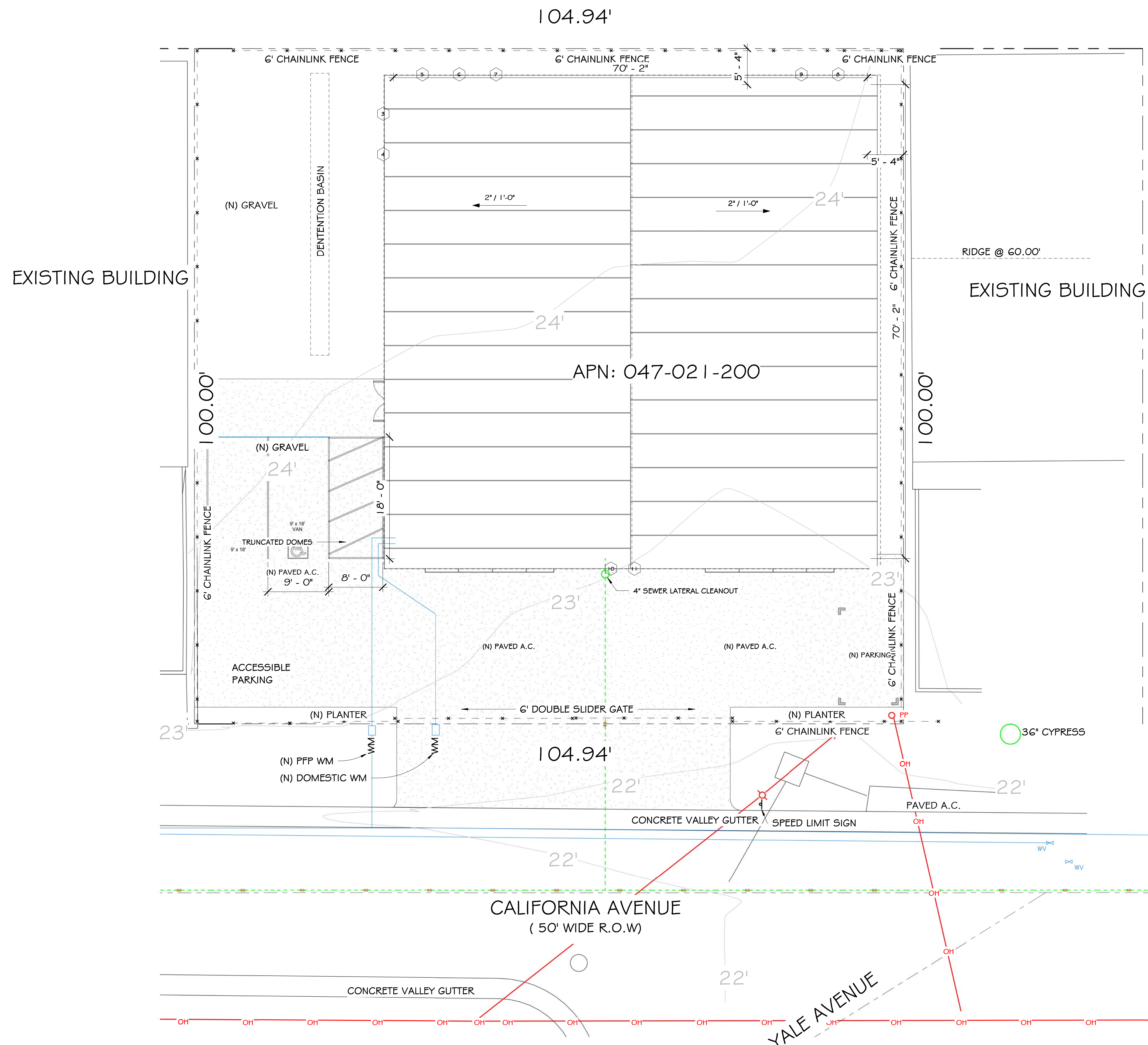

1 Roof Plan
1/8" = 1'-0"

SITE PLAN BASED ON SURVEY TAKEN SEPTEMBER 2023
BY BGT LAND SURVEYING

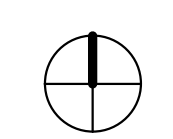

Project North

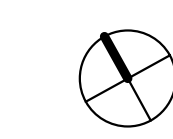

True North

REVISIONS



Edward C. Love
Architect
720 MILL STREET
HALF MOON BAY, CA 94019
(650) 728-7615
edwardclovearch@gmail.com

French Storage
Art & Thelma French
166 California Ave HMB, CA

Roof Plan

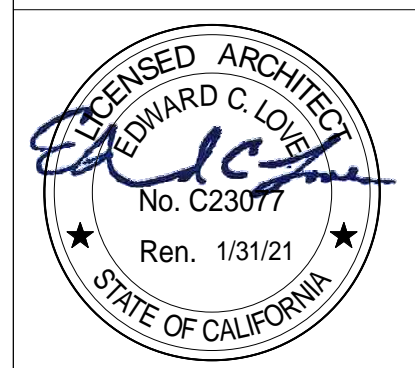

DATE: 9/3/2024
SCALE: 1/8" = 1'-0"
DRAWN: Author
JOB: French Storage
SHEET:

A103

OF SHEETS

ALL DRAWINGS, SPECIFICATIONS, AND COPIES THEREOF, PREPARED AND/OR SUPPLIED BY THE ARCHITECT, SHALL REMAIN HIS PROPERTY. THEY ARE TO BE USED ONLY WITH RESPECT TO THIS PROJECT AND ARE NOT TO BE USED ON ANY OTHER PROJECT. WITH THE EXCEPTION OF ONE CONTRACT SET FOR EACH PARTY TO THE CONTRACT, SUCH DOCUMENTS ARE TO BE RETURNED OR SUITABLY ACCOUNTED FOR UPON REQUEST OF THE ARCHITECT AT THE COMPLETION OF THE WORK. SUBMISSION OR DISTRIBUTION TO MEET OFFICIAL REGULATORY REQUIREMENTS OR FOR OTHER PURPOSES IN CONNECTION WITH THE PROJECT IS NOT TO BE CONSTRUED AS PUBLICATION IN THE DEROGATION OF THE ARCHITECT'S COMMON LAW COPYRIGHT OR OTHER RESERVED RIGHTS.

PAC-CLAD STANDING SEAM
METAL ROOF - MUSKET GRAY

METAL FASCIA BOARD WITH
GUTTER PAINTED NIGHT
HORIZON - BJM

METAL SIDING PAINTED -
OVERCOAT CC-544 BJM

ROOF AWNING PAINTED -
WILLOW CC-542 BJM

DARK SKY COMPLIANT
EXT. LIGHT

29' - 11 1/4"
FROM GRADE

① East
1/4" = 1'-0"

1
A203

PAC-CLAD STANDING SEAM METAL
ROOF - MUSKET GRAY

METAL FASCIA BOARD WITH GUTTER -
PAINTED NIGHT HORIZON BMJ

METAL SIDING PAINTED CC-544 BJM

ROOF AWNING

DARK SKY COMPLIANT EXT. LIGHT

ENTRY DOOR - NIGHT HORIZON BMJ

CLEAR STORY
WINDOWS

29' - 11 1/4"
FROM GRADE

② West
1/4" = 1'-0"

REVISIONS



EDWARD C. LOVE, ARCHITECT

Edward C. Love
Architect
720 MILL STREET
HALF MOON BAY, CA 94019
(650) 728-7615
edwardclovearch@gmail.com

French Storage
Art & Thelma French
166 California Ave HMB, CA

Elevation North &
South

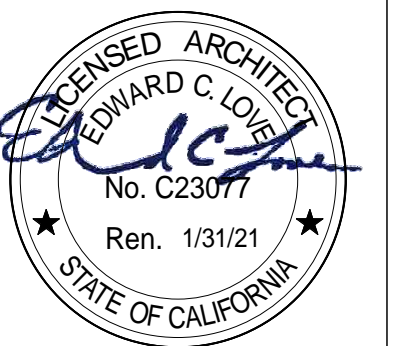

DATE: 9/3/2024

SCALE: 1/4" = 1'-0"

DRAWN: Author

JOB: French Storage

SHEET:

A201

OF SHEETS

METAL FASCIA BOARD WITH
5" GUTTER PAINTED NIGHT
HORIZON - BJM

PAC-CLAD STANDING SEAM METAL
ROOF - MUSKET GRAY



CLEAR STORY
WINDOWS

DARK SKY COMPLIANT EXT.
LIGHTING

① North
1/4" = 1'-0"



FASCIA PAINTED - NIGHT HORIZON
BJM

DARK SKY COMPLIANT EXT. LIGHT
16' GARAGE DOOR - PAINTED -
CHELSEA GRAY - HC-168

② South
1/4" = 1'-0"

REVISIONS



EDWARD C. LOVE, ARCHITECT

Edward C. Love
Architect
720 MILL STREET
HALF MOON BAY, CA 94019
(650) 728-7615
edwardclovearch@gmail.com

French Storage
Art & Thelma French
166 California Ave HMB, CA

Elevations East & West



DATE: 9/3/2024
SCALE: 1/4" = 1'-0"
DRAWN: Author
JOB: French Storage
SHEET:
A202
OF SHEETS

S:\Client Projects 2024\French Storage\Revit\French Storage.rvt

S:\Client Projects 2024\French Storage\Revit\French Storage.rvt

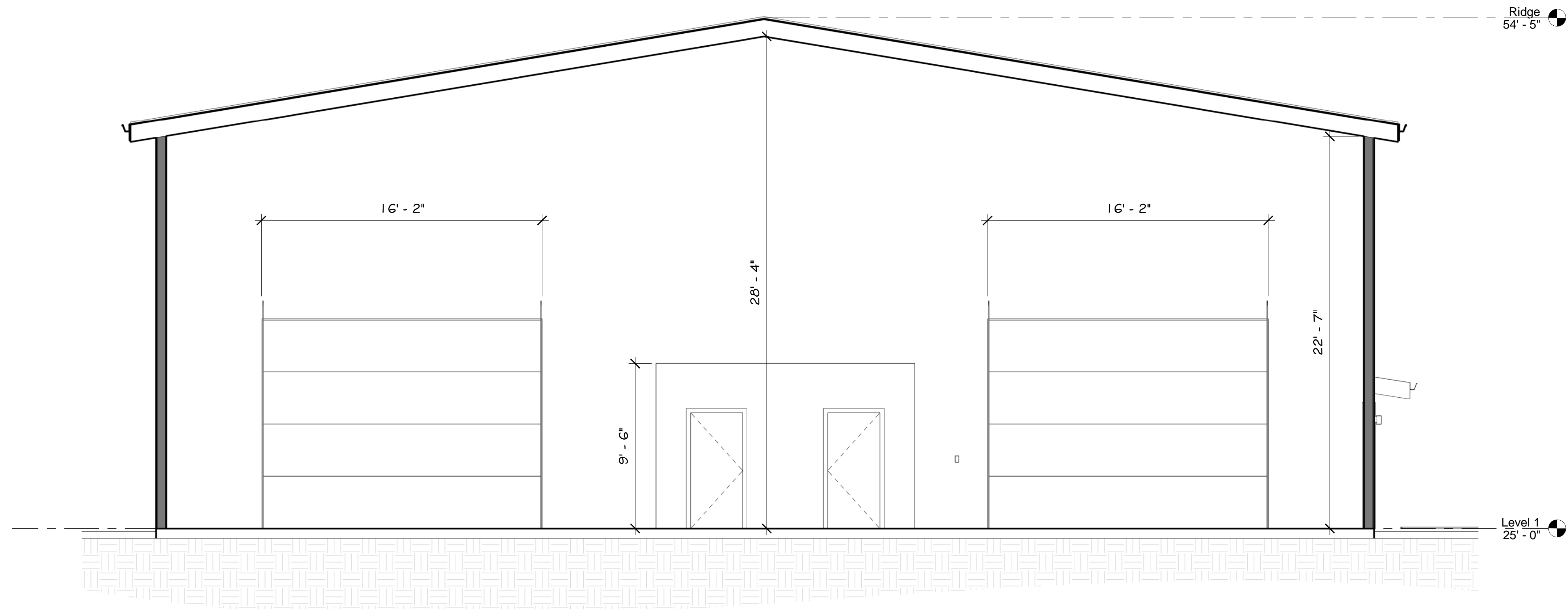

① Section 1
1/4" = 1'-0"

REVISIONS



EDWARD C. LOVE, ARCHITECT

Edward C. Love
Architect
720 MILL STREET
HALF MOON BAY, CA 94019
(650) 728-7615
edwardclovearch@gmail.com

French Storage
Art & Thelma French
166 California Ave HMB, CA

Section

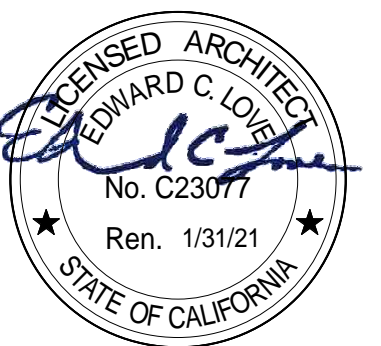

DATE: 9/3/2024
SCALE: 1/4" = 1'-0"
DRAWN: Author
JOB: French Storage

SHEET:
A203

OF SHEETS



Product Overview

The outdoor LED wall lantern is uniquely designed with a contemporary feel. Its durable aluminum construction with hand painted black finish and frosted glass gives a sophisticated look.

This uniquely designed fixture is the choice of discriminating yet value conscious homeowners who want to enrich their home.

Darksky certified
 Light color is 3000K (bright white)
 360 Lumens
 80 CRI and uses only 5.5-Watt

Specifications

Dimensions

Product Depth (in.)	5.91	Product Height (in.)	8.01
Product Length (in.)	8.01	Product Width (in.)	4.49

Details

Actual Color Temperature (K)	3000	Color Rendering Index	80
Color Temperature	Bright White		

Exterior Lighting Product Type	Cylinder Lights	Fixture Color/Finish	Black
Fixture Material	Aluminum	Glass/Lens Type	Frosted

Light Bulb Type Included	Integrated LED	Light Output (lumens)	360
Maximum Wattage (watts)	0	Number of Bulbs Required	0
Watt Equivalence	60		

Outdoor Lighting Features: Dark Sky, Weather Resistant, Weather Resistant

Power Type: Hardwired
 Product Weight (lb.): 2.29lb

Style: Modern

REVISIONS



EDWARD C. LOVE, ARCHITECT

Edward C. Love
 Architect
 720 MILL STREET
 HALF MOON BAY, CA 94019
 (650) 728-7615
 edwardclovearch@gmail.com

French Storage
 Art & Thelma French
 166 California Ave HMB, CA

Spec Sheets



DATE: 9/3/2024

SCALE:

DRAWN: Author

JOB: French Storage

SHEET:

A204

OF SHEETS